



Trimble Access General Survey

Version 2016.00
Revision A
April 2016

Legal information

Trimble Navigation Limited

www.trimble.com

Copyright and Trademarks

© 2009–2016, Trimble Navigation Limited. All rights reserved.

Trimble, the Globe and Triangle logo, Autolock, CenterPoint, Geodimeter, GPS Pathfinder, GPS Total Station, OmniSTAR, Spectra Precision, Terramodel, Tracklight, TSC2, and xFill are trademarks of Trimble Navigation Limited, registered in the United States and in other countries.

Access, FastStatic, FineLock, GX, RoadLink, TerraFlex, Trimble Business Center, Trimble Geomatics Office, Trimble Link, Trimble RTX Trimble Survey Controller, Trimble Total Control, TRIMMARK, VISION, VRS, VRS Now, VX, and Zephyr are trademarks of Trimble Navigation Limited.

RealWorks is a registered trademark of Mensi SA.

Microsoft, ActiveSync, Excel, Internet Explorer, Windows, Windows Mobile, Windows Vista and Word are either registered trademarks or trademarks of Microsoft Corporation in the United States and/or other countries.

The Bluetooth word mark and logos are owned by the Bluetooth SIG, Inc. and any use of such marks by Trimble Navigation Limited is under license.

Wi-Fi is a registered trademark of the Wi-Fi Alliance.

All other trademarks are the property of their respective owners.

This software is based in part on the work of the Independent JPEG Group, derived from the RSA Data Security, Inc, MD5 Message-Digest Algorithm.

Contents

1 Introduction	11
Introduction	11
Interacting with other applications	13
2 General Operations	14
The General Survey screen	14
Status bar	14
Status line	18
General Survey buttons	19
Shortcuts	21
Controllers	24
Trimble TSC3 controller	25
Trimble TSC2 controller	29
Trimble tablet	32
Trimble CU controller	35
Trimble Geo7X handheld	40
Trimble GeoXR controller	44
Trimble Slate controller	47
Trimble S3 controller	49
Trimble M3 total station	51
Controller keyboard functions	53
Printing from a P4T mobile Bluetooth printer	58
Entering quadrant bearings	59
Calculator	59
Troubleshooting	59
Jobs menu	64
Job repair wizard	65
3 Job Operations	66
Managing jobs	66
File management	68
Reviewing and editing job properties	71
Reviewing data stored in the job	71
Managing data in the Point manager	76
Coordinate view	84
Station and offset	85
QC graph	85
Storing points	86
Viewing the map	89
AccessVision	94
Selecting data to display in the map	94
Linking files to the current job	96

Adding data files as map layers	97
Using the Map for common tasks	102
Surfaces and volumes	107
Selecting points	108
Units	110
Time/Date	112
Cogo settings	113
CAD toolbar	119
Offset line	123
Compute intersection	123
Using a feature library	124
Additional settings	128
Media files	130
Drawing on an image	133
Using a camera to capture an image	134
Annotating a snapshot	138
Linking media files	139
Copying between jobs	144
Importing and exporting fixed and custom format files	145
Sending and receiving ASCII data between external devices	145
Import and export fixed format files	150
Export custom format files	153
Import custom format files	156
4 Key In	158
Key in menu	158
Keying in points	158
Keying in lines	159
Keying in arcs	160
Keying in alignments	164
Keying in notes	166
5 Cogo	167
Cogo menu	167
Compute inverse	168
Compute point	168
Area calculations	175
Compute volume	176
Compute distance	178
Compute azimuth	179
Compute average	182
Arc solutions	184
Triangle solutions	189
Subdivide a line	190
Subdivide an arc	192

Transformations	194
Traverse	199
Taped distances	201
Calculator	202
Pop-up menu controls	204
6 Survey – General	205
Measuring and staking out	205
Getting connected	206
Measure codes	207
7 Conventional Survey – Setup	213
Conventional survey – Getting started	213
Configuring conventional survey styles	213
Conventional instrument configuration	214
Conventional instrument type	216
Configure topo point settings	222
Preparing for a robotic survey	222
Station setups – Overview	224
Station setup	226
Station setup plus	230
Measuring rounds in station setup plus or resection	233
Station elevation	236
Resection	237
Refine	241
Station setup plus, resection, and rounds options	242
Conventional instrument corrections	244
Target details	246
Prism constant	249
GDM CU programs	249
Advanced Geodetic support	252
Start the survey	253
End the survey	253
8 Conventional Survey – Measure	254
Measuring points in a conventional survey	254
Measuring topo points in a conventional survey	255
Measuring a point in two faces	257
Continuous topo – conventional	259
Angles and distance	261
Averaged observations	261
Angle offset, H.Angle offset, and V.Angle offset	262
Distance offset	263
Measure points on a plane	264
Measure 3D axes	265

Dual-prism offset	267
Circular object	268
Measure rounds	269
Remote object	273
Scanning	274
Surface scan	279
Panorama	282
Check point	283
Fast fix	284
9 Survey – Calibration	285
Calibration	285
Configuring the survey style for a site calibration	286
Manual calibration	288
Automatic calibration	289
10 GNSS Survey – Setup	291
GNSS survey – Getting started	291
Configuring GNSS survey styles	291
Rover and base options	293
Data link options	300
Measurement method options	300
PP initialization times	303
Setting up the equipment for a rover receiver	305
Measuring antenna heights	305
Antenna.ini file	310
Base receiver setup	310
Operating several base stations on one radio frequency	316
Wide-area RTK surveys	318
RTK on demand	319
RTX correction service	320
Satellite-based augmentation system (SBAS)	323
OmniSTAR differential correction service	324
Starting the rover survey	327
Initialization	329
Starting a real-time survey using a dial-in connection	333
Starting a real-time survey using a mobile Internet connection	333
Redialing the base station	334
Ending the rover survey	335
11 GNSS Survey – Measure	336
Measuring points in a GNSS survey	336
Topo point	338
Compensated point	340
Using a GNSS receiver with a built-in tilt sensor and magnetometer	342

Observed control point	345
Rapid point	346
FastStatic point	347
Continuous topo – GNSS	349
Fast fix	351
Check point	351
Measuring points with a laser rangefinder	351
12 Survey – Integrated	353
Integrated surveys	353
IS rover survey rod	356
13 Survey – Imaging	358
Trimble V10 imaging rover	358
Equipment setup	358
Height measurement methods	361
Capturing panoramas when measuring a point in a conventional survey	366
Capturing panoramas when measuring a point in a GNSS survey	367
HDR imaging	368
Attaching a panorama to a point	369
V10 photo station coverage areas	369
V10 camera calibration check	370
V10 eBubble options	371
V10 magnetometer calibration	372
14 Survey – Stakeout	374
Stakeout – Overview	374
Configuring the stakeout display mode	375
Using the graphical display during stakeout	377
Stakeout options	379
As-staked point details	379
Staking out points	383
Staking out lines	390
Staking out arcs	393
Staking out alignments	397
Staking out a station on an alignment	402
Staking out the side slope from an alignment	403
Staking out a station at a skew offset from an alignment	405
Hinge derivation methods	407
Cross section view	407
Specifying construction offsets	407
Specifying a side slope	409
Catch point	410
Catch point staked deltas	411
Digital terrain models (DTMs)	412

15	Survey Settings	414
	Settings menu	414
	Survey styles	415
	Survey types	416
	Configuring the survey style to use a laser rangefinder	416
	Echo sounder instruments	419
	NMEA outputs	422
	Duplicate point tolerance	423
	Feature libraries	426
	Configuring a radio data link	431
	Cellular modem – Overview	434
	Configuring an Internet data link	435
	Configuring a dial-in data link	435
	GNSS contacts	436
	Creating a GNSS contact for a dial-in data link	437
	Creating a GNSS contact for an Internet data link	439
	Connecting to the Internet	443
	Bluetooth	448
	Compass	454
	Transferring files between controllers	455
	Language	455
	Sound events	456
	Templates	456
	Auxiliary GPS	457
16	Conventional Survey Instruments	458
	Conventional Instrument menu	458
	Navigate to point	459
	Station setup details	460
	Electronic level	460
	EDM settings	461
	Laser pointer	463
	Turn to	465
	Joystick	465
	Tracklight	467
	Instrument settings	468
	Instrument adjustment	471
	Survey Basic	473
	Instrument functions	476
	Target tracking	477
	Target controls	482
	Autolock, FineLock, and Long Range FineLock technology	482
	GPS search	487
	Interrupted target measurement	491

Video	492
Camera options	495
Data output	497
Radio settings	500
AT360 eBubble options	502
Battery status	503
17 GNSS Survey Instruments	504
Instrument menu	504
GNSS Instrument menu	504
GNSS instrument functions	505
Satellites	507
Receiver files	509
Position	509
Receiver status	510
Receiver settings	511
R10 eBubble options	512
Magnetometer calibration	514
Navigate to point	515
RTK network status	516
Battery status	516
18 Coordinate System	517
Coordinate system	517
Customizing the coordinate system database	518
Scale factor only	520
Projection	520
Ground coordinate system	520
Project height	521
No projection / no datum	521
Broadcast RTCM	522
SnakeGrid	523
Horizontal adjustment	524
Vertical adjustment	524
Coordinate systems	524
Trimble geoid models – WGS-84 versus local ellipsoid-based geoid models	534
Options softkey	535
Projection grids	536
Shift grids	537
19 Database Search Rules	538
Dynamic database	538
Search rules	539
Exceptions to the search rules	541
Linked files and their search rules	542

Finding the best point in the database	542
Duplicate points and overwriting	542
Assigning control class to a point	544
20 Calculations performed by the General Survey software	545
Transformations applied to GNSS positions	545
Ellipsoid calculations	551
Conventional instrument calculations	552
Standard errors recorded with conventional observations	558
Area calculations	558
Glossary	560

Introduction

Introduction

The General Survey software is a general surveying application for common field survey tasks for optical and GNSS sensors.

For help getting started with the General Survey software, see:

[The General Survey screen](#)

[Controllers](#)

[Troubleshooting](#)

General Survey software menus

From the Trimble Access menu tap General Survey to:

- Manage your [jobs](#)
- [Key in data](#)
- Carry out [COGO](#) functions
- [Measure](#) points
- [Stakeout](#) points, lines, arcs, alignments and DTMs
- Manage your [instruments](#)

Jobs menu

Use this menu to view and manage jobs, and transfer data between the office computer and external devices.

For more information, see [Job Operations](#).

Key in menu

Use the [Key in menu](#) to enter data into the General Survey software from the keypad.

Cogo menu

Use the [Cogo menu](#) to carry out Coordinate Geometry (Cogo) functions. You can use the menu options to calculate distances, azimuths, and point positions by various methods.

For some calculations, you must define a projection, or select a Scale factor-only coordinate system.

You can display ellipsoid, grid, or ground distances by changing the *Distances* field in the [Cogo settings](#) screen.

To perform Cogo calculations in a *No projection / No datum* coordinate system, set the *Distances* field to *Grid*. The General Survey software then performs standard Cartesian computations. If the grid distances you enter are distances on the ground, the new computed grid coordinates will be ground coordinates.

Note - *When the Distances field is set to Ground or Ellipsoid, the General Survey software attempts to perform calculations on the ellipsoid. Because there is no relationship established at this point, the system cannot compute coordinates.*

Measure menu

Use the *Measure* menu to measure points, codes, continuous topo points, or perform a site calibration.

For more information on:

- measuring using a conventional instrument, see [Measuring points in a conventional survey](#) .
- measuring using a GNSS instrument, see [Measuring points in a GNSS survey](#).

Stakeout menu

Use the [Stakeout menu](#) to stake points, lines, arcs, alignments (polylines) or digital terrain models (DTMs).

Instrument menu

This menu provides information about the instrument connected to the Trimble controller, and is used to configure the settings. Available options depend on the instrument that is connected.

For more information, see:

[Conventional Instrument menu](#)

[GNSS Instrument menu](#)

Further information

The contents of this file are installed on the controller with your application.

For information that extends or updates this Help, refer to the *Trimble Access Release Notes*. Go to <http://apps.trimbleaccess.com/help> to download the latest PDF file of the *Trimble Access Release Notes* or help file for each Trimble Access application.

Tip – For links between the Trimble Access application help PDF files to work, download PDF files to the same folder on your computer and do not change any of the file names.

To use this application with other applications, see [Interacting with other applications](#).

Interacting with other applications

You can run more than one application at a time and easily switch between them. For example, you can switch between functions in *Roads*, *Tunnels*, *Mines*, and *General Survey*.

To run more than one application at a time, use the Trimble button or Trimble icon in the top left corner of the screen to open the Trimble Access menu. From there, you can run the other application.

To switch between applications:

- Tap the Trimble button in the task bar to access the menu of available applications and services currently running, including the Trimble Access menu. Select the application or service to switch to.
- On the TSC2/TSC3 controller, a short press of the Trimble button accesses the menu of available applications and services currently running, including the Trimble Access menu. Select the application or service to switch to.
- On the Geo7X/GeoXR controller, tap the Trimble button to access the menu of available applications and services currently running, including the Trimble Access menu and the *Windows Start Menu*.
- On the Trimble Slate controller, tap the Trimble button to access the menu of available applications and services currently running, including the Trimble Access menu.
- Tap *Switch to* and then select the required function from the list. If the *Switch to* button is not on your current screen, press **CTRL W** to open the *Switch to* pop-up list.
- Press **CTRL TAB**. This is the keyboard shortcut to scroll through the current list of *Switch to* functions.
- Tap *Favourites* or press **CTRL A** to select a preconfigured favorite.
- On a controller that has application/function keys, configure the appropriate key for the function you want to run. This method opens an application even if that application is not running.

For more information, see [General Survey buttons](#).

General Operations

The General Survey screen

For an explanation of the buttons and icons on the General Survey screen, see:

[Status bar](#)

[Status line](#)



[General Survey buttons](#)









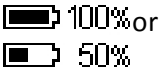
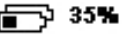









Status bar















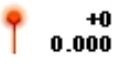

The status bar is on the top right side of the General Survey screen. The equipment that is connected to the controller determines which icons appear on the screen.

The following table describes the status bar icons.

Note - While the icons may look like specific models of a radio or a prism, these are generic icons that may not change if the radio model or prism type is changed.

Icon	What it shows
	Controller is connected to and drawing power from an external supply.
	Controller is connected to an external power supply and is recharging the internal battery.
	Power level is 100% or 50%. If this icon is on the top, it refers to the controller battery. If the icon is below the controller battery, it refers to the power level of an external device. For the Trimble M3 total station the upper battery icon refers to the state of the left hand battery and the lower battery icon to the state of the right hand battery.
	This icon is shown when multiple devices or one device with multiple batteries are connected to the controller. The percentage shown and the battery icon at the front of the "stack" indicate the power level of the connected battery that has the lowest power level. Tap the icon to view the <i>Battery status</i> screen which shows information about the power level of the batteries in all connected devices.

Icon	What it shows
	A Trimble R8s receiver is in use.
	A Trimble R10 receiver is in use.
	A Trimble V10 imaging rover is in use. When HDR imaging is turned on, HDR is shown to the right of the icon.
	A Trimble R7 receiver is in use.
	A Trimble R9s or NetR9 Geospatial receiver is in use.
	A Trimble R8 receiver is in use.
	A Trimble R2 receiver is in use.
	A 5800 receiver is in use.
	A 5700 GPS receiver is in use.
	An external antenna is in use. The antenna height is shown to the right of the icon.
	A Trimble M3 total station is in use.
	A Trimble VX Spatial Station or Trimble S8 total station is in use.
	A Trimble 5600 total station or a non-Trimble total station is in use.
	If a station setup is completed, the instrument height is shown to the right of the appropriate conventional instrument icon.
	A conventional instrument is receiving an EDM signal back from the prism.
	A conventional instrument is locked on to the target (prism).
	A conventional instrument is locked and measuring to the target (prism).
	A conventional instrument in Fast Standard (FSTD) mode averages the angles while a fast standard measurement is taken.





Icon	What it shows
	A conventional instrument in Standard (STD) mode averages the angles while a standard distance measurement is taken.
	A conventional instrument in Tracking (TRK) mode constantly measures distances and updates in the status line. (TRK is commonly used in stakeout and continuous topo.)
	The laser pointer is on (DR mode only).
	The High Power laser pointer is on.
	The radio signals from the robotic instrument are no longer being received.
	The compensator is disabled.
	Auto-connect is disabled. Tap the icon once to restart Auto connect. Tap the icon again to view the <i>Auto connect options</i> screen.
	The prism is locked by the robotic instrument. The prism constant (in millimeters) and target height are shown to the right of the icon. "1" indicates that target 1 is in use.
	The target icon changes to a DR icon to show that the instrument is in Direct Reflex mode.
	The target icon rotates to show that the conventional instrument has Autolock enabled but is not currently locked on to a target.
	FineLock is enabled.
	Long Range FineLock is enabled
	GPS Search is enabled.
	Interrupted Target Measurement is enabled
	
	A static point is being measured.
	Radio signals are being received.

Icon	What it shows
	Radio signals are no longer being received.
	Cellular modem signals are being received.
	Cellular modem has hung up, or has stopped receiving corrections.
	Radio signals are being received. xFill® is ready to provide RTK if required.
	Radio signals are no longer being received. xFill is enabling RTK to continue.
	SBAS/OmniSTAR® signals are being received.
	Data is being received from the RTX satellite but an RTX position cannot be generated yet.
	An RTX survey is running but data is not being received from the RTX satellite.
	Continuous points are being measured.
	If no survey is running, the number of satellites being tracked is shown to the right of the icon. If a survey is running, the number of satellites in the solution is shown to the right of the icon.
	A real-time survey is running and base data from a network connection is being streamed to the rover.
	Real-time base data streaming from a network connection is paused. Base data streaming automatically restarts when required.
	A real-time survey is running and base data from a network connection is being received but the solution from the receiver is not yet using that base data.
	A real-time survey with base data from a network connection is stopped. The base station network connection is maintained, but the real-time base data will not be streamed to the rover.
	A real-time survey is running but base data from a network connection cannot be received.

In a conventional survey, you can tap the status bar icons to access related screens as described below:

Icon	Related screen
	Instrument functions Tap and hold to access the instrument settings
	Target details You can then change targets and edit the target height and prism constant

In a GNSS survey, you can tap the status bar icons to access related screens as described below.

Icon	Related screen
	Receiver status
	Sky plot
	GNSS functions Tap and hold to access the receiver settings
	Antenna details You can then edit the antenna measurement method and antenna height

Status line

The status line is displayed on the bottom of the screen. It displays a message when an event or action occurs, and when the General Survey software cannot start or continue with its present function.

When the controller is connected to a receiver, the status line displays the current survey mode. The following table explains these modes.

Survey mode	Explanation
No Survey	The receiver is connected but a survey has not been started.
RTX	The current survey type is RTX.
RTK:Fixed	The current RTK survey is initialized, and the solution type is L1 fixed-centimeter-level.
RTK:Float	The current RTK survey is not initialized, and the solution type is L1 float.
RTK:Check	The current RTK survey is verifying the initialization.
RTK:Auton	The radio link is down in the current RTK survey, and the solution is an autonomous position.
RTK:SBAS	The radio link is down in the current RTK survey, and the solution is an SBAS position
OmniSTAR VBS	The current survey type is OmniSTAR VBS (differentially corrected)
OmniSTAR HP	The current survey type is OmniSTAR HP (high-precision)
xFill	Radio signals are no longer being received. xFill or xFill-RTX is enabling RTK to continue.
FastStatic	The current survey type is FastStatic.
PPK:Initialized	The current postprocessed kinematic survey is initialized. When postprocessed, it should yield a centimeter-level solution.
PPK:Not initialized	The current postprocessed kinematic survey is not initialized. When postprocessed, it may not yield a centimeter-level solution.

Survey mode	Explanation
Infill:Initialized	The current postprocessed kinematic infill survey is initialized. When postprocessed, it should yield a centimeter-level solution.
Infill:Not initialized	The current postprocessed kinematic infill survey is not initialized. When postprocessed, it may not yield a centimeter-level solution.
Infill	The current survey type is differential, and you are doing an infill session.
SBAS	The current survey type is differential, and using signals from an SBAS.

The following table describes the status line icons for a GNSS survey when using a receiver equipped with HD-GNSS technology.

Icon	What it shows
✓	The precision tolerances have been met.
✗	The precision tolerances have not been met.

General Survey buttons

Enter	Tapping the <i>Enter</i> button on the controller is the same as tapping the Enter key on the controller keypad. The actions of the <i>Enter</i> button depend on the current screen. In some screens, the caption on the button changes to describe the action for the screen. For example, the <i>Enter</i> button changes to the <i>Measure</i> button when you are in the <i>Measure points</i> screen.
--------------	--

Map	Tap <i>Map</i> to display a map of the current job .
Menu	Tap <i>Menu</i> to return to the main menu.
Favorites	Tap <i>Favorites</i> to access a list of commonly used screens. See the <i>Favorites</i> menu below.
Switch to	Tap this button to switch between active windows (screens).

Note - The up arrow softkey appears if there are more than four softkeys associated with a screen. Tap the arrow or press the **Shift** key to see the other softkeys.

Tip - To highlight a field without selecting it, tap and hold briefly with the stylus.

Favorites menu

The *Favorites* menu provides quick access to commonly used screens and to various commands when connected to a conventional instrument or GNSS receiver. Access a screen or command from the *Favorites* list, or use the *Switch to* button to access previously viewed screens.

To access a screen or command from the *Favorites* list, tap the *Favorites* button and then select the screen you want.

To add a screen to the *Favorites* list, view it and select *Favorites / Add to favorites*.

To add a command to the *Favorites* list:

1. Tap *Favorites / Customize / Add a command to Favorites menu*.
2. Tap the command you want to add.

To remove a command or form:

1. Tap *Favorites / Customize / Remove command from Favorites menu*.
2. Tap the item you want to remove.

Customizing controller keys

The App keys on controllers can be configured from the operating system on the controller, primarily to perform hardware key functions, or within the Trimble Access software, to perform software functions.

To configure the keys to perform hardware key functions, tap *Start / Settings / Personal / Buttons* and then set the *Left softkey* or *Right softkey* to the appropriate function. Then, in General Survey, tap *Favorites / Customize / Assign a command to App Button 1* or *Assign a command to App Button 2* and make sure you set the App key to *Use OS setting*.

To customize the App keys to perform software functions, see the sections below.

Customizing the App keys on a Slate/GeoXR/TSC2/TSC3 controller

The **Left App** key and the **Right App** key provide quick access to commonly used screens or commands. To customize the **App** keys:

1. Run the General Survey software.
2. To assign a form to an **App** key, browse to that form.
 - For a TSC2/TSC3 controller - from the main menu, tap *Favorites / Customize / Assign a command to App Button 1* or *Assign a command to App Button 2*.
 - For a Slate/GeoXR controller - from the main menu, tap *Switch to / Customize / Assign a command to App Button 1* or *Assign a command to App Button 2*.
3. Do one of the following:
 - If you have browsed to a specific form, select the form name at the top of the list.
 - To return to the default settings, select *None*.
 - Select an instrument or GNSS command. Several are available by default.

Tip - To assign a new command to an **App** key on a TSC2/TSC3 controller press CTRL + **App** key to access the selection menu.

Customizing the App keys on a Geo7X controller

The **Left App** key and the **Right App** key provide quick access to commonly used screens or commands. To customize the **App** keys:

1. Run the General Survey software.
2. To assign a form to an **App** key, browse to that form.
3. Tap *Start / Settings / Personal / Buttons*.
4. To specify the action for the key, do one of the following:

- Tap the *Program Buttons* tab.
 - Tap a button in the list to select it.
 - From the *Assign a program* drop-down list, select the action you want to occur when you press the **App** key.
5. Tap *OK*.

Customizing the function keys on a Trimble tablet

The **F1**, **F2** and **F3** function keys provide quick access to commonly used screens or commands. To customize the function keys:

1. Run the General Survey software.
2. If you want to assign a form to a key, browse to that form and from the main menu, tap *Favorites / Customize / Assign a command to F1* or *Assign a command to F2* or *Assign a command to F3*.
3. Do one of the following:
 - If you have browsed to a specific form, select the form name at the top of the list.
 - To return to the default settings, select *None*.
 - Select an instrument or GNSS command. Several are available by default.

Softkeys

Softkeys are displayed on the bottom line of the General Survey screen as on-screen buttons. They relate to particular screens and change when the screens change.

To access the softkeys using the keyboard:

- On a Trimble TSC2/TSC3 controller and Trimble tablet, press **Ctrl** and then press **1**, **2**, **3**, or **4** for softkeys *F1*, *F2*, *F3*, or *F4* respectively. To see the second row of softkeys, press **Shift**.
- On a Trimble CU, Trimble M3 total station, and Trimble S3 total station, press **Ctrl** and then **1**, **2**, **3**, or **4** for softkeys *F1*, *F2*, *F3*, or *F4* respectively. To display the second row of softkeys, press **Ctrl** and then **5**.

Shortcuts

General Survey shortcuts

To...	Do the following
Select an underlined menu item	Press the key corresponding to the underlined menu item
Display the map	CTRL M from anywhere
Display the menu	CTRL E from anywhere
Display Favorites	CTRL A from anywhere

To...	Do the following
Switch to	CTRL W from anywhere
Scroll through the list of <i>Switch to</i> functions	CTRL TAB
Key in Notes	CTRL N
Measure Check shot	CTRL K
Show or Hide eBubble	CTRL L
Switch between a GNSS and a conventional survey	Tap in the status line area at the bottom of the screen
Sort columns	Tap the column heading. Tap the column heading again to reverse the sort order. Note - <i>Not all column headings support this.</i>
Softkeys F1, F2, F3, F4	CTRL 1, 2, 3, 4 respectively
Access the second row of softkeys	SHIFT Note - <i>On a TCU, press CTRL + 5</i>
Select a check box or button	SPACE
Move between fields	Up arrow, Down arrow, TAB, Back TAB
Open a dropdown list	Right arrow
Select items in dropdown lists	Press the first character of the list item. If multiple items start with the same character, press the first character again to move through the list.
Widescreen on/off	. (full stop or period)
Delete jobs	On a TSC3 or TSC2: FN + DEL On a TCU / tablet: CTRL + DEL
To select multiple fields in Point manager	Press and hold CTRL and then tap the fields, or use SHIFT and then tap the fields at the start and end of your selection.
Navigate to a particular group of codes	Press A to Z to move to group pages 1 to 26. Key A opens group 1, Key B opens group 2... and key Z opens group 26. Note - <i>This method is not available if the Code button is enabled.</i>
Initiate a measurement using	Press the numeric key on the controller keyboard corresponding to the button for the code.

To...	Do the following
measure codes	When the buttons are set to a 3 x 3 layout, keys 7, 8, 9, activate the top row of buttons, keys 4, 5, 6 activate the middle row of buttons, keys 1, 2, 3 activate the bottom row of buttons.
Compute a distance between two points	Enter the point names in the distance field, separated by a hyphen. For example, to compute the distance between points 2 and 3, enter "2-3". Note - This method works with most alphanumeric point names, but it does not support point names that already contain a hyphen.
Compute an azimuth from two points	Enter the point names in the Azimuth field, separated by a hyphen. For example, to compute the azimuth from point 2 to point 3, enter "2-3". Note - This method works with most alphanumeric point names, but it does not support point names that already contain a hyphen.
Copy	CTRL C
Paste	CTRL V
Open the Functions menu	Press and hold the Trimble key (if available) on the controller keyboard.
Display the target/prism selection panel	CTRL P

Controller-specific shortcuts

Controller	To...	Do the following
TSC3/TSC2/TCU	Open/Close Keyboard panel	CTRL 7
TCU/S3/M3	Open Control Panel	CTRL, ESC [Settings / Control Panel]
TCU/S3/M3	Disable/Enable touch screen	CTRL + Trimble key
All	Display Start menu	CTRL + ESC
TSC2/TSC3	Soft reset/Warm boot	Hold Power key for about 10 seconds and then release
TCU 1 and 2	Soft reset/Warm boot	Hold CTRL + 1 and then press and release 9
TCU 3	Soft reset/Warm boot	Hold Power key and then select <i>Options / Reset</i>
Slate/Geo7X/GeoXR	Soft reset/Warm boot	Hold Power key and then select <i>Reset</i>

Controllers

The functionality supported in each controller is as follows:

Controller	BlueTooth	Wi-Fi	Internal modem	Internal GPS	Internal Camera	Internal Compass
Trimble CU	*	-	-	-	-	-
TSC2	*	*	-	-	-	-
TSC3	*	*	*	*	*	*
Trimble tablet	*	*	-	*	*	*
Trimble Slate controller	*	*	*	*	*	*
Trimble GeoXR	*	*	*	*	*	-
Trimble Geo7X	*	*	*	*	*	-

Note - Reference to a Trimble CU refers to all versions of the Trimble CU including the Trimble CU (Model 3) controller. When required, the Trimble CU (Model 3) controller is specifically mentioned. A Trimble CU (Model 3) controller can be identified by the label on the back.

File storage on Trimble controllers

Trimble controllers have similar RAM and flash storage.

In all controllers, the RAM storage is volatile and is shared between storage memory and program memory.

- Storage memory is required for such things as the operating system, and installing programs.
- Program memory is required to run programs. When program memory is low, programs may run slowly, become unresponsive, or even crash.

Flash memory is permanent, so data is not lost if the controller loses power or after a hard reset. However, as with a computer hard disk, this storage may occasionally fail.

Power indicators

The remaining battery power is displayed as a battery symbol in the status bar.

The symbol on the top represents the power remaining in the Trimble controller battery, or when using a Trimble CU the power remaining in the Trimble Robotic or GNSS holder battery.

For the Trimble M3 total station the symbol on the top represents the power remaining in the left hand battery on the instrument and the lower battery symbol represents the power remaining in the instrument's right hand battery.

The symbol below the top battery symbol represents the remaining power in an external power supply, such as from a GNSS receiver or conventional instrument. (This symbol only appears when an external power supply is connected.)

The level of shading in the symbol reduces as the power reduces.

Controller-specific information

Use the links below to find out specific information for your controller type:

[Trimble TSC3 controller](#)

[Trimble TSC2 controller](#)

[Trimble tablet](#)

[Trimble CU controller](#)

[Trimble Geo7X handheld](#)

[Trimble GeoXR handheld](#)

[Trimble Slate controller](#)

[Trimble S3 controller](#)

[Trimble M3 total station](#)

Trimble TSC3 controller

The TSC3 controller supports a larger screen with a higher resolution than the TSC2 controller. It also has a new operating system.

The TSC3 controller supports the following key features:

Internal GPS

The internal GPS can be used to navigate to a point, to store a position, and for a GPS search. GPS search is automatically enabled but a connected GNSS receiver is always used in preference to the internal GPS.

Internal compass

The internal compass provides an aid to navigation.

Internal camera

The 5 megapixel camera can be used to capture and attach an image to a point.

Internal cellular modem

The integrated GSM/mobile internet modem enables wireless Internet connectivity.

Keys

The following table describes the General Survey software functions that are associated with the controller keys.

Key Function



Start the Trimble Access menu.

Short press: Access the menu of available applications that are currently running, including the Trimble Access menu.

Long press: Access Trimble Functions.



You can customize the [Left App] button and the [Right App] button on to perform your most used functions in the General Survey software.

For details on how to set this up, see [Customizing the App keys on a Slate/GeoXR/TSC2/TSC3 controller](#).



The Ok button relates to the icon available at the top right corner of the screen.

If the icon shows [Ok], then the Ok button saves and closes the form.

If the icon shows an [X], tap the icon or the press the [Ok] button to hide the General Survey software.

Note - If you tap [X] while the controller is connected to an instrument or GNSS receiver, the connection is not broken when the General Survey software is hidden.

Configuring the system options

New General Survey systems are shipped unconfigured. They are configured automatically when you connect the controller to the instrument. Alternatively, select *Settings / Connect / Survey styles / Options* and then select the option(s) appropriate for you:

- GNSS users - select *GNSS surveying*
- Conventional Total Station users - select *TS surveying*

For more information, refer to the *General Survey Help* or contact your local Trimble reseller.

These options control the styles that are available and the relevant options that appear throughout the software. You can reconfigure the General Survey system at any time.

Controller operation

Touch screen

Calibrating the touch screen

1. Tap [Start / Settings / System / Screen].
2. Tap [Align Screen] and follow the prompts. If the calibration is successful, the [Settings] screen appears at the end of the calibration process. If the calibration was not successful, the target returns to the center of the screen and you must repeat the process.

Disabling the touch screen

To disable the Trimble TSC3 touch screen, press [Fn]+  key.

This disables the screen, but not the keypad. The touch screen remains disabled until you press [Fn] +  key again or until you reset the controller.

Changing the speaker volume

Press Windows Start and then tap the sound icon at the top of the screen. From the panel of options, select the sound icon and then use the slider to increase or decrease the volume for the controller. Tap [Off] to mute.

Camera

By default, the camera resolution is set to the second lowest value. You may want to change this setting to obtain better-quality images. To do this, from in the Trimble Access software, press (Fn + 1) or from the General Survey menu, tap *Instruments / Camera*. Tap *Menu / Resolution*.

Backlight

On a TSC3 controller, press (**Fn + 9**) to enable or disable the backlight. To configure the settings, press the Windows button to access the *Start* menu and then tap [Setting / System / Backlight].

File Explorer

To start File Explorer on a TSC3 controller, press the Windows button and from the *Start* menu tap [File Explorer].

You can also start File Explorer from the Trimble Access menu.

Folders and files that appear in File Explorer are those from Flash storage.

For more information, refer to the Windows Help provided on the controller.

Deleting files

Use *Jobs / Open job* to copy and delete job files. If you delete job files, any associated GNSS files are automatically deleted.

Use File Explorer to delete all other file types.

WARNING - Files deleted in File Explorer cannot be recovered.

Using the keypad to run programs

- To run a program from the [Start] menu:

Press **Ctrl** then **Esc** to display the [Start] menu, then use the arrow keys to select [Programs].

Press **Enter** to display a list of programs, then use the arrow keys to select the program that you want to run. Press **Enter** to run the program.

- If there is no icon or [Start] menu listing:

If there are no icons highlighted on the desktop, press the **Tab** key until one is selected, then use the arrow keys to select [My Computer]. In [My Computer], use the arrow keys to highlight the Disk folder, then press **Enter**. Use the arrow keys to locate the program you want to run (it may be located in a sub folder), then press **Enter** to run the program.

Resetting the controller and troubleshooting

Performing a soft reset (warm boot)

You do not lose any data when you perform a soft reset.

To soft reset the TSC3 controller, hold down the **Power** key. After about five seconds, a countdown timer appears, indicating that the controller will reset. Continue to hold down the **Power** key for a further five seconds and then release it. The controller briefly displays the boot screen and then resets to the default Microsoft Windows desktop view.

Performing a hard reset (cold boot)

Trimble recommends you do not perform a hard reset on a Trimble TSC3 controller. Perform a soft reset, and if that does not resolve the issues, contact your local Trimble reseller.

Getting rid of out of memory errors

Memory is managed automatically. If you run out of memory, close programs you no longer need. To do this, select [Start / Settings / System / Task manager], select a program you no longer need and then tap *End task*.

Device connection and file transfer issues issues

Microsoft Explorer and the Trimble Data Transfer utility may sometimes fail to find the folders and to show files on the controller. This can occur if another Explorer window is still browsing to the controller from a previous connection, or if the controller has been reset and a new connection made. To avoid this, make sure that you close all Explorer windows before you disconnect the controller.

Replacing the battery

1. Hold down the power button for a few seconds but release it before the controller resets.
2. From the *Power* menu, select *Replace Battery/SIM*.
3. When prompted to replace the battery/SIM, tap *Yes*.



Notes

- *The controller will be placed in a low powered state and the screen will go black.*
 - *Do not press the power button until the new battery/SIM has been replaced.*
 - *You have one minute to replace the battery/SIM and turn on the controller.*
4. Replace the battery and turn the controller on again.

Trimble TSC2 controller

Keys

The following table describes the General Survey software functions that are associated with the controller keys.

Key	Function
	<p>Start the Trimble Access menu.</p> <p>Short press: Access the menu of available applications that are currently running, including the Trimble Access menu.</p> <p>Long press: Access Trimble Functions.</p>
	<p>You can customize the [Left App] button and the [Right App] button to perform your most used functions in the General Survey software.</p> <p>For details on how to set this up, see Customizing the App keys on a Slate/GeoXR/TSC2/TSC3 controller.</p>
	<p>The Ok button relates to the icon available at the top right corner of the screen.</p> <p>If the icon shows [Ok], then the Ok button saves and closes the form.</p> <p>If the icon shows an [X], tap the icon or the press the [Ok] button to hide the General Survey software.</p> <p>Note - <i>If you tap [X] while the controller is connected to an instrument or GNSS receiver, the connection is not broken when the General Survey software is hidden.</i></p>

Configuring the system options

New General Survey systems are shipped unconfigured. They are configured automatically when you connect the controller to the instrument. Alternatively, select *Settings / Connect / Survey styles / Options* and then select the option(s) appropriate for you:

- GNSS users - select *GNSS surveying*
- Conventional Total Station users - select *TS surveying*

For more information, refer to the *General Survey Help* or contact your local Trimble reseller.

These options control the styles that are available and the relevant options that appear throughout the software. You can reconfigure the General Survey system at any time.

Controller operation

Touch screen

Calibrating the touch screen

1. Tap [Start / Settings / System / Screen].
2. Tap [Align Screen] and follow the prompts. If the calibration is successful, the [Settings] screen appears at the end of the calibration process. If the calibration was not successful, the target returns to the center of the screen and you must repeat the process.

Disabling the touch screen

To disable the Trimble TSC2 touch screen, press [Fn]+ key.

This disables the screen, but not the keypad. The touch screen will remain disabled until [Fn]+ key is pressed again or the controller is reset.

Changing the speaker volume

On the controller there are two places to control sounds.

Tap the speaker icon on the start bar and then use the slider to increase or decrease the volume. Tap [Off] to mute.

To modify other sound events such as program notifications and screen taps:

1. Tap [Start / Settings / Sounds & Notifications].
2. Configure the various sound controls as appropriate.

Backlight

On a TSC2 controller, press the Windows button and tap [Settings / System / Backlight] to configure the backlight settings.

File Explorer

To start File Explorer on a TSC2 controller press the Windows button and then tap [Programs / File Explorer].

You can also start File Explorer from the Trimble Access menu.

Folders and files that appear in File Explorer are those from Flash storage.

For more information, refer to the Windows Help provided on the controller.

Deleting files

Use *Jobs / Open job* to copy and delete job files. If you delete job files, any associated GNSS files are automatically deleted.

Use File Explorer to delete all other file types.

WARNING - Files deleted in File Explorer cannot be recovered.

Using the keypad to run programs

- To run a program from the [Start] menu:
Press **Ctrl** then **Esc** to display the [Start] menu, then use the arrow keys to select [Programs]. Press **Enter** to display a list of programs, then use the arrow keys to select the program that you want to run. Press **Enter** to run the program.
- If there is no icon or [Start] menu listing:
If there are no icons highlighted on the desktop, press the **Tab** key until one is selected, then use the arrow keys to select [My Computer]. In [My Computer], use the arrow keys to highlight the Disk folder, then press **Enter**. Use the arrow keys to locate the program you want to run (it may be located in a sub folder), then press **Enter** to run the program.

Resetting the controller and troubleshooting

Performing a soft reset (warm boot)

You do not lose any data when you perform a soft reset.

To soft reset the TSC2 controller, hold down the **Power** key. After about five seconds, a countdown timer appears, indicating that the controller will reset. Continue to hold down the **Power** key for a further five seconds and then release it. The controller briefly displays the boot screen and then resets to the default Microsoft Windows desktop view.

Performing a hard reset (cold boot)

Trimble recommends you do not perform a hard reset on a Trimble TSC2 controller. Perform a soft reset, and if that does not resolve the issues, contact your local Trimble reseller.

Getting rid of out of memory errors

Memory is managed automatically. If you run out of memory, select [Start / Settings / System / Memory / Running Programs] and stop the running programs you no longer need.

Connecting a TSC2 controller to wireless devices

When you connect a TSC2 controller to a device using wireless technology, the icon on the status bar at the top of the screen should be animated, showing that the connection is being attempted. Once the controller is connected, the icon should appear as two large arrows. This functions correctly in the operating system version 5.0.2, but not in version 5.0.3. However, if you click the icon, the *Connectivity* dialog correctly shows the connection status.

Device connection and file transfer issues issues

Microsoft Explorer and the Trimble Data Transfer utility may sometimes fail to find the folders and to show files on the controller. This can occur if another Explorer window is still browsing to the controller from a previous connection, or if the controller has been reset and a new connection made. To avoid this, make sure that you close all Explorer windows before you disconnect the controller.

Trimble tablet

The Trimble tablet controller supports a large high-resolution screen and the following key features:

Internal GPS

The internal GPS can be used to navigate to a point, to store a position, and for a GPS search. GPS search is automatically enabled but a connected GNSS receiver is always used in preference to the internal GPS.

Internal camera

Use the internal forward facing 5 megapixel camera to capture and attach an image to a point.

2.4 GHz USB radio

A 2.4 GHz USB radio is available for robotic surveys with the Trimble tablet. This radio is integrated in that it attaches to the back of the tablet. Alternatively you can connect an external radio via cable to a USB port on the tablet.

To set up the radio, establish an Internet connection with the Trimble tablet and then connect the radio to the tablet using the USB cable supplied. The drivers are then installed automatically. Alternatively, tap the Trimble button to access the *Start menu*, and then tap [All programs / Trimble Access Drivers] and run USBRadioDriver.exe.

Trimble TabletSync

The TabletSync utility can be installed on a Trimble tablet along with the Trimble Access software, and used to easily transfer and synchronize data files between the Trimble tablet and a host computer using a local area network (wired or wireless).

Note - The Trimble tablet does **not** support the Monitoring application.

Managing anti-virus software and Windows updates on the Trimble tablet

- Trimble recommends installing anti-virus software on the Trimble tablet, just like you do on all other computers
- Windows updates should be applied before using the Trimble Access Installation Manager to install Trimble Access software updates.
- Trimble recommends that Windows updates and anti-virus updates are not scheduled at times when you are working in the field.

Connections to the office

The Trimble tablet is a Windows PC. It cannot use Windows Mobile® Device Center to connect to the office PC. Alternative file transfer options include:

- Using the Trimble Connected Community directly on the Trimble tablet in the same way as on an office PC.
- Using the new Trimble Connected Community Explorer utility to upload/download files between the Trimble tablet and the Trimble Connected Community. It makes an organizations file and folder structure in the Trimble Connected Community available in [My Computer] and Windows Explorer areas of the Trimble tablet.
- Using AccessSync, which allows you to send data back and forth to your Trimble Connected Community organization. You are entitled to install and run this service if you have a valid software maintenance agreement or if you have purchased Advanced Trimble Access services. For more information browse to <http://mytrimbleaccess.com>
- Using the new Trimble TabletSync utility, which can be installed on a Trimble tablet along with the Trimble Access software, allows you to easily transfer and synchronize data files between the Trimble tablet and a host computer using a local area network (wired or wireless).
- Adding the Trimble tablet to a network
 - Network/Internet connections:
 - Wi-Fi
 - Ethernet cable using a USB adaptor or a docking station
 - Cellular modem connected by Bluetooth, USB, or express card
 - Using an USB memory stick

Note - Some third party devices may require you to use their own proprietary software to establish an Internet connection outside the Trimble Access software. The Trimble Access software will use an existing Internet connection if this is available.

Connecting or transferring data to other devices

- Bluetooth
- USB cable

Note - To establish a connection to an Trimble R10 receiver, you must first install a suitable driver. To do this, tap Windows Start to access the Start menu, tap [All programs / Trimble Access Drivers] and then run Win7_USB_Installer.exe.

- USB stick
- Wireless ad-hoc (computer-to-computer) network

Trimble tablet operation

Trimble keyboard

The Trimble keyboard is installed with Trimble Access on a Trimble tablet.

Trimble keyboard tips:

- The Trimble keyboard automatically appears when you tap in a field.
- When you tap in an alphanumeric field, the alphanumeric keys are displayed.
- To change between alphanumeric and symbol keys, tap **ABC / Sym**.

- Tap **Enter** to confirm your entry and close the keyboard.
- Tap **Tab** to confirm your entry and move to the next field without closing the keyboard.
- Tap **Esc** to clear any changes made to the current field and hide the keyboard.
- To use Shift, tap the Shift (arrow) key.
- To use CAPS lock, tap the Shift (arrow) key twice.
- To highlight the entry in a field, tap the Shift (arrow) key and then tap in the field. The contents of the field are selected.

Touch screen

Calibrating the touch screen

1. Tap the Trimble button to access the *Start menu*, and then select [Control Panel / Tablet PC Settings].
2. From the [Display] tab, tap [Calibrate...], and follow the prompts. Save the calibration.

Disabling the touch screen

You cannot disable the touch screen on the Trimble tablet.

Changing the speaker volume

Tap the sound icon and then use the slider to increase or decrease the volume. Tap the sound icon at the base of the volume slider to mute.

Backlight

On a Trimble tablet, the backlight is always enabled. To configure the display, tap the Trimble button to access the *Start menu*, and then tap [Control Panel - Display].

Windows Explorer

Use Microsoft Windows Explorer to view and manage files stored in a Trimble tablet controller. To start Windows Explorer, tap the Trimble button to access the *Start menu*, and then tap the Windows Explorer icon.

You can also start Microsoft Windows Explorer from the Trimble Access menu.

For more information, refer to the Windows Help provided on the controller.

Deleting files

Use *Jobs / Open job* to copy and delete job files. If you delete job files, any associated GNSS files are automatically deleted.

Use Windows Explorer to delete all other file types.

WARNING - Files deleted in Windows Explorer cannot be recovered.

Trimble CU controller

Note - Reference to a Trimble CU refers to all versions of the Trimble CU including the Trimble CU (Model 3) controller. When required, the Trimble CU (Model 3) controller is specifically mentioned. A Trimble CU (Model 3) controller can be identified by the label on the back.

Attaching and detaching the controller







To **attach** the controller to the Trimble VX Spatial Station or Trimble S Series total station, the controller holder, or the docking station, place the top of the controller onto the hot shoe connector and then gently push the bottom of the controller downward until it clips firmly into place.

To **detach** the controller from the Trimble VX Spatial Station or Trimble S Series total station, the controller holder, or the docking station:







1. Switch off the Trimble CU. This suspends the controller, and prevents it from rebooting next time you apply power.
2. Push in the clip at the bottom of the CU and then gently pull the bottom of the CU outward until the controller is released.

Keys

The following table describes the General Survey functions that are associated with the Trimble CU controller keys.

On this instrument or receiver...	tap... to...
Conventional or GNSS	 change between 123, ABC, and abc keyboard entry modes
	 modify the action of the other key that you tap in conjunction
	 tab between fields
	 activate the Enter button
Conventional	 start or switch to the Trimble Access menu
GNSS	 start or switch to the Trimble Access menu

The following table describes the General Survey functions that are associated with the Trimble VX Spatial Station or Trimble S Series total station keys when the controller is attached to the instrument and General Survey is running.

On the instrument press...	to...
 (short press)	activate the Enter button
 (long press)	power the instrument and controller on and off
 (short press)	change face
 (short press)	scroll between the face 1 view displays
 (long press)	switch the face 2 backlight on or off
 (short press)	activate the <i>Enter</i> button

When taking measurements the face 2 display shows the same measurement information as the view display button on the *Measure topo* and *Station setup* forms on face 1. This is typically horizontal angle, vertical angle and, after a measurement, the slope distance. To scroll through the different views, press the  key. Information such as current measurement status appears in the face 2 status line at the bottom of the display.

When a duplicate observation is encountered the face 2 display shows delta Horizontal angle, delta horizontal distance and delta vertical distance.

Note - Before you store the point, confirm the *Store as* action in the face 1 display.

Use the face 2 keys to control the instrument's onboard applications when the controller is not attached to the instrument. For more information, refer to the documentation for your instrument.

Configuring the system options

The new General Survey systems are shipped unconfigured. They are configured automatically when you connect the controller to the instrument. Alternatively, select *Settings / Connect / Survey styles / Options* and then select the option(s) appropriate for you:

- GNSS users - select *GNSS surveying*
- Conventional Total Station users - select *TS surveying*

For more information, refer to the *General Survey Help* or contact your local Trimble reseller.

These options control the styles that are available and the relevant options that appear throughout the software. You can reconfigure the General Survey system at any time.

Connecting a Trimble CU controller to the office computer

The Trimble CU controller communicates through the docking station to the office computer using USB. The docking station must be connected to the office computer through the USB-to-Hirose cable.

You cannot connect the Hirose-to-7-pin lemo cable to a 7-pin lemo-to-DB9 cable (supplied with GNSS systems) and use this to connect the docking station to the serial port on the office computer.



Controller operation

Touch screen

Calibrating the touch screen

Open the Control Panel (**Ctrl, Esc, [Settings / Control Panel]**) then select the [Stylus] icon. In the [Stylus Properties] dialog select the [Calibration] >tab. Tap [Recalibrate] and follow the prompts, using the stylus to tap the target as it moves from the center of the screen, to each corner. If the calibration is successful, you are prompted to press **Enter** to accept the new settings. If the calibration was not successful, the target returns to the center of the screen and the process must be repeated.

Disabling the touch screen

To disable the Trimble CU touch screen, press [Ctrl]+  key. This disables the screen, but not the keypad. The touch screen will remain disabled until you press [Ctrl]+  again or you reset the controller.

You can disable the Trimble CU touch panel disabled notice: Tap [Start / Settings / Control Panel] in the [Touch Pad Disable] tab of the [Stylus Properties] screen and then clear the [Show notice each time touch is disabled] check box.

Changing the speaker volume

Open the Windows CE Control Panel (**Ctrl, Esc, S, C**) then select the Volume and Sounds icon. Use the slider to increase or decrease the volume. You can also use this dialog to turn on or off individual sounds, such as tapping the screen.

Backlight

On a Trimble CU controller, tap [Start / Settings / Control panel / Keyboard / Backlight] to enable or disable the keyboard backlight.

Windows Explorer

Use Microsoft Windows CE Explorer to view and manage files stored in a Trimble CU controller.

To start Windows Explorer, tap [Start / Programs / Windows Explorer].

You can also start Microsoft Windows CE Explorer from the Trimble Access menu.

For more information, refer to the Windows Help provided on the controller.

Deleting files

Use *Jobs / Open job* to copy and delete job files. If you delete job files, any associated GNSS files are automatically deleted.

Use Windows Explorer to delete all other file types.

WARNING - Files deleted in Windows Explorer cannot be recovered.

Using the keypad to run programs

- To run a program from the [Start] menu:
Press **Ctrl** then **Esc** to display the [Start] menu, then use the arrow keys to select [Programs]. Press **Enter** to display a list of programs, then use the arrow keys to select the program that you want to run. Press **Enter** to run the program.
- If there is no icon or [Start] menu listing:
If there are no icons highlighted on the desktop, press the **Tab** key until one is selected, then use the arrow keys to select [My Computer]. In [My Computer], use the arrow keys to highlight the Disk folder, then press **Enter**. Use the arrow keys to locate the program you want to run (it may be located in a sub folder), then press **Enter** to run the program.

Resetting the controller and troubleshooting

Performing a soft reset (warm boot)

You do not lose any data when you perform a soft reset.

- To reset the Trimble CU, hold down the **Ctrl** key and the **1** key, then press and release the **9** key.
- To reset the Trimble CU (Model 3) controller, hold down the **Power** key and then select **Options / Reset**.

Performing a hard reset (cold boot) on a Trimble CU controller

Perform a hard reset only if a soft reset fails to resolve an issue. After a hard reset, the operating system is reloaded into RAM from the Flash memory. Some software programs may also store shortcuts or database information in RAM; this is erased during a hard reset.

To perform a hard reset, hold down the **Power** key. After about five seconds, a countdown timer appears, indicating that the controller will reset. Continue to hold down the **Power** key for a further five seconds, then release it. The controller briefly displays the boot screen and then resets to the default Microsoft Windows desktop view.

Performing a hard reset (cold boot) on a Trimble CU (Model 3) controller

Trimble recommends that you do not perform a hard reset on a Trimble CU (Model 3) controller. If a soft reset does not resolve the issues, contact your local Trimble reseller.

Getting rid of out of memory errors

Trimble CU (Model 3) controller:

Memory is managed automatically. If you run out of memory, select [Start / Settings / System / Memory / Running Programs] and stop the running programs you no longer need.

Trimble CU controller:

Open the Control Panel (**Ctrl, Esc, S, C**) then select the [System] icon. In the [System Properties] screen, select the [Memory] tab, then move the slider-bar to the left to increase the amount of RAM memory allocated to running programs.

Device connection and file transfer issues

Microsoft Explorer and the Trimble Data Transfer utility may sometimes fail to find the folders and to show files on the controller. This can occur if another Explorer window is still browsing to the controller from a previous connection, or if the controller has been reset and a new connection made. To avoid this, make sure that you close all Explorer windows before you disconnect the controller.

Pairing a Trimble tablet with a Trimble CU controller

To avoid time-out issues when pairing a Trimble tablet with a Trimble CU controller, Trimble recommends that you promptly enter a short pairing code.

Trimble CU Suspend mode

The Trimble CU takes its power from an external power source, such as an instrument, Robotic Holder, GNSS Holder, or a docking station.

The Trimble CU controller has an internal battery used while in suspend mode. Suspend mode enables you to remove the controller from one power source and then attach it to another power source within a time period that you define. You can then resume working from the same place in the software that you were before you turned off the controller.

After the suspend time has elapsed, the battery automatically shuts down and the Trimble CU has to reboot when starting again. If the internal battery runs low on power the Trimble CU powers down sooner. Fully charged and under normal conditions, the internal battery should have capacity for five suspend sequences.

Note - Before you remove the Trimble CU from its power source, press the power button to turn off the controller. Otherwise the controller has to reboot when it restarts.

To configure the power settings on the Trimble CU (Model 3) controller:

1. Tap the [Start] menu and then select [Settings / Control Panel / Power].
2. Use the [PowerOff] tab to configure the suspend state when connected using external power and battery power.
3. Use the [Battery] tab to show the current power status.

To configure the power settings on the Trimble CU:

1. Tap the [Start] menu and then select [Settings / Control Panel / Power].
2. Use the [Schemes] tab to configure the suspend state when connected using external power and battery power.

3. Use the [Systems Power] tab to display the current power status.
4. Use the [Power Key] tab to configure how the system behaves when the power key is pressed.

Trimble Geo7X handheld

Note - To use a Geo7X with Trimble Access version 2016.00, the Geo7X operating system must be version 6.7.16.64960 or later. To upgrade the operating system, go to www.trimble.com/Survey/Trimble-Geo-7x.aspx and then click Support.

The Trimble Geo7X supports GNSS surveys (no conventional support).

The Trimble Geo7X supports the following key features:

Internal GNSS

The internal GNSS can be used for all survey operations including measure and stakeout.

The receiver will start automatically when an application is started.

Internal orientation sensors

The Trimble Geo7X has a built-in compass, accelerometer, and gyroscope, enabling you to determine orientation and tilt when using the laser rangefinder module.

Internal camera

The 5 megapixel camera can be used to capture and attach an image to a point.

Internal cellular modem

The integrated GSM/mobile internet modem enables wireless Internet connectivity.

Optional rangefinder module

The rangefinder module enables you to complete many different types of measurement tasks including offsets, width, height, and angle measurements.

Note - When calibrating the sensors, make sure you perform the calibration away from all sources of magnetic interference.

Trimble Geo7X tips

- The Trimble Geo7X works only with the internal GNSS receiver. You cannot connect an external receiver to the Trimble Geo7X.
- The Trimble Geo7X cannot be used as a base.
- If you change the antenna during a survey, you are prompted to end the survey.
- Closing applications when not needed increases battery life.

Keys

The following table describes the General Survey software functions that are associated with the Trimble Geo7X controller keys.



Key Function

- | Key | Function |
|-----|--|
| 1 | Home/Power button. Use this button to turn on the Geo7X, place it in Suspend mode, wake it up from Suspend mode, and to return to the <i>Home</i> screen from whichever screen or application you are in. |
| 2 | Camera button. When in Trimble Access, press and hold, and then release the button to activate the camera. |
| 3 | The [Left App] button and the [Right App] button on the Trimble Geo7X controller provide quick access to the <i>Esc</i> and <i>Enter</i> buttons respectively.
You can customize the [Left App] button and the [Right App] button to perform your most used functions in the General Survey software. For details on how to set this up, see Customizing the App keys on a Geo7X controller . |

Status LEDs

Battery status

When the battery status light/led is:

- Green - battery charging is complete
- Orange - battery is charging
- Red and flashing - battery level is critically low
- Red - battery fault

GNSS receiver status

When the receiver status light/led is:

- Green and flashing - receiver is on and GNSS positions are available
- Orange and flashing - receiver is on but GNSS positions are not available
- Blue and flashing - receiver is starting or updating
- Red - GNSS fault

Wireless radio status

When the receiver status light/led is green and flashing one of the wireless connections (Wi-Fi, Bluetooth, or Phone) is turned on.

Handheld operation

Calibrating the touch screen

1. On the *Home* screen, tap the *Power* button and then tap 
2. Follow the on-screen instructions. If the calibration is not successful, the target returns to the center of the screen and you must repeat the process.

You cannot disable the touch screen on the Trimble Geo7X.

Calibrating the orientation sensors

Tap *Start / Settings / System / Sensor Calibration* and then follow the on-screen instructions. For more information, refer to the *Geo 7 Series User Guide*.

Aligning the rangefinder

If you have purchased the rangefinder module, you can align the rangefinder at any time. To do this, tap *Start / Settings / System / Laser Alignment* and then follow the on-screen instructions. For more information, refer to the *Geo 7 Series User Guide*.

Changing the speaker volume

Tap the Trimble button, select *Start Menu* and then tap the status bar at the top of the screen. Tap the Volume icon in the pull-down list, then drag the volume sliders as required.

Backlight

Tap the Trimble button, select *Start Menu* and then select [Settings / System / Backlight] to configure the backlight settings.

File Explorer

To start File Explorer, tap the Trimble button, select *Start Menu* and then tap [File Explorer].

You can also start File Explorer from the Trimble Access menu.

Folders and files that appear in File Explorer are those from Flash storage.

For more information, refer to the Windows Help provided on the controller.

Deleting files

In the Trimble Access menu, from the General Survey menu select *Jobs / Open job* to copy and delete job files. If you delete job files, any associated GNSS files are automatically deleted.

Use File Explorer to delete all other file types.

WARNING - Files deleted in File Explorer cannot be recovered.

Using the keypad to run programs

- To run a program from the [Start] menu:
Press **Ctrl** then **Esc** to display the [Start] menu, then use the arrow keys to select [Programs]. Press **Enter** to display a list of programs, then use the arrow keys to select the program that you want to run. Press **Enter** to run the program.
- If there is no icon or [Start] menu listing:
If there are no icons highlighted on the desktop, press the **Tab** key until one is selected, then use the arrow keys to select [My Computer]. In [My Computer], use the arrow keys to highlight the Disk folder, then press **Enter**. Use the arrow keys to locate the program you want to run (it may be located in a sub folder), then press **Enter** to run the program.

Resetting the handheld and troubleshooting

Performing a soft reset (warm boot)

To force an application to close, tap *Start / Settings / Task Manager*. Select the application you want to close, then tap *End Task*.

If you cannot force the application to close, or if closing and restarting the application does not fix the problem, try restarting the Trimble Geo7X. To restart the handheld, press the *Power/Home* button to go to the *Home* screen, then press the *Power/Home* button again to launch the *Power* menu. Tap *Restart*.

You do not lose any data when you perform a soft reset.

Performing a hard reset (cold boot)

Trimble recommends you do not perform a hard reset on a Trimble Geo7X controller. Perform a soft reset, and if that does not resolve the issues, contact your local Trimble reseller.

Getting rid of out of memory errors

Memory is managed automatically. If you run out of memory, close programs you no longer need. To do this, tap the Trimble button, select *Start Menu*, select [Settings / System / Task manager], select a program you no longer need and then tap *End task*.

Inserting and removing the battery

To insert the battery:

1. Slide the battery into the cavity with the label facing upward.
2. Push the battery in until it clicks into place.

To remove the battery:

1. Pinch the battery latches together until the battery is ejected.
2. Slide the battery out.

Trimble GeoXR controller

The Trimble GeoXR supports GNSS surveys (no conventional support).

The Trimble GeoXR supports the following key features:

Internal GNSS

The internal GNSS can be used for all survey operations including measure and stakeout.

The receiver will start automatically when an application is started.

The middle LED will flash blue when the receiver is starting/initializing and then flash orange when it is running. If the middle LED is red, there is no receiver firmware or there was an error starting the receiver.

Internal camera

The 5 megapixel camera can be used to capture and attach an image to a point.

Internal cellular modem

The integrated GSM/mobile internet modem enables wireless Internet connectivity.

Trimble GeoXR tips

- The Trimble GeoXR works only with the internal GNSS receiver. You cannot connect an external receiver to the Trimble GeoXR.
- The Trimble GeoXR cannot be used as a base.
- If you change the antenna during a survey, you are prompted to end the survey.
- Closing applications when not needed increases battery life.

Keys

The following table describes the General Survey software functions that are associated with the Trimble GeoXR controller keys.

Key	Function
	Camera button. When in Trimble Access, press and hold, and then release the camera button  to select the Trimble button.
	The [Left App] button and the [Right App] button on the Trimble GeoXR controller provide quick access to the <i>Esc</i> and <i>Enter</i> buttons respectively. You can customize the [Left App] button and the [Right App] button to perform your most used functions in the General Survey software. For details on how to set this up, see Customizing the App keys on a Slate/GeoXR/TSC2/TSC3 controller .

Status LEDs

Battery status

When the battery status light/led is:

- Green - battery charging is complete
- Orange - battery is charging
- Red and blinking slowly - battery level is critically low
- Red - battery fault

GNSS receiver status

When the receiver status light/led is:

- Green and blinking slowly - receiver is on and GNSS positions are available
- Orange and blinking fast - receiver is on but GNSS positions are not available

Wireless radio status

When the receiver status light/led is green and blinking fast one of the wireless connections (Wi-Fi, Bluetooth, or Phone) is turned on.

Handheld operation

Calibrating the touch screen

1. Tap the Trimble button, select *Start Menu* and then select [Settings / System / Screen].
2. Tap [Align Screen] and follow the prompts. If the calibration is successful, the [Settings] screen appears at the end of the calibration process. If the calibration was not successful, the target returns to the center of the screen and you must repeat the process.

You cannot disable the touch screen on the Trimble GeoXR.

Change the speaker volume

Tap the Trimble button, select *Start Menu* and then tap the sound icon at the top of the screen. From the panel of options, select the sound icon and then use the slider to increase or decrease the volume for the controller. Tap [Off] to mute.

Backlight

Tap the Trimble button, select *Start Menu* and then select [Settings / System / Backlight] to configure the backlight settings.

File Explorer

To start File Explorer, tap the Trimble button, select *Start Menu* and then tap [File Explorer].

You can also start File Explorer from the Trimble Access menu.

Folders and files that appear in File Explorer are those from Flash storage.

For more information, refer to the Windows Help provided on the controller.

Deleting files

Use *Jobs / Open job* to copy and delete job files. If you delete job files, any associated GNSS files are automatically deleted.

Use File Explorer to delete all other file types.

WARNING - Files deleted in File Explorer cannot be recovered.

Using the keypad to run programs

- To run a program from the [Start] menu:
Press **Ctrl** then **Esc** to display the [Start] menu, then use the arrow keys to select [Programs]. Press **Enter** to display a list of programs, then use the arrow keys to select the program that you want to run. Press **Enter** to run the program.
- If there is no icon or [Start] menu listing:
If there are no icons highlighted on the desktop, press the **Tab** key until one is selected, then use the arrow keys to select [My Computer]. In [My Computer], use the arrow keys to highlight the Disk folder, then press **Enter**. Use the arrow keys to locate the program you want to run (it may be located in a sub folder), then press **Enter** to run the program.

Resetting the handheld and troubleshooting

Performing a soft reset (warm boot)

You do not lose any data when you perform a soft reset.

To reset the Trimble GeoXR controller, hold down the **Power key** and then select **Reset**.

Performing a hard reset (cold boot)

Trimble recommends you do not perform a hard reset on a Trimble GeoXR controller. Perform a soft reset, and if that does not resolve the issues, contact your local Trimble reseller.

Getting rid of out of memory errors

Memory is managed automatically. If you run out of memory, close programs you no longer need. To do this, tap the Trimble button, select *Start Menu*, select [Settings / System / Task manager], select a program you no longer need and then tap *End task*.

Replacing the battery

1. Hold down the power button.
2. From the *Power* menu, select *Swap battery*.
3. Wait for the red battery light/led to go off.
4. Swap the battery and then press the power button to turn on the controller again.

Trimble Slate controller

The Trimble Slate controller supports the following key features:

Internal GPS

The internal GPS can be used to navigate to a point, to store a position, and for a GPS search. GPS search is automatically enabled but a connected GNSS receiver is always used in preference to the internal GPS.

Internal compass

The internal compass provides an aid to navigation.

Internal camera

The 8 megapixel camera can be used to capture and attach an image to a point.

Internal cellular modem

The integrated GSM/mobile internet modem enables wireless Internet connectivity.

Internal phone

The Trimble Slate controller includes a phone.

Trimble Slate controller tips

- By default, the [Left Softkey] button and the [Right Softkey] button are assigned to the *Left Softkey* and *Right Softkey* buttons respectively.
- Closing applications when not needed increases battery life.

Battery status LED

When the battery status light/led is:

- Green - battery charging is complete
- Orange - battery is charging
- Red and blinking slowly - battery level is critically low
- Red - low battery

Controller operation

Touch screen

Calibrating the touch screen

1. Tap the Windows button to access the *Start menu* and then select [Settings / System / Screen].
2. Tap [Align Screen] and follow the prompts. If the calibration is successful, the [Settings] screen appears at the end of the calibration process. If the calibration was not successful, the target returns to the center of the screen and you must repeat the process.

Disabling the touch screen

You cannot disable the touch screen on the Trimble Slate controller.

Changing the speaker volume

Tap the Windows button to access the *Start Menu* and then tap the sound icon at the top of the screen. From the panel of options, select the sound icon and then use the slider to increase or decrease the volume for the controller. Tap [Off] to mute.

Backlight

On a Trimble Slate controller, press the Windows button to access the *Start menu* and then select [Settings / System / Backlight] to configure the backlight settings.

File Explorer

To start File Explorer on a Trimble Slate controller, press the Windows button and from the *Start menu* tap [File Explorer].

You can also start File Explorer from the Trimble Access menu.

Folders and files that appear in File Explorer are those from Flash storage.

For more information, refer to the Windows Help provided on the controller.

Deleting files

Use *Jobs / Open job* to copy and delete job files. If you delete job files, any associated GNSS files are automatically deleted.

Use File Explorer to delete all other file types.

WARNING - Files deleted in File Explorer cannot be recovered.

Using the keypad to run programs

- To run a program from the [Start] menu:
Press **Ctrl** then **Esc** to display the [Start] menu, then use the arrow keys to select [Programs].
Press **Enter** to display a list of programs, then use the arrow keys to select the program that you want to run. Press **Enter** to run the program.

- If there is no icon or [Start] menu listing:

If there are no icons highlighted on the desktop, press the **Tab** key until one is selected, then use the arrow keys to select [My Computer]. In [My Computer], use the arrow keys to highlight the Disk folder, then press **Enter**. Use the arrow keys to locate the program you want to run (it may be located in a sub folder), then press **Enter** to run the program.

Resetting the controller and troubleshooting

Performing a soft reset (warm boot)

You do not lose any data when you perform a soft reset.

To reset the Trimble Slate controller, hold down the **Power key** and then select **Reset**.

Performing a hard reset (cold boot)

Trimble recommends you do not perform a hard reset on a Trimble Slate controller. Perform a soft reset, and if that does not resolve the issues, contact your local Trimble dealer.

Getting rid of out of memory errors

Memory is managed automatically. If you run out of memory, close programs you no longer need. To do this, tap the Windows button, to access the *Start Menu* and select [Settings / System / Task manager], select a program you no longer need and then tap *End task*.

Trimble Slate controller battery



You cannot remove the battery from the Trimble Slate controller. If the battery fails return the device to Trimble or an Authorized Service Provider to have the battery replaced.

Trimble S3 controller

Calibrating the touch screen

Open the Control Panel (**Ctrl, Esc, [Settings / Control Panel]**) then select the [Stylus] icon. In the [Stylus Properties] dialog select the [Calibration] >tab. Tap [Recalibrate] and follow the prompts, using the stylus to tap the target as it moves from the center of the screen, to each corner. If the calibration is successful, you are prompted to press **Enter** to accept the new settings. If the calibration was not successful, the target returns to the center of the screen and the process must be repeated.

Disabling the touch screen

To disable the Trimble S3 total station touch screen, press [Ctrl]+  key. This disables the screen, but not the keypad. The touch screen will remain disabled until you press [Ctrl]+  again or you reset the controller.

Using the keypad to run programs

For the Trimble S3 total station use the arrow keys to navigate to the icon for the program that you want to run. Press **Enter** to run the program.

Performing a hard reset (cold boot) on a Trimble S3 total station

After a hard reset, the operating system is reloaded into RAM from the Flash memory. Some software programs may also store shortcuts or database information in RAM; this is erased during a hard reset.

Press the power button and then tap the Options button in the *Power Key* dialog. Tap the Reset button in the *Power Option* dialog and then tap Yes in the *Restart* dialog to carry out the reset. This will shut down the instrument and then automatically restart it. Alternatively, you can tap the Shutdown button in the *Power Option* dialog and then confirm the shutdown. The instrument will shut down any running programs and return to the operating system desktop when you press the power button.

If you remove the battery, the instrument shuts down. When you replace the battery and turn on the power, the instrument restarts.

File storage

The RAM storage in the instrument is volatile and is shared between Storage memory and Program memory.

- Storage memory is required for such things as the Operating System, and installing programs.
- Program memory is required to run programs. When Program memory is low, programs may run slowly, become unresponsive, or even crash.

Flash memory is permanent, so data is not lost if the instrument loses power or after a hard reset. However, as with a computer hard disk, this storage may occasionally fail.

On the instrument, folders and files that appear in Explorer are those from Flash storage.

Changing the speaker volume

Open the Windows CE Control Panel (**Ctrl**, **Esc**, **S**, **C**) then select the Volume and Sounds icon. Use the slider to increase or decrease the volume. You can also use this dialog to turn on or off individual sounds, such as tapping the screen.

Backlight

On a Trimble S3 total station, tap [Start / Settings / Display / Backlight] to configure the backlight settings.

Trimble S3 total station stand-by mode

When you press the power key on the instrument to switch it off you get the option to place the instrument in stand-by mode. Stand-by mode shuts down the instrument but provides enough power to retain all settings and allow you to resume working from the same place in the software that you were before entering stand-by mode.

If you remove both batteries from the instrument, or they run completely flat, after replacing the batteries and switching on the instrument, the Microsoft Windows operating system will boot up and the General Survey software will start up automatically.



If you remove the battery from the instrument, or it runs completely flat, after replacing the battery and switching on the instrument, the Microsoft Windows operating system will boot up and you can run the General Survey software.

Trimble M3 total station

Keys

Trimble M3 total station keys



The following table describes the General Survey functions that are associated with the Trimble M3 total station keys.

Tap...	To...
	change between 123, ABC, and abc keyboard entry modes
	modify the action of the other key that you tap in conjunction
	access the <i>Trimble functions</i> screen

Trimble M3 total station face 2 keys

When taking measurements, the face 2 display shows the same measurement information as the view display button on the *Measure topo* and *Station setup* screens on face 1. This is typically horizontal angle, vertical angle and, after a measurement, the slope distance.

To scroll through the different views, press . Information such as current measurement status appears in the face 2 status line at the bottom of the display.



To take a measurement, press .  acts in the same manner as the Enter key on the face 1 keyboard so you can use it to start a measurement.

When a duplicate observation is encountered the face 2 display shows delta Horizontal angle, delta horizontal distance and delta vertical distance.







Note - Before you store the point, confirm the Store as action in the face 1 display.

The first button  on the face 2 screen controls the backlight and contrast settings.

To change the backlight:

1. Press .
2. Press  to switch the backlight on and off.
3. Press  to close the backlight control.

To change the contrast:



1. Press .
2. Press  to select the contrast icon.
3. Press  to display the contrast slider control.
4. Press  to increase the contrast, and press  to decrease the contrast.
5. Press  to close the contrast control.

Controller operation

Calibrating the touch screen

Open the Control Panel (**Ctrl, Esc, [Settings / Control Panel]**) then select the [Stylus] icon. In the [Stylus Properties] dialog select the [Calibration] tab. Tap [Recalibrate] and follow the prompts, using the stylus to tap the target as it moves from the center of the screen, to each corner. If the calibration is successful, you are prompted to press **Enter** to accept the new settings. If the calibration was not successful, the target returns to the center of the screen and the process must be repeated.

Disabling the touch screen

To disable the Trimble M3 total station touch screen, press [Ctrl]+  key. This disables the screen, but not the keypad. The touch screen will remain disabled until you press [Ctrl]+  again or you reset the controller.

Changing the speaker volume

Open the Windows CE Control Panel (**Ctrl, Esc, S, C**) then select the Volume and Sounds icon. Use the slider to increase or decrease the volume. You can also use this dialog to turn on or off individual sounds, such as tapping the screen.

Backlight

On a Trimble M3 total station, tap [Start / Settings / Display / Backlight] to configure the backlight settings.

Using the keypad to run programs

For the Trimble M3 total station use the arrow keys to navigate to the icon for the program that you want to run. Press **Enter** to run the program.

File storage

The RAM storage in the instrument is volatile and is shared between Storage memory and Program memory.

- Storage memory is required for such things as the Operating System, and installing programs.
- Program memory is required to run programs. When Program memory is low, programs may run slowly, become unresponsive, or even crash.

Flash memory is permanent, so data is not lost if the instrument loses power or after a hard reset. However, as with a computer hard disk, this storage may occasionally fail.

On the instrument, folders and files that appear in Explorer are those from Flash storage.

Performing a hard reset (cold boot) on a Trimble M3 total station

After a hard reset, the operating system is reloaded into RAM from the Flash memory. Some software programs may also store shortcuts or database information in RAM; this is erased during a hard reset.

Press the power button and tap the Options button on the *Power Key!* dialog presented. Tap the Reset button on the *Power Option* dialog then tap Yes on the *Restart* dialog to carry out the reset. This will shut down the instrument and then automatically restart it. You can also tap the Shutdown button on the *Power Option* dialog and then confirm the shutdown. The instrument will then do a full restart when the power button is pressed. Removing both batteries also results in an instrument shutdown and a full restart when the batteries are replaced and the instrument is switched on.

Controller keyboard functions

The controller provides several additional keyboard functions that you can access through the operating system.

- [Numeric and alphanumeric modes](#) (Trimble CU, Trimble S3 total station, and Trimble M3 total station only)
- [Input panel](#)
- [Transcriber](#)
- [Keyboard properties](#) (Repeat, Sticky keys, Key preview)

For more information on these functions, refer to the help. Tap *Start / Help*.

Numeric and alphanumeric modes

(Trimble CU, Trimble S3 total station, and Trimble M3 total station only)

Press the alpha key () to switch between numeric and alphanumeric modes. The current mode appears on the taskbar.

When you press the alpha key, the controller scrolls through 123 - ABC - abc.

The General Survey software automatically sets the mode to numeric for numeric fields. For fields that can be either alpha or numeric, the software inspects the field and then does one of the following.

If the fields contains the following character type...	the software sets the field to...
alpha	alpha
numeric	numeric
alpha and numeric	match the last character in the field

Input panel

The input panel looks and functions like a PC keyboard. Use it as an alternative to the controller keyboard for entering characters.

Trimble tablet

To access the input panel, do one of the following:

- Tap once in the field requiring text and then tap the input icon.
- Press the **(Fn + F1)** button

The keyboard accessed by these methods are slightly different. Use the keyboard that best suits your needs.

TSC3

To open or close the input panel, press and hold **Ctrl** and then press **7**.

Tip - If you do not find the default predictive text functionality useful, you can disable it. To do this, tap [Windows / Settings / Personal / Input], select the [Word Completion] tab and then clear the *Suggest words when entering text* option.

TSC2

To access the input panel through the taskbar icon () on a TSC2 controller that is running:

- the General Survey software: Press and hold **Ctrl**, press **7** to display the input panel icon and then tap the icon.
To close, tap the icon again.
- a program other than the General Survey software: Tap the icon.
To close, tap the icon again.

Trimble CU

To access the input panel through:



- the taskbar icon () , tap the icon and then select the keyboard to display. To close, tap the icon again and then select [Hide Input Panel].
- a keyboard shortcut, press and hold **Ctrl** and then press **7**. To close, press and hold **Ctrl** and then press **7** again.

Trimble S3 total station and Trimble M3 total station

To access the input panel through:

- the taskbar icon () , tap the icon and then select the keyboard to display. To close, tap the icon again and then select [Hide Input Panel].
- a keyboard shortcut, press and hold **Ctrl** and then press **7**. To close, press and hold **Ctrl** and then press **7** again.

Trimble Geo7X

The keyboard icon () automatically appears in the tile bar of any application requiring text or numeric input. To display the keyboard, tap () or tap a text box in the application. To hide the keyboard, tap () again.

Tip - If you do not find the default predictive text function useful, you can disable it. To do this, tap the Trimble button, select *Start Menu*, select [Settings / Personal / Input], select the [Word Completion] tab and then clear the *Suggest words when entering text* option.

Trimble GeoXR

The Trimble GeoXR controller does not have a taskbar icon for the input panel.

Tip - If you do not find the default predictive text function useful, you can disable it. To do this, tap the Trimble button, select *Start Menu*, select [Settings / Personal / Input], select the [Word Completion] tab and then clear the *Suggest words when entering text* option.

Trimble Slate controller

The Trimble Slate controller does not have a taskbar icon for the input panel.

Transcriber

Transcriber recognizes characters that you write on the controller screen with the stylus.

Trimble tablet

To enable the transcriber, access the [input panel](#) by tapping once in the field requiring text and then tap the input icon. and then select the transcriber icon () .

To further configure transcriber options, access the input panel and then tap [Tools / Options]. Alternatively, tap the Trimble button to access the *Start menu*, and then tap [Control Panel / Tablet PC Settings - Other] and select *Go to Pen and Touch*.

TSC3

The TSC3 controller does not support the transcriber.

TSC2

To enable the transcriber for a TSC2 controller that is running the General Survey software, press and hold **Ctrl** and then press **7**. Tap the icon that appears at the center bottom of the screen, tap the arrow that appears beside it and then select [Transcriber] from the menu.

To start using the Transcriber, tap the Transcriber icon on the taskbar . The icon appears with a white background.

To stop using Transcriber, tap the icon on the task bar. The icon background color changes. To start using again, tap the icon.

Note - When Transcriber is enabled, you need to tap and briefly hold screen buttons or icons to activate them. There is a slight delay while Transcriber determines if you are using the stylus to write with.

Trimble CU

To enable the transcriber, tap [Start / Programs / Accessories / Transcriber].

The Transcriber icon on the taskbar  appears with a grey background.

To stop using Transcriber, tap the icon on the task bar. The icon background color changes. To start using again, tap the icon.

Note - When Transcriber is enabled, you need to tap and briefly hold screen buttons or icons to activate them. There is a slight delay while Transcriber determines if you are using the stylus to write with.

Trimble S3 total station and Trimble M3 total station

Tap [Start / Programs / Accessories / Transcriber].

The Transcriber Input Panel appears on screen and the taskbar icon changes to .

To stop using Transcriber, tap the icon on the task bar and select [Hide Input Panel].

Note - When Transcriber is enabled, you need to tap and briefly hold screen buttons or icons to activate them. There is a slight delay while Transcriber determines if you are using the stylus to write with.

Trimble GeoXR and Geo7X controller

The GeoXR and Geo7X controllers do not support the transcriber.

Trimble Slate controller

The Trimble Slate controller does not support the transcriber.

Keyboard properties

To set the following:

Repeat

Repeat delay sets the time from when you first press a key to when the character starts repeating. Repeat rate sets the speed at which the character repeats.

To access the delay and repeat configuration:

- On a Trimble tablet, tap the Trimble button to access the *Start menu*, and then tap [Control Panel / Keyboard].

- On a TSC3 controller, press the Windows button to access the *Start* menu and then tap [Setting / Personal / Buttons - Up/Down control].
- On a TSC2 controller, press the Windows button and tap [Settings / Buttons - Up/Down Control].
- On a Geo7X/GeoXR controller, tap the Trimble button, select *Start Menu* and then select [Setting / Personal / Buttons / Up/Down Control].
- On a Trimble Slate controller, press the Windows button to access the *Start* menu and then tap [Setting / Personal / Buttons - Up/Down control].

Sticky keys

(Trimble CU, TSC2 only)

Use this to access a hotkey sequence without having to press and hold a modifier key (**Alt**, **Ctrl**, or **Shift**) while you press the hotkey.

To access the sticky key configuration:

- On a Trimble CU controller, Trimble S3 total station, or Trimble M3 total station, tap [Start / Settings / Control panel / Keyboard].
- On a TSC2 controller, press the Windows button and tap [Settings / Buttons - Keyboard Options].

If Sticky keys is enabled, when you press a modifier key, that key 'sticks' until you press it again. For example, on the Trimble CU, use sticky keys to copy text (**Ctrl+C**) and paste text (**Ctrl+V**).

- Sticky keys enabled: Press **Ctrl**, and then press **8** three times (C). Press **Ctrl** and then press **2** three times (V).
- Sticky keys disabled: Press and hold **Ctrl** while you press **8** three times (C). Press and hold **Ctrl** while you press **2** three times (V).

Sticky Ctrl

(Trimble S3 total station and Trimble M3 total station only)

Use this to access a hotkey sequence without having to press and hold the **Ctrl** key while you press the hotkey.

If Sticky Ctrl is enabled, when you press the Ctrl key, it 'sticks' until you press it again. For example, use Sticky Ctrl to copy text (**Ctrl+C**) and paste text (**Ctrl+V**).

- Sticky Ctrl enabled: Press **Ctrl**, and then press **8** three time (C). Press **Ctrl** and then press **2** three times (V).
- Sticky Ctrl disabled: Press and hold **Ctrl** while you press **8** three times (C). Press and hold **Ctrl** while you press **2** three times (V).

Key preview

(Trimble CU, Trimble S3 total station, and Trimble M3 total station only)

When the controller is in alpha mode, a popup window shows the active character. For example, if you press **8** four times, the key preview shows, in succession, a, b, c, 8.

Note - You do not need to wait for the previewed character to be accepted before you press another key, for example **Enter** or another character. When you press another key, the controller accepts the character that is currently in the preview window. This function enables you to enter characters faster.

Alternatively, shorten the key preview to speed up alpha character entry.

For more information on these functions, refer to the help. Tap *Start / Help*.

Printing from a P4T mobile Bluetooth printer

You can print directly from controllers in the field to the Zebra P4T mobile printer. The mobile P4T printer prints barcode labels and documents up to 4" wide that are designed for outdoor use.

The Zebra P4T printer is available in several different configurations. Trimble recommends purchasing a model that has Bluetooth wireless technology. The P4T includes a rechargeable battery, but may not include an AC adapter. Printer ribbon and paper/labels must also be purchased separately. Check with your supplier regarding consumables and a suitable charging system to meet your needs.

From the Stakeout *View before storage* screen, you can print the stakeout details displayed. This is particularly useful for creating labels that can be affixed to the stake.

Setting up and using the P4T printer

1. Turn on the P4T Bluetooth printer.
2. From the Trimble Access screen, select *Settings / Bluetooth* and then tap *Config* and scan for the printer. The printer name displayed is the serial number displayed on the back of the printer. When setting up the Bluetooth pairing you should not need to enter a passcode, or enable the *Serial Port* check box.

If required, rename the printer and set up a passcode using the Zebra Setup Utilities (<https://www.zebra.com/us/en/support-downloads/mobile/p4t.html>).

3. Select the printer in the *Connect to printer* field and tap *Accept*. The *Print* button is now available in the Stakeout *View before storage* screen.

To print, turn on the printer and tap *Print*. When you tap *Print* the controller connects to the P4T using the Bluetooth wireless connection you have set up, and then prints the label.

P4T printer label layout

Printer layout is user-configurable through *.lbl files. The .lbl file defines the information to print including additional items such as company logos, static text, and date and time. The .lbl file also defines the appearance of the printed information, such as font size and the position of logos.

The deltas shown in the Stakeout *View before storage* screen depend on the entity being staked, options configured and the selected *Staked deltas format* selected. A display format must have a print style associated with it for the *Print* softkey to be available. Because of this complexity, Trimble has developed printer formats only for point, line and arc stakeout when the selected *Staked deltas format* is the "Default" format. To print from any of the other staked delta formats you must define your own print format .lbl file.

For more information, go to www.trimble.com/Survey/Trimble-Access-IS.aspx and click *Downloads*.

Entering quadrant bearings

1. Make sure the system units are quadrant bearings. For more information, see [Units](#).
2. Enter the bearing in any *Bearing* field.
3. Select NE, NW, SE, or SW from the popup list. The quadrant bearing is inserted in the field.

Example

To enter the quadrant bearing N25° 30' 30"E in a bearing field:

- Key in **25.3030** .
- Select NE from the popup list.

Calculator

To perform a calculation from within a dialog field:

1. Select Calculator from the pop-up menu.
2. Enter the numbers and functions.
3. Tap = to calculate the result.
4. Tap Accept to return the result to the field.

When accessing the calculator with the pop-up arrow, if the numeric field already contained a number that number is automatically pasted into the calculator. At the end of the calculator operations the last solution is pasted back into the numeric field when *Accept* is selected.

Tip - To use the calculator at any time, select *Cogo / Calculator* from the main General Survey menu.

Troubleshooting

[Bluetooth wireless technology issues](#)

[Communication issues](#)

[Conventional survey issues](#)

[GNSS survey issues](#)

[Job data issues](#)

[Tilt issues](#)

Bluetooth wireless technology issues

The message "Connection failed" appears when you try to connect to a Bluetooth cellular modem.

Some cellular modems have different Bluetooth modes. If the mode is set to [Off] or [Automatic], a "Connection failed" message may appear. For a successful Bluetooth connection, set the mode to [On].

The message "Hardware Error 1" appears when you tap [Scan] in the [Bluetooth Device Properties] applet.

Clear, then re-select the [Enable Bluetooth] check box.

Bluetooth controller does not always find all the Bluetooth devices within the specified range

A Bluetooth scan cannot always find other Bluetooth devices during the scan if there is another Bluetooth device scanning in the same area. If the device you are looking for is not found during a scan, wait a minute, and then scan again.

Bluetooth device not registered

If this message appears when you start an internet RTK survey, you have selected *Internet connection* as your rover radio when you are using a Trimble Internal mobile internet module. You must select *Trimble receiver internal* as your rover radio and set the method to *Mobile internet*.

Bluetooth scan finds a [(null)] device

Sometimes during a Bluetooth scan, a Bluetooth device within range is found, but not the device name. In this case, a [(null)] name is returned. Re-scan for the device until the correct name is returned.

Bluetooth operating range difficulties

Bluetooth has an operating range of 10 meters (~33 feet).

Bluetooth [Scan] cannot find the Trimble receiver

If the Bluetooth connection between the receiver and a Trimble CU has been disrupted, or if the receiver is already connected to another Bluetooth device, [Scan] may fail to find the receiver. Switch off the receiver, then switch it on again. Enable the [Enable Bluetooth] check box if it has been cleared and do another scan. If the [Scan] still cannot find the receiver, perform a warm boot on the receiver. Do another scan.

Intermittent communication errors when using Bluetooth

Make sure that your body does not block the line-of-sight between the two devices that are communicating with Bluetooth.

Communication issues

Modem is not responding

This message may appear after a *Connecting to modem* dialog has to be canceled because it goes on indefinitely. If this happens, power cycle the modem.

If you see the "Modem is not responding" message when connecting to an Enfora GSM/mobile internet card, you may need to set the baud rate. To do this:

1. On the controller, tap [Start / Settings / Connections].
2. Tap the [Connections] icon and then select [Manage existing connections] under [My ISP].
3. Select the connection name for the Enfora card that you created earlier, and tap [Edit].
4. Tap [Next] twice and then tap [Advanced].
5. Set the [Baud rate] to 115200.
6. Tap [Ok] and [Finish] as required to exit the Enfora configuration.

No communication between instrument and the General Survey software

Check the cables, connections and switches. Also check the power source to the receiver or conventional instrument.

Note - Make sure that you have selected an appropriate survey style.

Not receiving radio

Check that all radio cables are connected to the correct ports and that the radio is switched on.

Check that the radios are configured correctly in the Survey Style.

Check that there are no obstructions (for example, trees or buildings). If there are, move to a place where the radio signals will not be obstructed.

Check that the base radio is switched on.

Conventional survey issues

Conventional instrument behaving erratically

Set the *HA VA status rate* to Never if the instrument screen blinks erratically or has problems maintaining communication with the General Survey software. Some instruments cannot support a high status update rate.

Conventional instrument will not connect

Always select the correct survey style in the General Survey software before connecting the controller to a conventional instrument. Otherwise, they may fail to connect. If this occurs, reset the conventional instrument by switching it off and then on, and then try to connect again.

GNSS survey issues

"Error: Outside usage region" message appears when starting a survey

If this message appears, the connected receiver is unable to be used in the current geographic location. For more information, contact your Trimble distributor.

"Receiver supports Location RTK precisions, set Style tolerances accordingly" message appears when starting an RTK survey

If this message appears, the connected receiver supports Location RTK, which limits the precision of the RTK solution in the receiver. Tap *Yes* to change the survey style precision settings to match the Location RTK precision limit of the receiver. If the survey style is already set to a higher precision than the Location RTK precision limit of the receiver, then the survey style is not updated.

When the receiver has Location RTK enabled, the status line shows RTK: Float. You cannot store fixed positions when Location RTK is enabled in the receiver.

Tap *No* to keep the current survey style precision settings.

Initialization lost because of high RMS

The receiver has discarded the current initialization because the measurement RMS has stayed too long above an internal cut-off value. This may be caused by too much pole movement when static, by a very bad environment, or by incorrect initialization with pre version 4.00 receiver firmware. Check two or three points measured with the initialization that was lost. To do this, reinitialize in a good environment and then remeasure the points. If the remeasurements agree within RTK tolerances, you can be confident that the initialization was correct and that a bad environment caused the loss of initialization.

"Cannot start streamed corrections" message during an RTK survey

Make sure that the Internet connection you are using works outside of General Survey. Connect to the Internet, browse one or two websites, and use Google.com or similar. Leave that connection open and start a survey with General Survey. If the survey still fails to start correctly, there may be a problem with the IP addresses or port numbers in the style, or the base station providing the data may not be operational.

"No Base Data" during an RTK survey

If you start an RTK survey and the *No base data* message appears, check the broadcast format, the initialization string for your modem, the IP address, and the port number of the base.

"No Carrier" message when dialing up an RTK base

This message means that the base is not answering, or that the rover cannot get a dial tone. Call the base manually to make sure that it answers, and is not going to a voicemail system. Check that the rover has enough money on its account.

"Warning: Base coordinates different. Coordinates of base point <Point name> in job differ from received coordinates" message when receiving RTK corrections

This message appears when the point name of the base received from the base data link is the same as a point name already in the job file, and the two points have different WGS84 coordinates. If you are certain that the base is set up on the same point as the one already in the job database, then tap *Job* to use the job database coordinates for the point. If the base is in a different location to the point already in the job database, then you must change the point name. Tap *Received* to use the coordinates received from the data link and rename the new base point. Tap *Cancel* to cancel the survey.

Note - *If you have an RTX-RTK offset in the job, you will not be given the choice of using the received coordinates for the base. Correct use of the offset relies on all RTK being in the same terms, and if the point with different coordinates to those already in the job comes from the base this could mean the RTK is not in the same terms.*

No data recorded in receiver

Check the Base and Rover options in the survey style. Is the logging device set to Receiver? Is the antenna connected? Is power connected?

Receiver does not turn on

Check the cables, connections, and switches. Also check the power source.

RTK survey will not work

Check that you have selected an RTK Survey Style. Check that it is configured for RTK in the *Type* field in both the Base and Rover options. Check that the antenna is configured correctly in the *Antenna Type* field in Base and Rover options. Check that the radio is working and that it has been configured correctly.

RTK precisions are too high

If the RTK survey is initialized, remain stationary on the point for a while and wait for the precisions to decrease. If the RTK survey is not initialized, move to a better environment or try a known point initialization.

Satellite/s not being tracked

Check that there are no obstructions - look at the azimuth and elevation of the SV in the *GNSS / Satellites* screen. Check the GNSS antenna connections. Check the elevation mask setting. Check that the satellite is not disabled - tap *Info* in the *Satellites* screen. Are there any transmitting antennas nearby? If there are, reposition the GNSS antenna.

OmniSTAR not converging

If the OmniSTAR solution is not converging as expected, you may need to wait longer for this to happen. If you measured an OmniSTAR offset when the precision estimates were high, or chose to use an offset with high precision estimates, then the OmniSTAR solution may not converge as expected.

Job data issues

No coordinates in Review

Check the [Coordinate view](#) setting. To change the coordinate view settings, do one of the following:

- From the *Jobs* menu, tap *Review job*. Open the point record and then tap *Options*.
- From the *Key in* menu, tap *Points* and then tap *Options*.

To see grid coordinates in review, this setting must be grid. Also, to display grid coordinates, a projection and datum transformation must be defined.

In conventional surveys, check that the instrument and/or backsight point has been coordinated.

In conventional surveys, an observation is displayed with null coordinates until the observation to the backsight is stored.

No grid coordinates

Check that a projection and datum transformation have been defined. Also check that the [Coordinate view](#) setting is Grid.

To change the coordinate view settings, do one of the following:

- From the *Jobs* menu, tap *Review job*. Open the point record and then tap *Options*.
- From the *Key in* menu, tap *Points* and then tap *Options*.

Tilt issues

Excess tilt

Adjust the pole angle to be within the tilt tolerance. Alternatively, increase the tilt tolerance. Only applicable when using an instrument with a tilt sensor.

If you choose to continue and store a point outside the tilt tolerance, a warning record is associated with the point.

Jobs menu

Use this menu to view and manage jobs, and transfer data between the office computer and external devices.

For more information, see:

[New job](#)

[Open job](#)

[Review job](#)

[Point manager](#)

[QC Graph](#)

[Map](#)

[Properties of job](#)

Copy between jobs

Import/Export

Job repair wizard

The Job repair wizard runs when General Survey detects damage in the job file. You can cancel the wizard at any point or go back to any previous step.

The wizard retrieves job data up to the point of the damage, discards anything beyond this point, and informs you of the time and date of the last good item in the job.

As a safety measure, the wizard can make a copy of the job before anything is discarded. Before proceeding with the copy, check that the file system has enough space for a copy of the entire job.

Once the repair is completed, use *Jobs / Review job* to check what (if anything) has been discarded from the end of the job. Because the job is stored in chronological order, anything discarded is timed later than the last good record reported by the wizard.

Be aware that discarded data may include changes made to the job such as deletions (the item may no longer be deleted), changes to antenna or target heights, coordinate systems, and new items such as points, observations, and lines.

Damage to Job files may be caused by a hardware problem, a failure to properly shut down the General Survey program, or an unexpected power failure due to a flat battery. When the Job wizard reports a problem, review the controller's operating procedure, and/or check the hardware. If you repeatedly experience corruption problems, there may be a fault in your controller hardware. For more information, contact your local Trimble reseller.

Job Operations

Managing jobs

A job can contain several different surveys. Select a job before you measure any points or make any calculations.

Jobs can be saved in your <username> folder, or in a [project folder](#) in the <username> folder.

Jobs that are defined in one Trimble Access application, for example, General Survey can be used in another application, for example, Roads.

The easiest way to create a job is to create a job from a template. A template is a collection of job properties. You can create a template from an existing job. For more information on creating templates, see [Templates](#).

Creating a job

1. From the main menu, tap *Jobs / New job*.
2. Enter a name for the new job.
3. Tap  to create a new [project folder](#) or select an existing folder.
4. Select a [Template](#) from the drop down list. If the template was created from a job that you have previously set up, all of the job properties are copied from the template.
5. Define/edit the following properties of the job, as required:
 - a. Tap the *Coord. sys.* button and choose a [coordinate system](#) for the job. Tap *Next*.
 - b. Configure the coordinate system settings required for the job and tap *Store*.
 - c. Tap the [Units](#) button to specify the units and various other settings for the job. Tap *Accept*.
 - d. Tap the [Linked files](#) button to select a linked file(s) for the job. Tap *Accept*.
 - e. Tap the [Active map](#) button to select an active map file(s) for the job. Tap *Accept*.
 - f. Tap the [Feature library](#) button to associate a feature library with the job. Tap *Accept*.
 - g. Tap the [Cogo settings](#) button to set the cogo settings for the job. Tap *Accept*.
 - h. Tap the [Additional settings](#) button to set additional settings for the job. Tap *Accept*.
 - i. Tap the [Media file](#) button to set the media settings for the job. Tap *Accept*.
 - j. Optionally, tap the *Page down* button to enter *Reference*, *Description* and *Operator* details, and any *Notes*.

6. Tap *Accept* to save the job.

Opening a job

1. From the main menu, tap *Jobs / Open job*.
2. Tap  to expand a folder and display the files within the folder.
3. Tap the job name, or highlight the job name and tap *OK*.
The job name appears in the title area of the main menu.

Deleting a job

1. From the main menu, tap *Jobs / Open job*.
2. Tap  to expand a folder and display the files within the folder.
If the job you want to delete is not highlighted, use the arrow keys to highlight it, or tap and hold it with the stylus.



Note - If you tap with the stylus without holding, the job that you highlight opens automatically.

3. Tap  to delete the file.
4. Tap *Yes* to confirm deletion, or *No* to cancel.

Note - When you delete a job, all associated files (for example, *.t02, *.tsf *.jpg) are automatically deleted.

Tip - You can also use [Fn + Del] on the TSC2/TSC3 controller or [Ctrl + Del] on the Trimble CU/Trimble tablet to delete jobs from the *File / Open* dialog.

Copying a job

1. From the main menu, tap *Jobs / Open job*.
2. Highlight the name of the job to be copied and tap .
3. Browse and highlight the folder to paste the file into and tap .

Tip - You can also use *Windows/File Explorer* to copy, rename, or delete a file.

Note - When you copy a job to another folder, associated files (for example, *.t02, *.tsf *.jpg) are not automatically copied.

Copying data between jobs

1. From the main menu, tap *Jobs / Copy between jobs*.
2. Browse to and select the job to be copied from.
3. Select the job that the data will be copied to.
4. Select the type of data to be copied and select whether duplicate points should be copied.
5. Tap *Accept*.

File management

All project files are saved to the selected **project folder**, or to auto-generated subfolders inside the selected project folder. The default project folder is the Trimble Data **<username>** folder. The <username> folder is created the first time you log in to the Trimble Access application.

If required, you can create individual project folders inside the <username> folder. Auto-generated folders are then created as required, inside the <username>\<projectname> folder.

Different types of files are stored in different folders on the controller:

Folder	File type	Examples
\Trimble Data\System Files	System	Custom export style sheets (.xsl), Feature libraries (.fxl), Geoid (.ggf), and Survey styles (.sty)
<project> folder: \Trimble Data\ <username> or \Trimble Data\ <username> \<projectname>	Project	Jobs (.job), Control files (.csv), Maps (.dxf, .str, .shp), Alignments (.rxl, .txl)
<project>\<jobname> Files	Project	Image and media files (.jpg), Scan files (.tsf), GNSS data files (.t01, .t02), Broadcast RTCM transformation files (.rtd)
<project>\<jobname> Files\Original Files	Project	Original image files (.jpg)
<project>\<jobname> Files\V10 Panorama Files	Project	V10 image files, including calibration files (.jpg)
<project>\Export	Exported	Htm reports (.htm) and Comma delimited files (.csv)

All system type files are stored in the System Files folder. System files cannot be accessed if they reside in another folder.

When you create files using *Export fixed format files* or *Export custom format files*, you can save the new format files to an existing folder on the controller, or create a new one. The default folder is the Export folder inside the current project folder. If you change the project folder, the system creates an export folder inside the new project folder, and gives it the same name as the previous export folder. Tap  to select an existing folder or create a new one.

The file extension on the office computer, the file extension on the controller (which changes if the file is converted during transfer), the file description, and the location the file is saved to, are as follows.

File type:			Folder the file is saved to:		
Computer file extension	Controller file extension	Description	System Files	<project >	<jobname> Files
.dc	.job	General Survey job files	-	*	-
.csv	.csv	Comma Delimited (CSV) files	-	* 1	-
.txt	.txt	Comma Delimited (TXT) files	-	* 1	-
.dtx	.dtm	Digital Terrain Model files	-	*	-
.ttm	.ttm	Triangulated Terrain Model files	-	*	-
.fxl	.fxl	Feature Library files (TBC)	*	-	-
.fcl	.fal	Feature and Attribute Library files (TGO)	*	-	-
.sty	.sty	Survey Style files	*	-	-
.ddf	.fal	Data Dictionary files	*	-	-
.ggf	.ggf	Geoid Grid files	*	-	-
.cdg	.cdg	Combined Datum Grid files	*	-	-
.pjpg	.pjpg	Projection grid files	*	-	-
.sgf	.sgf	Shift grid files	*	-	-
.pgf	.pgf	UK National Grid files	*	-	-
.rtd	.rtd	Broadcast RTCM transformation files	*	-	-
.dxf	.dxf	Map files	-	* 1	-
.str	.str	Surpac files	-	* 1	-
.shp	.shp	ESRI map Shapefiles	-	*	-
.ini	.dat	Antenna files	*	-	-
.lng	.lng	Language files	* 2	* 2	-
.wav	.wav	Sound files	* 2	* 2	-
.t01 .t02	.t01 .t02	GNSS data files	-	-	*
.crd .inp .mos	.crd .inp .mos	GENIO road files	-	*	-
.xml	.xml	LandXML road files or XML	-	*	-

File type:			Folder the file is saved to:		
Computer file extension	Controller file extension	Description	System Files	<project >	<jobname> Files
Documents					
.xml	.xml	GNSS Contacts file [GNSSContacts.xml]	*	-	-
.jxl	.jxl	JobXML files	-	* 1	-
.ixl	.ixl	Custom ASCII Import file definitions	*	-	-
.xsl	.xsl	XSLT Custom ASCII Export Stylesheet files	* 3	-	-
.sss	.sss	XLST Custom Stakeout Stylesheet files	* 3	-	-
.mcd	.mcd	Measure Codes Database files	*	-	-
.dc	.rxl	Trimble road file	-	*	-
.rxl	.rxl	Alignment files	-	*	-
.txl	.txl	Tunnel file	-	*	-
.csd .csw	.csd	Coordinate System Database files	*	-	-
.jpg	.jpg	Image files	-	-	* 4
.bmp	.bmp	Screendump files	-	* 5	-
.tsf	.tsf	Scan files	-	-	*
.scprf	.scprf	Trimble Access profile file	*	-	-

Notes

1. *.csv, .txt and JobXML (.jxl) files that are transferred to the controller should be transferred to the project folder. Files that are exported on the controller are stored in the Export folder inside the project folder. To link an exported .csv file, copy the file into the project folder using Explorer.*
2. *Language files (.lng) and Sound files (.wav) are stored in the appropriate language folder.*
3. *Stakeout stylesheet files (.sss) and Custom Export stylesheet files (.xsl) can be located in both the language folder or System Files. Translated Stakeout stylesheet files and translated Custom Export stylesheet files are typically stored in the appropriate language folder.*
4. *When you [draw](#) on or [annotate](#) an image and select the Save original image option, the original image is saved to the <project>\<jobname> Files folder.*

5. *Screendump files save an image of the current screen. To create a screendump, press the **Ctrl + S** keys on the controller, or tap the **Ctrl + S** keys on the onscreen keyboard.*
6. *To create new project folders or move files from one folder to another, use the General Survey software or Windows Explorer.*

Reviewing and editing job properties

Use this menu to configure settings for the current job.

For more information, see:

[Coordinate system](#)

[Units](#)

[Linked files](#)

[Active map files](#)

[Feature library](#)

[Cogo settings](#)

[Additional settings](#)

[Media file](#)

Each button displays the current settings. When you create a new job, settings from the previous job are used as the defaults. Tap a button to change the settings.

Tap *Accept* to save any changes.

Tip To set default values for the *Reference*, *Description*, *Operator*, or *Notes* fields, or to set these fields as "required" so that values must be entered in these fields, copy the JobDetails.scrpf file in the Trimble Data \ [System] folder to an office computer and modify the file using a text editor. Then copy the file to the controller. The settings in the JobDetails.scrpf file are read each time the Trimble Access application is run. For more information on editing the file, refer to the notes provided at the top of the JobDetails.scrpf file.

Reviewing data stored in the job

To see the records stored in the job database:

1. From the main menu, tap *Jobs / Review job*.
2. Use the arrow keys, stylus, or softkeys to navigate the database.

Tips

- To move to the end of the database quickly, highlight the first record and press the up arrow key.
 - To highlight a field without selecting it, tap and hold briefly with the stylus.
3. To see more information about an item, tap the record. Certain fields, for example, *Code* and *Antenna height*, can be edited.

Notes

- For points measured using a GNSS receiver with an integrated tilt sensor, the following records are available:
 - *Warnings:* The Warnings section shows which warnings were given during the occupation when the point was being measured.
 - *Conditions:* The Conditions at storage section shows the error conditions that were present at the time the point was stored.
- For points that have panoramas captured with them, tap the photo station record to view the Panorama screen. When reviewing a panorama captured using a Trimble total station with VISION technology and with the *HDR option enabled*, the image first shown in the review screen is the image captured using the middle, or normal, exposure. Tap >Over to view the over-exposed image. Tap >Under to view the under-exposed image. Alternatively, tap the arrow softkeys or the arrow controller keys to cycle through all of the images. Panoramas captured using the *V10 imaging rover with the HDR option enabled* only show one image in the Review screen as the HDR processing is done in the camera head immediately after image capture.
- Panoramas that you delete are permanently deleted.
- Offset points that are stored as coordinates are not updated when you change an antenna or target height record in the database. In addition, a change in antenna height does not affect any postprocessed points that will be processed using the Trimble Business Center software.
 Verify the antenna or target height information when you transfer the data to the office computer or transfer postprocessed points directly from the receiver to the office software.
 When you change an antenna or target height record in the database, stakeout deltas, Cogo points, averaged points, calibrations, resections, and traverse results are not automatically updated. Re-observe staked out points, and re-calculate Cogo points, averaged points, calibrations, resections, and traverses.
- To search for a particular item, tap Search and select an option.

Tip - To review features from the Map screen, select the required feature(s), tap and hold on the screen and choose Review from the shortcut menu.

Changing the coordinate view display in Review job

1. From the main menu, tap *Jobs / Review job*.
2. Use the arrow keys, stylus, or softkeys to navigate the database.
3. Do one of the following:
 - Tap + to expand the point tree list.
 To change the coordinate display, tap one of the ordinates and then select the appropriate *coordinate view* from the list.
 - Tap the point name to view details about the point.
 To change the *coordinate view*, tap *Options*.
 If you selected *Grid (local)*, select the *Transformation for grid (local) display* name. This transformation transforms the grid coordinates to Grid (local) coordinates using the

selected transformation.

Unless the transformation selected here is the same as the input transformation, the Grid (local) coordinates shown will not match the original Grid (local) coordinates. To see the original Grid (local) coordinates, set the Coordinate view to *As Stored*.

Transformation (as stored) is displayed when reviewing Grid (local) and the *Coordinate view* is set to *As Stored*.

Transformation (display) is displayed when reviewing Grid (local) and the *Coordinate view* is set to *Grid (local)*.

Tap Stakeout beneath the corresponding Point name to reveal the as-staked delta information.

Occupation warnings

Each point measurement in *Review* records if excess movement, excess tilt, and poor precision tolerance warnings were displayed during the occupation of the point, and if any of those tolerances were exceeded at the critical time when the point was stored.

To view the occupation warnings records, go to page 4 of the point record. The *Warnings* section shows the warnings that were given during the point measurement. Excess tilt, excess movement, and poor precision warnings that were displayed during the time the point was being measured show *Yes*, those that were not displayed show *No*. On page 5 the *Conditions at storage* section shows if excess movement, excess tilt or poor precision warnings were being displayed at the time the point was accepted and stored. The conditions at storage have a major impact on the measured coordinates of the point.

Viewing and editing media files

To view a media file:

1. Highlight a media file record.
 - Tip** - To highlight a field without selecting it, tap and hold briefly with the stylus.
2. Tap *Details*. The image appears.
3. To change the *Link to* method and the name of any linked point, tap the *Link* softkey.
 - Tip** - Select *None* to remove the link to the job or a point. The media file is not deleted from the user name folder.
 - Note** – If the image includes an information panel and you edit values defining the measured point for the image such as the code and descriptions, the *information panel* is not updated.
4. To mark up an image, tap *Draw*.

Inserting notes

To store a note in the database:

1. Highlight a record.
2. Tap *Note*. The *Note* screen that appears displays the date and time that the current record was created.

3. Enter the note and then tap *Accept*. The note is stored with the current record. In *Review job*, the note appears below the record with the note icon.

Editing target/antenna records

Editing target/antenna records using Review job

Select *Review job* to edit existing antenna or target height records. These edits change the antenna or target height for all observations using that antenna or target height.

To edit a target/antenna record:

1. Tap the target/antenna record. The current target (conventional survey) or antenna (GNSS survey) details appear.
2. Enter the new details and then tap *Accept*.
The current record is updated with the new details, which apply to all subsequent observations using that record.
A note with a timestamp is attached to the record. This note documents the old details, including when the changes were made.

Editing target/antenna records using Point manager

Use [Point manager](#) to easily change the target or antenna height of a single observation or any number of observations.

Editing codes

Editing codes using Review job

If you have only a single code to edit, you can use *Review job*.

To edit a code:

1. From the main menu, tap *Jobs / Review job*.
2. Tap the observation record that contains the code you want to edit.
3. Change the code and then tap *Accept* to store the changes.

The Note stored with the observation is a record of the old code and the date and time it was modified.

Editing codes using Point Manager

You can use *Point manager* to edit single or multiple codes. When you edit multiple codes, the *Point manager* is easier to use than *Review job*.

For more information, see [Point manager](#).

Editing point names and point coordinates using Point Manager

You can use *Point manager* to edit point names or point coordinates. You cannot edit point names and point coordinates using *Review job*.

Deleted points, lines, and arcs



A deleted point, line, or arc is not used in calculations, but it is still in the database. Deleting points, lines, or arcs does not make a job file smaller.

When you transfer a file that contains deleted points, the deleted points are not transferred to the office software. If you transfer a file using the Trimble Data Transfer utility, however, the deleted points are recorded in the Data Collector (.dc) file. They have a classification of Deleted.

Some points, such as continuous offset points and some intersection and offset points, are stored as vectors from a source point. If you delete a source point, any point stored as a vector from that point has null (?) coordinates when you review the database point record.

Deleting a point, line, or arc in the General Survey database

1. From the main menu, tap *Jobs / Review job*.
2. Highlight the point, line, or arc to be deleted and tap *Details*.
3. Tap *Delete*. For points, the search class changes to Deleted (normal), Deleted (control), Deleted (staked), Deleted (backsight), or Deleted (check), depending on the original search classification.
4. Tap *Accept*. The General Survey software records a note with the original point, line, or arc record, showing the time it was deleted.

When you delete a point, line, or arc, the point symbol changes. For example, for a topo point, the  symbol replaces the  symbol.

When you delete an observation that has been recorded during a [Station setup plus](#), a [Resection](#), or [Measure rounds](#) operation, the mean turned angle records and station or round residuals records will not be updated. Deleting an observation that has been used to compute an average does not automatically update the average. Use *COGO / Compute average* to recompute the average.

Note – You cannot delete points from a linked file.

Use Explorer to delete alignment files, road files, map files, or any other file type stored on the controller.

To restore a point, line, or arc in the General Survey database:

1. From the main menu, tap *Jobs / Review job*.
2. Tap the point, line, or arc record to be restored.
3. Tap *Undelete*.
4. Tap *Accept*.

Deleting features from the Map screen

1. Select the required feature(s) using one of these options:
 - Tap the feature(s).
 - Drag a box around the feature(s).
 - Tap and hold on the screen and then choose *Select* from the shortcut menu.
2. Tap and hold on the screen and then choose *Delete* from the shortcut menu.
3. Select the feature(s) to delete and then tap *Delete*.

Note - You cannot delete points, lines or arcs from a linked map file (for example, a DXF or SHP file).

Managing data in the Point manager

As an alternative to *Review job*, use the *Point manager* to manage your data.

You can easily review:

- Point coordinates
- Observations
- The **best point** and all duplicate points
- Target and antenna heights
- Codes and notes
- Descriptions
- Notes

You can easily edit:

- Target and antenna heights (single or **multiple**)
- **Point names**
- **Point coordinates**
- Codes (single or **multiple**)
- Descriptions (single or multiple)
- Notes

Using Point manager

To open *Point manager*, select *Jobs / Point manager* from the main menu. The screen that appears shows a tabulated tree structure of all points and observations in the job database and linked files.

Viewing the data

When there are duplicate points of the same name, the best point always appears first. All occurrences of points of the same name, including the best point, appear in a list below the best

point.

However, when the data is in the *Target height* view, all observations in the database appear in the order that they occur in the database.

To change the view of the data, select *Display*. For example, to [view coordinates](#), set *Display* to *Grid*; to view or edit target heights, set *Display* to [Target height](#).

Note - In *Point manager*, the *Target height* setting refers to both *antenna height* and *target height*.

To sort the data, tap the column heading.

To change the width of the column, or to hide the column, tap and drag the separator between headings.

To shrink an empty column double tap the separator to the right of the column.

Use the scroll bars to scroll horizontally or vertically through the data.

Tip - To freeze the Point name column, tap and hold the Point name column heading. To unfreeze the column, tap and hold the heading again.

To control whether deleted points are shown, tap *Options* and then select or clear the *Display deleted points* check box. Note that a wildcard search in *Point Manager* cannot display deleted points if the display of deleted points has been disabled.

Filtering data using wildcard searching

To filter the displayed information using wildcard matching, tap . The screen that appears contains *Point name*, *Code*, and *Note* fields and, if enabled, two *Description* fields.

To filter the fields appropriately, use * (for multiple characters) and ? (for a single character). The filters specified for the separate fields are processed together and only points that meet the criteria of all the filters will appear. Use * in any field that you do not want to filter. Filtering is not case sensitive.

Filter examples:

Point name	Code	Descr. 1	Descr. 2	Note	Example results
1	*	*	*	*	1, 10, 2001, 1a
1*	*	*	*	*	1, 10, 1a
1?	*	*	*	*	10, 1a
1	Fence	*	*	*	All points with a name that contains a 1 and where code = Fence
1	*Fence*	*	*	*	All points with a name that contains a 1 and a code that contains Fence
1???	*	*	*	wrong*	All points with a name that starts with 1 and is 4 characters long and a note that starts with wrong
*	Tree	Aspen	25	*	All points where code = tree and Description 1 = Aspen and Description 2 = 25

To disable the filter, tap *Reset*, or set all fields to *.

Filter settings are remembered, but are not applied if Point manager is closed. To reactivate filter settings, tap  and then tap *Accept*.

To view more information on a point do one of the following:

- To reveal all associated points and observations, tap + to expand the point tree list. Expand the subtree to view individual point information. These records can include the point coordinates, observations, antenna or target details, and quality control records.
- To open the same point form as seen in *Review job*, tap a point, or highlight a point and tap *Details*. This allows you to edit information such as the point code and attributes.

To change the format of the indented coordinates or the observations that appear when you expand the point tree, tap the coordinates or observations displayed, or highlight them and press the space key. In the list that appears, select the new data view. This allows you to review the raw conventional observations (or WGS-84 observations) and the Grid coordinates at the same time.

Using Grid (local) in the Point manager

You can use Point manager to view Grid (local) coordinates using the input transformation or a display transformation.

1. From the main menu, tap *Jobs / Point manager*.
2. Tap *Display* and then select *Grid (local)*.
3. To select the Grid (local) transformation for coordinate display, or to create a transformation, select *Options*.
4. Do one of the following:
 - To view the original Grid (local) values, select *Display original grid local* and then tap *Accept*.
 - To create a new display transformation, select *Create new transformation*, tap *Next* and then complete the [required steps](#).
 - To select an existing display transformation, select *Select transformation*, select the display transformation from the list and then tap *Accept*.

Notes

- The 'input' transformation transforms a point from the original entered Grid (local) coordinates to database grid coordinates.
- The 'display' transformation transforms a point, regardless of how it was stored, from the database grid coordinates to display computed Grid (local) coordinates.
- When viewing the original Grid (local), points not stored as Grid (local) appear as null North (local), East (local), and Elev (local).
- When you select a display transformation, all database grid points appear using the current display transformation. If the display transformation is different from the original transformation, the computed Grid (local) coordinates are different from the original entered Grid (local) coordinates.
- A point entered as a Grid (local) point is stored in its original format to the General Survey job as a Grid (local) point. Typically, the input transformation to transform the point to a

*database grid point is assigned at the time the point is entered, but the transformation can be created at a later stage and then **assigned** to the point(s) using Point manager.*

To change the input transformation:

1. From the main menu, tap *Jobs / Point manager*.
2. Tap *Display* and then select *Grid (local)*.
3. Highlight the point(s) stored as Grid (local) whose input transformation you need to change.
4. Tap *Edit* and then select *Transformations*.
5. Select the new transformation and then tap *OK*.

The new transformation is now used to transform the Grid (local) to database grid.

If the current view showed the original Grid (local), changing the input transformation does not change the Grid (local) coordinates displayed.

If the current view showed a different display transformation, changing the input transformation also changes the Grid (local) coordinates displayed.

Using station and offset in the Point manager

You can use Point manager to view points by **station and offset** relative to an entity such as a Line, Arc, Alignment, Tunnel or Road.

1. From the main menu, tap *Jobs / Point manager*.
2. Tap *Display* and then select *Station and offset*.
3. Select *Options*.
4. Select the entity type and the entity name and then tap *Accept*.

Reviewing and editing antenna and target heights

Note - In Point manager, the *Target height* setting refers to conventional target heights and the *GNSS antenna heights*.

To change a target height record and update **all** observations using that target height record, edit the target height in [Review job](#).

To change an individual target height, or group of target heights, in *Point manager*:

1. From the main menu, tap *Jobs / Point manager*.
2. Tap *Display* and then select *Target height*. In the screen that appears, the point name, from point, target height, code, and note are listed in the order they exist in the database.
 - To change the record order, tap the appropriate column heading.
 - To filter the list, tap *Filter*, select the appropriate column and then enter the filter details.

Tip - If you enter a filter value of 2 for a point name, the system will show all points with 2 in their name, including 2, 1002, 2099, or 2day. To filter for a point name "2", select the Match whole word check box.

3. To select a target or multiple targets for editing, do one of the following:
 - Tap the *Target* field.
 - Use the arrow keys to highlight the record to edit and then tap *Edit*.
 - To select multiple fields, press and hold *Ctrl* and then tap the required fields. Then tap *Edit*.
 - To select a range of fields, tap the first required field, press and hold *Shift* and then tap the last required field. Then tap *Edit*.
4. In the *Target details* form enter the new *Target height* and/or *Prism constant*. To store the changes, tap *OK*.

When measuring to the bottom notch on a [Trimble prism base](#), tap the advanced pop-up arrow () and then select *Bottom notch*.

Point manager now displays the corrected target details. In *Review job*, view the inserted target records with notes that record the old target details.

Group editing target heights (conventional) and antenna heights (GNSS)

You can use the *Point manager* to edit details of antenna heights or target heights for multiple-selected points. This function is available when the *Display* softkey setting in the *Point manager* is set to *Target height*. Use the standard Windows selection methods of *Ctrl-click* and *Shift-click* to choose the points to apply the target or antenna height edits to.

Tips

- When you edit antenna heights, you can edit the measured heights and the measurement method.
- When you edit target heights, you can edit the measured target height value, the measurement method (when applicable), and the prism constant.
- When you select points to edit, you can include points with target heights and points with antenna heights. When you tap *Edit*, two dialogs appear - one to edit antenna heights and one to edit target heights.
- You do not need to select contiguous target and/or antenna heights to edit.
- You cannot edit a selection of antenna heights that includes more than one type of antenna. In this case, select and edit the points in separate groups, according to the type of antenna used.
- You can edit a selection of different targets. In such a case, the new target heights are applied to each of the different targets but the target numbers remain unchanged.
- Some conventional measurements use calculated (system) targets, which have a zero height and zero prism constants, for example, Dual-prism offset. You cannot edit the target heights for system targets.
- You can sort *Point manager* columns to help you find and select groups of target or antenna heights to edit. Tap the column heading to sort that column.
- The *Point manager* automatically inserts the appropriate target and antenna equipment records into the job database to ensure that the correct heights and measurement methods are assigned to each point.

- When you edit points, the *Point manager* automatically inserts notes into the job database to record what was edited, the original measurement data, and the time of the edit.

Editing point coordinates using Point manager

You can use the *Point manager* to edit the coordinates of imported or keyed in points.

1. From the main menu, tap *Jobs / Point manager*.
2. To select the record to edit, tap and hold the stylus on the record.
3. Tap *Edit* and then select *Coordinates*.
4. Edit the coordinates and then tap *OK* to save the changes.

You cannot edit the coordinates of:

- raw observations
- points in linked files
- a range of records at one time

A record of the changes made are saved to the *Note* record.

Renaming point names using Point manager

You can use the *Point manager* to edit the names of points and observations.

1. From the main menu, tap *Jobs / Point manager*.
2. To select the record to edit, tap and hold the stylus on the record.
3. Tap *Edit* and then select *Point names*.
4. Edit the name and then tap *OK* to save the changes.

You cannot edit the name of

- points in linked files
- an observation to the current station if a survey is running
- a backsight observation

A record of the changes made are saved to the *Note* record.

Editing point names and point coordinates in a dynamic database

The General Survey software uses a dynamic database. If you change the name or coordinates of a record, the positions of other records that rely on that record could change or disappear.

The rest of this section describes how changes to a base station position, station setup, or backsight position can affect other positions. In addition to these record types, changes to resections, lines, arcs, compute inverse records, and others may also affect other positions. For more details on specific records that may change, see the table below.

If you rename a point name that is used as a base in a GNSS survey, or as a station setup point in a conventional survey, this does not rename the point name that is referenced in the Base record or Station setup record. You cannot edit the point name referenced in the Base record or Station setup record in any way.

If you rename the base position or station setup position, and another record with the same name **does not** exist, then the positions of all records that are computed from that base position or station setup position cannot be computed, and those records will no longer be displayed in the map.

If you rename the base position or station setup position, and another record with the same name **does** exist, then the positions of all records that are computed from that base position or station setup position may change, as they will now be computed from the next best point with the same name.

If you edit the base position or station setup position, then the positions of all records that are computed from that base position or station setup position will change.

If you edit the azimuth in an a station setup with a keyed-in azimuth to the backsight, then the positions of all records that are computed from that station setup will change.

If you edit or rename the point record that is used as a backsight in a station setup with a computed azimuth to the backsight, then the positions of all records that are computed from that station setup may change.

If you select a range of records and change their name, all the selected records are renamed to the new name that you entered.

If you rename or edit the coordinates of points, all records that contain computed deltas to other points, for example as-staked, check, and backsight observations, are not updated.

In the following table, the * symbol against a record type shows the dynamic database records that may change if the name or the coordinates of the record that was used to derive their position is modified.

Record	Names	Coordinates
Topo points (GNSS)	*	*
Rapid points	*	*
FastStatic points	*	*
Observed control points	*	*
F1 Topo points (Conv.)	*	*
F2 Topo points (Conv.)	*	*
Mean turned angle	*	*
As-staked points	*	*
Check points	*	*
Continuous points	*	*
Construction points	*	*
Laser points	*	*
Lines	*	*
Arcs	*	*
Compute inverse	*	*

Record	Names	Coordinates
Resection points	-	-
Adjusted points	-	-
Averaged points	-	-
Cogo points (computed) (see note below)	* 1	* 1
Intersection points	-	-
Offset points	-	-
Roads	-	-
Alignments	-	-
Tunnels	-	-
Calibration points	-	-
Compute area	-	-

1 - Cogo points can change if the point they are computed from is modified, but it depends on how the Cogo points were stored. If they were stored as a vector, for example Az HD VD and the base point is moved, then the Cogo point will also move.

Adding or editing codes using Point manager

To enter a code or change an existing code, tap the *Code* field. Enter the code details, and the attributes, if required. Tap *Accept* to store the changes.

To understand assigning attributes to a point, see [Using feature codes with predefined attributes](#).

Group editing codes using Point manager

You can use the *Point manager* to edit code details for more than one point at a time.

1. Use the standard Windows selection methods; press **Ctrl** or **Shift** and tap the records for which you want to change the code.
2. Tap *Edit* and then select *Codes*.
3. Enter the new code and then tap *Enter*.

If the code has attributes, you are prompted to enter them.

The new codes are updated and displayed in the *Point manager*. A note with the old code value is stored for each modified record.

Tip - You can edit Descriptions in the same way.

Adding or editing notes using Point manager

To enter a note or change an existing note, tap the *Note* field. Enter the note details and then tap *Accept* to store the changes.

Coordinate view

You can change the Coordinate view settings when:

- reviewing a point in a job
- viewing a point in the *Point manager*
- keying in a point

The following table describes the coordinate view options.

Option	Description
WGS-84	View as WGS-84 Latitude, Longitude, and Height.
Local	View as local ellipsoidal Latitude, Longitude, and Height.
Grid	View as Northing, Easting, and Elevation.
Grid (local)	View as Northing, Easting, and Elevation relative to a transformation.
ECEF (WGS84)	View as WGS-84 Earth-Centered-EarthFixed X , Y , Z coordinates
Station and Offset	View as station, offset, or vertical distance relative to a line, arc, alignment, road, or tunnel. See Station and offset .
Az VA SD	View as azimuth, vertical angle, and slope distance.
HA VA SD (raw)	View as horizontal angle, vertical angle, and slope distance.
Az HD VD	View as azimuth, horizontal distance, and vertical distance.
HA HD VD	View as horizontal angle, horizontal distance, and vertical distance.
Delta Grid	View as differences in Northing, Easting, and Elevation from the instrument point.
USNG/MGRS	View as USNG/MGRS string (based on the local ellipsoid) and Elevation.

Note - When keying in a point, and for all options except *Grid* or *Grid (local)*, the computed grid coordinates are also displayed.

If the coordinate value when viewing a point is *?*, one of the following situations may have occurred:

- The point may be stored as a GNSS point but with the *Coordinate view* field set to *Local* or *Grid* and a datum transformation and projection not defined. To correct this, change the *Coordinate view* setting to *WGS-84*, define a datum transformation and/or projection, or calibrate the job.
- The point may be stored as a *Grid (local)* point and with the *Coordinate view* field set to *Grid*, but a transformation has not been defined to convert the *Grid (local)* to a *Grid*.
- The point may be stored as a polar vector from a point which has been deleted. To correct this, restore the point.
- In a 2D survey, a projection may have been defined with the project height as null. To correct this, set the *Project height* to approximate the site elevation.

Station and offset

You can key in or review a point by Station and offset relative to a:

- Line
- Arc
- Alignment
- Tunnel
- Road

Notes

- If the selected entity has an elevation for the entered station, the elevation for the keyed in point can be defined by a V.dist value applied relative to the elevation of the vertical alignment at that station.
- For a road with templates assigned, the V.dist value is applied relative to the resulting cross section at the entered station *and* offset.
- For a tunnel with templates assigned, the V.dist value is always applied relative to the elevation of the vertical alignment at the entered station.
- If the *Coordinate view* is set to *Station and offset* relative to a road, tunnel, or alignment, then the station and offset for the point is to the intersection point of two horizontal alignment elements when:
 - the horizontal alignment includes consecutive elements that are non tangential;
 - the point is beyond the end tangent point of the incoming element but before the start tangent point of the next element; and
 - the point is on the **outside** of the horizontal alignment.

The exception to this behavior is if the distance from the point to the intersection point is greater than the distance to another element in the horizontal alignment. In that case, the station and offset for the point is to the closer element.

Where the point is on the **inside** of the horizontal alignment, then the station and offset is relative to the closest horizontal element.

Where the point is before the start of the horizontal alignment or beyond the end of the alignment, the station and offset for the point is null.

Trimble Access provides an option to use *Chainage* for the distance term instead of the default *Station*. To change this setting, see [Language](#).

QC graph

The *QC graph* screen displays a graph of quality indicators that are available from data in a job. To change the type of data to display, tap *Display*. To scroll along the graph, use the arrow buttons. To view basic details of a point, tap the graph. For more information, double tap the graph to access *Review*.

You can view a graph of:

- Horizontal precision
- Vertical precision
- Tilt distance
- Satellites
- PDOP
- GDOP
- RMS
- HA standard error
- VA standard error
- SD standard error
- Elevation
- Target height
- Attributes

Note - *Attributes can be filtered by Feature code and Attributes but only feature codes that contain numeric or integer attributes are displayed.*

Tips

- Tap a point to see details for that point. Tap again to review the point.
- To aid point selection, tap a point and then tap *Prev* or *Next* from the second row of softkeys to select the previous or next point.
- To add a note to a point, tap the bar in the graph to select the point, and then tap the append Note softkey.
- To navigate to a point, tap the point and then select *Navigate* from the second row of softkeys.
- To define the Y axis range, tap near the Y axis and from the pop-up menu define the *Minimum* and *Maximum* Y axis values.

Inserting notes

To store a note in the database:

1. Highlight a record.
2. Tap *Note*. The *Note* screen that appears displays the date and time that the current record was created.
3. Enter the note and then tap *Accept*. The note is stored with the current record. In *Review job*, the note appears below the record with the note icon.

Storing points

How you record a point determines how it is stored in the General Survey software. Points are stored either as vectors or as positions. For example, RTK points and conventionally observed

points are stored as vectors, while keyed-in points, real-time differential points, and postprocessed points are stored as positions.

To review details about a stored point, from the main menu, select *Jobs / Review job*. A point record contains information about the point, such as the point name, the code, the method, the coordinates, and the GNSS data file name. The *Method* field describes how the point was created. The coordinates are expressed as WGS-84, local, or grid coordinates, depending on the setting in the *Coordinate view* field.

To change the coordinate view settings, do one of the following:

- From the *Jobs* menu, tap *Review job*. Open the point record and then tap *Options*.
- From the *Key in* menu, tap *Points* and then tap *Options*.

Note - Define a datum transformation and/or a projection if you want to display local or grid coordinates for a GNSS point. Alternatively, calibrate the job.

Each point record uses the antenna height given in the previous antenna height record. From this, the General Survey software generates a ground height (elevation) for the point.

The following table shows how the point is stored in the *Stored as* field.

Value	What the point is stored as
Grid	Grid coordinates
Local	Local geodetic coordinates
WGS-84	WGS-84 geodetic coordinates
ECEF	WGS-84 Earth-Centered-EarthFixed X , Y , Z coordinates
ECEF deltas	WGS-84 Earth-Centered-EarthFixed X , Y , Z vector
Polar	Azimuth, horizontal distance, and vertical distance. This is a vector.
HA VA SD	A horizontal circle reading, vertical circle reading (a zenith angle), and slope distance. This is a vector.
HA VA SD (raw)	A horizontal circle reading, vertical circle reading (a zenith angle), and slope distance with no corrections applied. This is a vector.
Mag.Az VA SD	A magnetic azimuth, vertical (zenith) angle, and slope distance vector.
MHA MVA MSD	A meaned horizontal angle from the backsight, meaned vertical angle (a zenith angle), and meaned slope distance. This is a vector.
USNG/MGRS	USNG/MGRS string and Elevation

Read the *Stored as* field in conjunction with the *Method* field.

For points calculated using *Cogo/Compute point*, you can choose how to store that point. The available options depend on the selected coordinate system and the type of observation used in computing the point.

Note - Points stored as vectors are updated if the calibration or coordinate system of the job changes, or the antenna height of one of the source points is changed. Points stored as WGS-84 coordinates (for example, an offset point calculated using the *From a baseline method*) are not updated.

For GNSS points, Quality Control (QC) records are stored at the end of the point record.

Point classification

When points are stored they have either one or two classifications:

- Points that have been measured using GNSS have an observation class and a search class.
- Points that have been keyed in, computed, or measured with a conventional instrument or laser rangefinder have only a search class.

Observation class

The following table lists the observation classes and resulting solutions.

Observation class	Result
RTK	A real-time kinematic solution.
L1 Fixed	An L1 fixed real-time kinematic solution.
L1 Float	An L1 float real-time kinematic solution.
L1 Code	An L1 code real-time differential solution.
Autonomous	A postprocessed solution.
RTKxFill	A real-time kinematic solution using xFill.
SBAS	A position that has been differentially corrected using SBAS signals.
Network RTK	A real-time kinematic solution using Network RTK.
RTX	A position that has been generated by the Trimble Centerpoint RTX correction service.
WA Fixed	A fixed solution using wide-area processing.
WA Float	A float solution using wide-area processing.
OmniSTAR HP	A high-precision OmniSTAR corrected solution (HP/XP/G2)
OmniSTAR VBS	An OmniSTAR VBS differentially corrected position

Note - For postprocessed surveys, the observation class is autonomous and no precisions are recorded.

Search class

A search class is applied to a point when it is measured, keyed in, or computed. The search class is used by the General Survey software when details of a point are required for stakeout or calculations (for example, for Cogo calculations).

For more information, see [Database search rules](#).

Viewing the map

The *Map* screen is a graphical representation of features from multiple sources, including:

- points, lines, and arcs from the current job database
- layers of features including:
 - points from linked jobs and linked .csv and .txt files
 - points, lines, arcs, polylines, and other map entities such as alignments and surfaces from other file types
- background images from georeferenced image files

Use the following links to learn more about using the map:

- [Accessing the map](#)
- [3D map \(tablet controllers only\)](#)
- [Navigation softkeys and buttons](#)
- [Map display options](#)
- [Other map options](#)
- [AccessVision](#)
- [Selecting data to display in the map](#)
 - [Linking files to the current job](#)
 - [Adding data files as map layers](#)
- [Using the Map for common tasks](#)
 - [Create surface](#)
 - [Compute volume](#)

Accessing the Map

1. From the *Jobs* screen tap *Map* or in any screen tap *Map* in the status bar. The current position of the GNSS antenna is displayed as a vertical/horizontal cross. The current orientation of a conventional instrument is shown by a dotted line extending from the instrument to the end of the screen. The location of the prism is shown as a cross when a distance is measured.
2. Use the [map softkeys](#) to navigate around the map.

3D map (tablet controllers only)

A 3D map to visualize data in 3 dimensions is available on tablet controllers. You can rotate the data to view the data from different sides. 3D data visualization is useful for looking at elevation changes and detecting antenna height errors. It is great for visualizing scan data and surfaces, be it a true 3D scan, or simply a survey of a building façade. The 3D map is also available in [AccessVision](#) screens.

If required, disable the 3D map functionality so that the map always shows a the 2D view. To do this, in the 3D map tap the *Options* softkey and then clear the *3D map* check box. Tap *Accept*.





Note - The [CAD toolbar](#) is not available when using the 3D map. To use the CAD toolbar, disable the 3D map.

Navigation softkeys and buttons

Some softkeys can operate in an "active" mode. The effect of tapping on the map depends on the active softkey selected.



2D map softkeys





The following softkeys appear on the map for all non-tablet controllers, and in the 2D map on a tablet controller when the 3D map is disabled.

Softkey	Function
	<p>Tap this softkey to zoom in.</p> <p>Tap and hold the softkey to make it active. When active, tap the area of the map to zoom in on, or drag to create a box around the area of interest.</p>
	<p>Tap this softkey to zoom out.</p> <p>Tap and hold the softkey to make it active. When active, tap the area of the map to zoom out from.</p>
	<p>Tap this softkey to shift the center of the map area to another part of the map.</p> <p>Tap the softkey to make it active. When active, tap an area of the map to center on, or tap and drag the map area to where you want to reposition the image.</p>
	<p>Tap this softkey to zoom extents and show all features on the screen.</p> <p>Note - The current position of the GNSS antenna is not included unless it is currently being used for GPS search.</p>

Map toolbar (tablet controllers only)

The map toolbar appears on the 3D map.

Button	Function
<p>Select</p> 	<p>Tap Select to select features.</p> <p>Tap the features on the map to select, or drag to create a box around the features you want to select. For more information, see Selecting a feature from the map.</p> <p>To clear the current selection, double-tap an empty part of the map.</p>
<p>Zoom in</p> 	<p>Tap Zoom in to zoom in.</p> <p>Tap and hold the button to make it active. When active, tap the area of the map to zoom in on, or drag to create a box around the area of interest.</p> <p>Alternatively, place two fingers on the screen and stretch out to zoom in even when the map is not in Zoom in mode.</p>
<p>Zoom out</p> 	<p>Tap Zoom out to zoom out.</p> <p>Tap and hold the button to make it active. When active, tap the area of the map to zoom out from, or drag to create a box that the current screen content will fit into.</p>

Button	Function
	Alternatively, place two fingers on the screen and pinch in to zoom out even when the map is not in Zoom out mode.
Pan 	<p>Tap Pan to activate Pan mode. Tap an area of the map to center on, or tap and drag the map area to where you want to reposition the map.</p> <p>If you are using a controller that has arrow keys, you can use the arrow keys to pan even when the map is not in Pan mode.</p> <p>Alternatively, place two fingers on the screen and slide in the desired direction to move the view even when the map is not in Pan mode.</p>
Zoom extents 	<p>Tap Zoom extents to zoom to the map extents.</p> <p>Note - <i>The current position of the GNSS antenna is not considered part of the map extents unless it is currently being used for GPS search.</i></p>
Orbit 	<p>Tap Orbit to orbit the data around an axis. Tap the map and then drag to rotate the view.</p> <p>The NE axes icon rotates accordingly, to show the orientation of the North and East elevations.</p>
Predefined view 	<p>Tap Predefined view to select a predefined view of the map.</p> <p>Tap the button and then select <i>Plan, Iso, Top, Front, Back, Left, or Right</i>.</p> <p>When in <i>Plan</i> view, additional options are available from the tap and hold menu. These options are not available in the other predefined views.</p> <p>The <i>Iso</i> view shows an isometric view of the data where each angle is 60 degrees. Select <i>Iso</i> again to rotate the view by 90 degrees.</p>
Show 	<p>Tap Show and then select the appropriate menu to select which items are displayed in the map. Select from <i>Settings, Scans, Filter, Layers, and Pan to</i>. For more information, see Navigation softkeys and buttons below.</p>

Additional navigation options

To display more navigation options, in the map view tap and hold the *Map* button in the status bar (or in widescreen mode tap and hold the arrow on the far right side of the map). The following options are available:

- Zoom to the previous view
- Zoom to a default scale and location
- Set a default scale and location

Map display options

Note - *Some options are job-specific. For the 2D map these settings are: color gradient, surface triangle, and vertical offset display. For the 3D map these settings are: vertical exaggeration scale, ground plane, color gradient, surface triangle, surface side, and vertical offset display.*

Display options

To control which items are displayed in the map:

- In the 2D map, tap the up arrow to access more softkeys and then tap *Options*.
- In the 3D map, tap **Show** and then select *Settings*.

You can configure the following:

- Select the *Names* check box to display name labels next to points in the map. Labels are not displayed for points in DXF files, Shapefiles, and LandXML files.
- Select the *Codes* check box to display code labels next to points in the map. Labels are not displayed for points in DXF files, Shapefiles, and LandXML files.
- Select the *Station values* check box to display road and alignment station values.
- Select the *Elevations* check box to display elevations in the map. Elevations are not displayed for points in DXF files, Shapefiles, and LandXML files.
- Select the *Point symbols* check box to display the points symbols for each point.
- Select the *Stakeout list points* check box to display points from the stakeout list in the map.
- Select the color to use for map labels from the *Label color* list.
- Select the *Hatch polygons* check box to hatch polygons in a background file.
- Select the *Automatic pan to your current position* check box to automatically center the map on your the current position if it is available.
- Select the *CAD toolbar* check box to display the CAD toolbar in the map. This option appears on tablet controllers only when the [3D map is disabled](#).

When the 3D map is enabled, you can also:

- Set the vertical exaggeration scale in the *Vertical exaggeration* field. The default setting of 1 indicates that the horizontal and vertical scales are identical, which gives a true representation of the data. Enter a larger value in the *Vertical exaggeration* field to emphasize vertical features which might be too small to identify relative to the horizontal scale.

Ground plane options

To configure the ground plane displayed in the 3D map, tap **Show** and then select *Settings* and select page 2.

Select the *Display ground plane* check box and then enter the elevation of the ground plane to display the ground plane. The ground plane elevation is used as a visual reference when viewing the map in 3D. It is not used in calculations.

Surface options

To configure the display of surfaces in the map:

- In the 2D map, tap the up arrow to access more softkeys and then tap *Options* and select page 2.
- In the 3D map, tap **Show** and then select *Settings* and select page 3.

You can configure the following:

- Select the *Display color gradient* check box to display surfaces with a color gradient.
- Select the *Display triangles* check box to display surface triangles.
- Enter a value in the *Offset to DTM (Vertical)* field to raise or lower the surface when viewing from the map.

When the 3D map is enabled, you can also:

- Select the *Display sides* check box to display the sides of a surface.

Scan settings

Select the scan(s) to display on the map.

Filter settings

To filter the data shown in the map:

- In the 2D map, tap the up arrow to access more softkeys and then tap *Filter*.
- In the 3D map, tap **Show** and then select *Filter*.

Select which features are displayed in the map by selecting them in the list.

Tap  to filter points by *Point name*, *Code*, *Descriptions* (if enabled) and *Note*. For more information, see [Filtering data using wildcard searching](#).

Layer settings

To control the display of files or layers added to the map:

- In the 2D map, tap the up arrow to access more softkeys and then tap *Layers*.
- In the 3D map, tap **Show** and then select *Layers*.

For more information, see [Adding data files as map layers](#).

Pan to settings

To configure pan settings:

- In the 2D map, tap the up arrow to access more softkeys and then tap *Pan to*.
- In the 3D map, tap **Show** and then select *Pan to*.

Enter a point name and scale value.

Tap the *Here* softkey to center the map at the current position.

Other map options

Tap the *Options* softkey to configure the following:

Option	Function
<i>Auto measure</i>	Select the <i>Auto measure</i> check box to automatically start a measurement when you press the measure key.
<i>Pan to</i>	Clear the <i>Widescreen</i> check box to resize the map so that the status bar appears to the right of the map.
<i>3D map</i>	Select the <i>3D map</i> check box to use the 3D map. Clear the check box to revert to the 2D map. For more information, see 3D map (tablet controllers only) . Note - The map view is not available in an <i>AccessVision</i> screen if the 3D map is disabled.

AccessVision

AccessVision provides a useful graphical display within task screens. AccessVision incorporates the map view and the video view within the current screen to provide immediate visual feedback and avoid having to switch back and forth between screens. Task screens that support AccessVision include measure, key in, cogo, and station setup screens.



Screens that already provide a graphical display, such as navigate to point, do not support AccessVision.

Note - AccessVision is supported only on tablet controllers. The map view is not available in an AccessVision screen if the 3D map is disabled.

When viewing a screen that supports AccessVision, the graphical display is on the left side of the screen. When the controller is connected to an instrument that has Trimble VISION technology, tap the icon on the bottom right corner of the graphical display to toggle between the map and the video view. Selecting points in the graphical display populates the fields on the right of the screen.

Tip - The softkeys available in an AccessVision screen are always the softkeys for the task screen. When in an AccessVision screen, the arrow keys on the tablet controller control the map or video view, except when in the *Joystick* screen.

To control the display and size of the graphical display in an AccessVision screen:

Tap...	To...
	Hide the graphical display
	Make the graphical display full screen.
	Revert to showing both the graphical display and the task screen.

Selecting data to display in the map

By default, points, lines, and arcs from the current job database appear on the map.

You can add more data to the map, including:

- [background images](#) from georeferenced image files
- [layers](#) of features including:
 - points from linked jobs and linked .csv and .txt files
 - points, lines, arcs, polylines, and other map entities such as alignments and surfaces from other file types

Background images

The following image file types and associated world files are supported:

Image files	World files
Bitmap (.bmp)	.wld .bpw .bmpw
JPEG (.jpg)	.wld .jgw .jpgw
JPEG (.jpeg)	.wld .jpegw
PNG (.png)	.wld .pgw .pngw

Note - Only Bitmap, JPEG, and PNG files with an associated world file are available for selection. Rotated images are not supported.

If you have a Survey-Advanced license, you can export JPEG georeferenced image files from Trimble Business Center using [Image / Capture image]. Trimble Business Center enables large files to be reduced in size for improved performance on the controller.

More memory is required to load a BMP file than is required to load a DXF file, and JPEG/PNG files are a compressed format file that requires more memory again when they are uncompressed and loaded into memory.

To compare the memory required to load a:

- BMP file compared to a DXF file, multiple the BMP file size by four; so a 850 KB BMP file uses 3.4 MB of memory.
- JPEG/PNG file compared to a DXF file, multiple the JPEG/PNG image height by width multiplied by four; for example if a 130 KB image is 1024 pixels wide by 768 pixels high (1024 x 768 x 4 = 3.14 MB), and so would require 3.14 MB of memory to load the file.

Layers

By default points, lines, and arcs from the current job database appear in the map.

To add features from other files to the map, see one of the following:

[Linking files to the current job](#)

[Adding data files as map layers](#)

Linking files to the current job

You can link files (*.csv, *.txt, or *.job) to your current job to provide easy access to additional data.

Use a linked file to access points that do not exist in the current job, or that you do not want to import into the current job, such as control points. Linked CSV points appear as a comma (,). Linked points from another job appear with their original point symbol. All linked points appear blue.

You can use points from a linked file to:

- stake out without having the design points in the job
- enter values into *Point name* fields, such as for Cogo functions
- navigate to control or check shots from previous surveys

For more information on using linked points, see [Selecting points](#).

Notes

- You can link a file from any folder.
- In a linked job, you cannot access lines, or arcs.
- You can only review points in a linked file from the map. Once you select a linked point and copy it into the current job, it appears as a "c" in the map.
- You can link multiple files (*.csv *.txt *.job). When the point does not exist in the current job, but does exist in multiple linked files, the point in the first linked file is used. If multiple points of the same name exist in a linked job, the [search rules](#) work within that job to find the best point.

Transferring linked files

You can transfer linked CSV files from the office computer, transfer files between controllers, or export points to a CSV file from a previous job.

Before you transfer a CSV file, make sure the data in the file is in the format: Point name, First ordinate (Northing or Easting), Second ordinate (Northing or Easting), Elevation, Point code.

Note - The coordinate order (Northing and Easting ordinates) in the comma delimited file must be the same as the setting in the Coordinate order field in the Units screen.

Use the Data Transfer utility or Windows Mobile Device Center to transfer the file from the office computer to the Trimble controller. For more information, see [Transferring files between the controller and the office computer](#).

To select linked files:

1. From the General Survey main menu, select *Jobs / Properties of job* and then tap the *Linked files* button. The *Linked files* screen that appears lists the files in the last used folder.
2. Tap the file(s) that you want to use for the current job or tap *All* to select all files.

Tip - To add files from another folder to the list, tap *Add*, navigate to the required folder and then select the file(s) to add.

3. If [Advanced geodetics](#) is enabled, and you select a CSV or TXT file, you must specify if the points in the linked file are Grid points or Grid (local) points.
 - Select *Grid points* if the points in the CSV/TXT file are grid points.
 - Select *Grid (local) points* if the points in the CSV/TXT file are Grid (local) points and then select the input transformation to transform them to grid points.
 - To assign the transformation later, select *Not applied, this will be defined later*, and then tap *Accept*.
 - To create a new display transformation, select *Create new transformation*, tap *Next* and then complete the [required steps](#).
 - To select an existing display transformation, select *Select transformation*, select the display transformation from the list and then tap *Accept*.
4. Tap *Accept* to save any changes.

Tip - If you selected *Not applied, this will be defined later* when linking a file containing Grid (local) coordinates, and you later want to assign an input transformation to this file, you must un-link and then re-link the file.

For more information on Grid (local) coordinates, see [Local transformations](#).

To import points from a linked file to the current job, select *Jobs / Import/Export / Receive data*. When using points from linked files, make sure that they use the same coordinate system as the job that they are being brought into.

Adding data files as map layers

General Survey software supports the display of the following files as map layers:

- AutoCAD (ASCII) files (.dxf)
- Surpac files (.str) - typically used in Mines
- ESRI Shapefiles (.shp)
- LandXML files (.xml)
- Alignments files (.rxl)
- Trimble roads (.rxl)
- Surfaces or digital terrain models (.dtm .ttm .xml)

Only .dxf, .str, and .shp files support layers. Layers in these files become layers in the map. For other file types, each file is added to the map as a single layer. Files that support layers enable you to control visibility and selectability for each layer in a file. If there are no layers, you can control the visibility and selectability of the entire file. See [Changing the visibility and selectability of layers and files](#).

To transfer the files to the controller, use the Trimble Data Transfer utility or Windows Mobile Device Center.

Adding the file to the map









To select a file to view in the [Map](#) screen as a layer, do one of the following:

- Select *Jobs / Properties of job / Active map*.
- In the 2D map, tap the *Up* softkey to access additional softkey functions and then tap *Layers*.
- In the 3D map, tap  and then select *Layers*.

Data files that are in the [project folder](#), including all .rxl, LandXML, image, and surface files, automatically appear in the tree list view. To add files from another folder to the list, tap *Add*, navigate to the required folder and then select the file(s) to add.

Files that are listed but show no icon next to them are added to the map but are not visible.

The following table explains the icons that appear beside the file names:

File icon	Layer icon	indicates...
No icon	-	the file is not selected
	-	the file has been loaded but there are no supported entities in the file to display
	-	some layers are visible in the map but nothing can be selected
	-	all layers with supported entities are visible in the map, but nothing can be selected
	-	some layers are not visible in the map, but others are both visible and can be selected
	-	all layers with supported entities are visible in the map, and some of those can also be selected
	-	all layers with supported entities are visible in the map and can be selected
-	No icon	the current layer is not visible in the map
-		there are no supported entities in the layer to display
-		the current layer is visible in the map
-		the current layer is visible and selectable in the map

Notes

- *If the selectable icon does not appear beside the layer name, the layer does not contain any features that can be selected.*
- *Layers with filenames that contain invalid characters (such as a dollar sign or parentheses) are not shown in the tree view or in the map.*

Changing the visibility and selectability of layers and files

To display and make features in the file selectable, or to disable layers and files:

Tap...		To...
	+	expand the file to display all layers
	-	minimize the file and hide all layers
the file name	once	display all layers within the map file.
	twice	make all layers within the map file selectable.
	three times	disable all layers within the map file
the layer name	once	display all layers within the map file
	twice	make all layers within the map file selectable
	three times	disable all layers within the map file
<i>All</i>	once	display all layers within the map file
	twice	make all layers within the map file selectable
<i>None</i>		deselect all files and layers

Once the file is loaded, you can switch between the map view and the Active Map screen and then select or deselect the layers you want to view.

Selectable feature operations

Features in layers that you have set as visible and selectable can be used in the following operations:

- Navigate to a point
- [Stakeout - points](#)
- [Stakeout - lines](#)
- Stake polylines contained in DXF, STR, SHP, and LandXML files
 - To explode polylines into individual line and arc segments, select the *Explode polylines* check box in the *Layers Options* screen.
- [Stakeout - arcs](#)
- [Stakeout - alignments](#) (polylines)
 - Active map lines, arcs, and polylines can be selected for stakeout only from the map.
- [Stakeout - offset alignments](#)
- Auto stakeout - points and lines
- [Stakeout - digital terrain models](#)
 - To see cut or fill values relative to a DTM, make the DTM file active/selectable.
- [Create nodes](#)
- Cogo calculations
 - [Compute inverse](#)
 - [Compute distance](#)

- [Compute intersection](#)
- [Surface creation and volume calculations](#)
- Review from the map
- [Key in - alignments](#) (only available from General Survey).
- Define - roads (only available from the Roads application).
- Define - tunnels (only available from the Tunnels application).
- Auto stake - mines (only available from the Mines application).

Creating nodes

To create points at the ends of lines and arcs and at all points along a polyline, or at the center of DXF circle and arc elements, select the *Create nodes* check box in the *Options* screen when selecting the layer to display in the map. The created points can then be selected for stakeout or cogo calculations.

This option applies to DXF files, ESRI Shapefiles, and LandXML Parcels (polylines). Creating a point at the center of a DXF arc element does not apply to arc elements that are part of a polyline.

Surpac background files already have the node points available. Clearing the *Create nodes* check box does not hide these node points.

Note - *Because Shapefiles do not support arcs, arcs are often represented as a series of short lines resulting in a large number of points. Performance may be impacted when Create nodes is selected.*

Appearance in the map

Layer files are loaded into the job when the map is opened or when the map selection screen is opened.

You can display more than one layer at a time.

Features in layers can be made visible and selectable but they cannot be edited or deleted.

Displayable and selectable entities

DXF files

Displayable and selectable DXF entities:

- ARC, CIRCLE, INSERT, LINE, POINT, POLYLINE, LWPOLYLINE.

Display only DXF entities:

- 3D FACE, SPLINE, SOLID, ATTRIB, TEXT, MTEXT.
- Control characters: C - diameter symbol, D - degree symbol, P - plus/minus symbol, % - percentage symbol.

Extrusion arcs contained in a DXF file are displayed correctly in the map, but cannot be made active. Extrusion arcs form an ellipse in plan view and the staking of ellipses is not supported.

Shapefiles

Supported Shapefile entities:

- Null shape, Point, PolyLine, Polygon, MultiPoint, PointZ, PolyLineZ, PolygonZ, MultiPointZ, PointM, PolyLineM, PolygonM, MultiPointM, MultiPatch, Hatching.

LandXML files

Supported LandXML entities:

- Points (CgPoint elements), Lines (Parcel and PlanFeature elements), Surfaces
- Only points, lines, surfaces, and alignments that are contained in elements directly under the primary LandXML element are supported.

If a surface in a LandXML file is too large to be loaded into the controller memory, it will be skipped. If there are overlapping surfaces on the map, the interpolated elevation will be that of the first surface returning a non-null elevation (the surface with the first name alphabetically).

Feature names

For Shapefiles, DXF and STR files a name is generated for every selectable feature in the file. For Shapefiles, the name is the first five characters of the Shapefile name, followed by a file index number, then a space and then the line number in the Shapefile where this feature is defined. For DXF files, the name is the first 8 characters of the layer name, followed by a space and then the line number of the feature in the DXF file. For DXF files from Trimble Business Center the entity name, where present, is used. For Surpac (.str) files, points and polylines are placed in layers based on their string numbers. Polygons are named with their counter within the string layer.

A code can be generated for every selectable feature within a map file. This is derived from the attributes stored in the DXF file; often, it is the name, code, and attributes of features in the original file. For Surpac (.str) files, if points have codes they are respected.

You can review a selectable feature in the map to find the file and layer name.

Colors

Points, lines, and arcs in the current job database appear in black.

Active points in map files appear in blue.

Lines and arcs appear in the colors defined in the map file.

Feature code processing colors appear in the color defined in the feature code file (.fxl files from Trimble Business Center only).

Note - All line work features that are coded as white are drawn in black.

Coordinates

Only grid coordinates are displayed. If you have not defined a projection, only points stored as grid coordinates appear.

Grid (local) coordinates cannot be displayed if the input transformation was not defined.

If the *Grid coords* field in the [Cogo settings](#) screen is set to Increase South-West or Increase South-East, the map display is rotated by 180° such that increasing south coordinates are displayed up the screen.

Some applications use a value such as -9999.999 to represent null. For the General Survey software to correctly treat this value as null you must correctly define the *DXF null elevation* field, available under Options from the map selection screen.

Values are considered to be null if they are less than or equal to the null elevation value. For example, if the null elevation is -9999, then -9999.999 is also considered to be null.

Using the Map for common tasks

Selecting features from the map

To select a feature from the map, do one of the following:

- Tap the required feature(s) from the map area. If there is more than one feature in the highlighted area, a list of features in this area appears. Select the features as required and then tap *OK* to return to the map.

Tip - When selecting a line, arc, or polyline to stakeout, tap near the end of the line, arc, or polyline that you want to designate as the start. Arrows are then drawn on the line, arc, or polyline to indicate the direction.

If the direction of the line, arc or polyline is incorrect, tap the line, arc or polyline to deselect it and then tap it at the correct end to reselect the direction required.

The direction of alignments and Trimble roads (.rxl files) is defined when they are created, and cannot be changed.

Note - *The offset directions are not swapped when the line direction is reversed.*

- Drag a box around the features you want to select.

When multiple features are selected in this way they are typically sorted in the order in which they are stored in the database. If the order of the entities in the selection is important, you should select them one by one.

To select a feature from a map file, the map file or layers must be made selectable.

- Tap and hold on the map and then select *Select* from the shortcut menu.

This option is useful when deleting points.

Deselecting a feature from the map

- Tap the selected feature to deselect it. If there is more than one feature within the highlighted area, a list of features within this area appears. Deselect the features as required. Tap *OK* to return to the map.
- Tap and hold on the map and select *List selection* from the shortcut menu. A list of the selected features appears. Deselect the features as required.
- To clear the entire selection, double-tap off the selected features. Alternatively, tap and hold on the map and select *Clear selection* from the shortcut menu.

Carrying out a task using the selected feature(s)

- Measure

If there are no features selected, tap *Measure* to measure the current position.

Tip - To change the code and/or descriptions when using *Measure* from the map, select a point in the map whose settings you want to be the default, tap and hold on the map briefly and then select *Set point details*. Alternatively, if you want to change defaults values, but do not want to use the default from an existing point, make sure that there are no features selected before you set point details.

- Stakeout

- If one or more features are selected, tap *Stakeout* to stake out the selected feature(s).
- If more than one point is selected, the points are added to the *Stake out points* list, from where you can select them for stakeout.
- If more than one line or arc is selected, the first item selected is the one used for stakeout.
- Double-tap a feature to stake out. If there is more than one feature within the highlighted area, a list of features within this area appears. Select the feature to stake out.

Tip - If two points are selected, tap and hold on the map and then select *Stake out line* to stake a line defined by the two selected points.

If the selection contains different feature types (points, lines, arcs), only features of the first type selected can be staked out from the map. To stake out other feature types, clear the selection then reselect the other features.

Setting default point details

Tap and hold briefly on the map and then select *Set point details* from the menu.

Use *Set point details* to set the *Next point name*, *Code*, and *Description 1 and Description 2* (if enabled) that will be used as the defaults the next time you measure a point.

If you select a single point in the map when you select *Set point details*, the next available point name, and the code and descriptions of the selected point, become the defaults.

Tap and hold shortcut menu in the map

Tap and hold on the map area to access a shortcut menu. The shortcut menu provides quick access to common tasks. The tasks depend on the number and type of features selected.

In the following table, the * symbol against a task shows that you can access it through the shortcut menu for the feature at the top of that column.

Tap and hold menu options that are available for features in the current job:

Task	Feature				Line	Arc
	No Features	One point	Two points	Three or more points		
Review	-	*	*	*	*	*
Select	*	*	*	*	*	*
Store a point	*	-	-	-	-	-
List section	-	*	*	*	*	*
Clear section	-	*	*	*	*	*
Widescreen	*	*	*	*	*	*
CAD toolbar	*	*	*	*	*	*
Delete	-	*	*	*	*	*
Stake out point	-	*	*	*	-	-
Stake out line	-	-	*	-	*	-
Stake out arc	-	-	-	-	-	*
Create/Stakeout alignment	-	-	*	*	*	*
Stake out alignment	-	-	*	*	*	*
Stake out road (Roads only)	-	-	*	*	*	*
Measure calibration point	-	*	-	-	-	-
Navigate to point	-	*	-	-	-	-
Turn to	*	*	-	-	-	-
Compute inverse	-	-	*	*	-	-
Area calculations	-	-	-	*	*	*
Compute intersection	-	-	-	-	*	*
Subdivide a line	-	-	-	-	*	-
Subdivide an arc	-	-	-	-	-	*
Offset line	-	-	-	-	*	-
Key in point	*	-	-	-	-	-
Key in line	-	-	*	-	-	-
Key in arc: 3 points	-	-	-	*	-	-
Key in arc: 2 points + center	-	-	-	*	-	-

Task	Feature				Line	Arc
	No Features	One point	Two points	Three or more points		
Key in alignment	-	-	*	*	*	*
Create surface	-	-	-	*	-	-
Compute volume	-	-	-	*	-	-
Store road (Roads only)	-	-	*	*	*	*
Store tunnel (Tunnels only)	-	-	*	*	*	*
Set point details	*	*	-	-	-	-
Check backsight	*	-	-	-	-	-
Check shot	-	*	-	-	-	-

Tap and hold menu options that are available for features in a linked file or active map file:

Task	Feature							Alignment	Trimble road
	One point	Two points	Three or more points	Active map line	Active map arc	Active map polyline			
Review	*	*	*	*	*	*	*	*	
Select	*	*	*	-	-	-	-	-	
List section	*	*	*	*	*	*	*	*	
Clear section	*	*	*	*	*	*	*	*	
Widescreen	*	*	*	*	*	*	*	*	
CAD toolbar	*	*	*	*	*	*	*	*	
Delete	-	-	-	-	-	-	-	-	
Stake out point	*	*	*	-	-	-	-	-	
Stake out line	-	*	-	*	-	-	-	-	
Stake out arc	-	-	-	-	*	-	-	-	
Create/Stakeout alignment	-	*	*	*	*	*	*	*	
Stake out alignment	-	*	*	*	*	*	*	*	
Stake out road (Roads only)	-	*	*	*	*	*	*	*	
Measure calibration point	*	-	-	-	-	-	-	-	
Navigate to	*	-	-	-	-	-	-	-	

Task	Feature			Active map line	Active map arc	Active map polyline	Alignment	Trimble road
	One point	Two points	Three or more points					
point								
Turn to	*	-	-	-	-	-	-	-
Compute inverse	-	*	*	-	-	-	-	-
Area calculations	-	-	*	*	*	*	-	-
Compute intersection	-	-	-	*	*	-	-	-
Subdivide a line	-	-	-	-	-	-	-	-
Offset line	-	-	-	*	-	-	-	-
Subdivide an arc	-	-	-	-	-	-	-	-
Key in point	-	-	-	-	-	-	-	-
Key in line	-	*	-	-	-	-	-	-
Key in arc: 3 points	-	-	*	-	-	-	-	-
Key in arc: 2 points + center	-	-	*	-	-	-	-	-
Create surface	-	-	*	-	-	-	-	-
Compute volume	-	-	*	-	-	-	-	-
Store road (Roads only)	-	*	*	*	*	*	*	*
Store tunnel (Tunnels only)	-	*	*	*	*	*	-	-
Set point details	*	-	-	-	-	-	-	-
Check backsight	*	-	-	-	-	-	-	-
Check shot	-	-	-	-	-	-	-	-

Notes

- If you select one or more triangles in a surface (TTM files only), the [Delete selected triangles](#) option is available from the tap and hold menu.
- If you select a point with the same name as another point in the database, then select the [Review](#) or [Delete](#) option from the shortcut menu, a list of the duplicate points appears. Select the point you want to review or delete.

- *Field fill-in.* Enter feature names into fields by selecting from the map. Select the feature(s) from the map then select a survey function, such as Cogo or Stakeout. The selected feature(s) are automatically entered into the appropriate fields.
- *Map selection list.* The Map selections option is available on the right side of the feature name field when you have selected features from the map. Tap it to access the list of the selected features. Only features that are specific to the field are shown.
- You cannot use General Survey to delete points from linked files. Points from linked files do not appear in the Review screen list of deletable points.
- Set point details is not available on the Trimble tablet when the **CAD toolbar** is displayed.
- Turn to is available in a conventional survey when a station setup has been completed, and no points are selected. When chosen it turns to the position where the stylus tapped on the screen.
- Check backsight and Check shot options from the map are available only in conventional surveys.
- The Key in point option is not available in 3D mode. The Turn to option is available for points in the map, but is not available when in 3D mode for a tap and hold location without a point. The 3D map is supported on tablet controllers only.
- The Tap and hold menu options are reduced when you are in line drawing or arc drawing mode from the CAD toolbar.

Surfaces and volumes

Surfaces can be created and volumes computed in the 2D map on a non-tablet controller, and the 2D or 3D map on a tablet. Because computations with surfaces and volumes often require processing a lot of data, with larger datasets performance will be better on a tablet. Computations with smaller datasets, for example simple stockpiles, can be performed on non-tablet controllers.

From the tap and hold menu on the map, you can select the following options.

Create surface

Create surface becomes available when there are three or more 3D points selected on the map. A surface is generated from the current point selection and stored as a Triangulated Terrain Model file (surface name.ttm) in the current **project folder**. You are prompted to enter a name for the surface. The newly-created surface is linked to the current job as an Active map file.

For more information on the display of a color gradient, display of triangles, and applying a vertical offset for a surface, see [Map softkeys and options](#).

Delete selected triangles

Delete selected triangles becomes available when one or more triangles in a surface from a TTM file is selected. Use this option to modify the surface, if required, before performing a volume calculation.

Note –

- A triangle can be selected only if one TTM model is displayed and the display surface triangles option is enabled. For more information, see [Map display options](#).
- A triangle can be selected only if no other entities, such as points, are selected. To make triangle selection easier, hide other entities using the Filter softkey.
- The Delete selected triangles option is not available if you select all the triangles in the surface.
- To select triangles in the 3D map, the map must be in Plan view.

Compute volume

Like *Create surface*, *Compute volume* becomes available when three or more 3D points are selected on the map. It also generates a surface from the current point selection. However, once the surface is created, it takes you to the [Compute volume](#) option in the *Cogo* menu.

Selecting points

Selecting points from the map

From the tap and hold menu in the map, use the *Select* option to select points from the current job as well as points in files linked to the current job.

Select from

Use the *Select from* menu to specify where to select the points from. Options are from the Current job, Current job and linked files, or Scan files.

Scan files list any scan files (*.tsf) created in the current job using the Scanning option and the Trimble VX spatial station. You can select multiple scan files.

Notes

- You can select scan files only when the current job has scan data associated with it.
- Use the *Select* softkey to edit the list of selected scan files; use the *Reset* softkey to deselect all scan files.

To select points from the current job or the current job and linked files, define your selection using any combination of the following fields: Point name or Point range, Code, Description 1, Description 2, Minimum elevation, and Maximum elevation.

Notes

- Use the advanced pop-up arrow () to toggle between the Point name field and the point range (From point, To point) fields.
- Use wildcards in these fields to make multiple selections. Use * for multiple characters, and ? for a single character.
- If points are already selected, an Append to current selection check box appears on screen. Clear this option if you want to overwrite the current selection.

- Use the *Reset* softkey to clear all selection criteria from the fields.
- Any point selections made in the *Select* screen can be edited in the map view.

Adding points to a list

The Trimble Access software allows you to perform some functions, such as [staking points](#), [applying a transformation](#), [defining a plane](#) and [export](#), on a list of points. To create the list of points, tap *Add* and then use one of the following methods to add points to the list:

Method	Description
Enter single point name	Enter a single point name in the current job or linked files. To enter a point from a linked file into a <i>Point name</i> field, access the field and key in the point name. A linked point entered into a point name field is copied into the current job database.
Select from list	Select from a list of all points in the current job and linked files. Tap a column name to sort points by that column.
Select using wildcard search	Select from a filtered list of all points in the current job and linked files.
Select from file	Add all points from a defined CSV or TXT file.
All grid points	Add all grid points from the current job.
All keyed in points	Add all keyed in points from the current job.
Points within radius	Add all points within a defined radius from the current job and linked files.
All points	Add all points from the current job, linked files, and any scanned files referenced in the job.
Points with same code	Add all points with a defined code from the current job and linked files.
Points by name range	Add all points within a name range from the current job and linked files.
Section of job	Add all points in chronological order from the first occurrence of "From point" through to and including the first occurrence of "To point".
Current map selection	Add all points currently selected in the map.
Scan file points	Add all points from scanned files referenced in the job. Select from a list of referenced scan files.

Notes

- The *Current map selection* and *Scan file points* methods are not available when applying a transformation. However, any points selected in the map automatically populate the list.
- You must create a new list of points for each software function that allows a point list. The same points list is not reused, for example, when staking out points and then exporting points.
- When you add points to the list for stakeout using the *Select from file* option, you can add them from the linked file even if the point in the linked file already exists in the current job. The *Select from file* option is the only way you can **stake a point** from a linked file when a point of the same name exists in the current job.
- If a linked job contains two points of the same name, the point with the higher class is displayed.

For more information, see:

[Staking out points](#)

[Measure points on a plane](#)

[Import and export fixed format files](#)

[Transformations](#)

Units

To configure the Units, tap *Jobs / Properties of job / Units* and change the fields as required.

Tip - In some fields (for example, *Azimuth*), you can enter a value in units other than the system units. The *Units* softkey appears in these fields. When you tap *Enter* to accept the field, the value is converted to the system units.

Use *Units* to configure the display of the following settings:

This setting Specifies how the following values are displayed	
Distance and grid coords	Distance and Northing/Easting coordinates
Height	Height and elevation
Distance display	The number of decimal places in all distance fields. When the <i>Distance and grid coordinates</i> field is set to US survey feet or International feet you can configure the distance display to be in feet and inches. Supported fractions of an inch include: 1/2", 1/4", 1/8", 1/16" and 1/32".
Coordinate display	The number of decimal places in all Northing/Easting coordinate fields
Area display	The number of decimal places for a computed area
Volume display	The number of decimal places for a computed volume
Angles	Angles

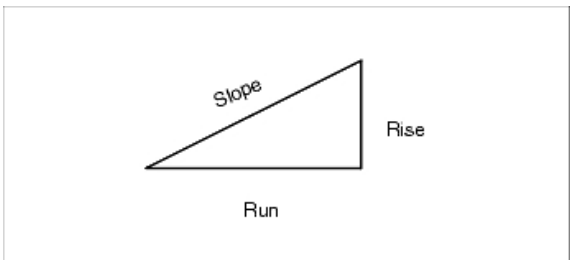
This setting	Specifies how the following values are displayed
Azimuth format	Azimuths
Lat / Long	Latitude and longitude
Temperature	Temperature
Pressure	Pressure
Coordinate order	<p>Coordinates</p> <p>The order for the displayed grid coordinates can be set to:</p> <ul style="list-style-type: none"> • North-East-Elev • East-North-Elev • Y-X-Z (equivalent to East-North-Elev - field prompts changed) • X-Y-Z (equivalent to North-East-Elev - field prompts changed) <p>For the Y-X-Z and X-Y-Z options, the convention used defines that the Y axis is the East axis and the X axis is the North axis.</p>
Station display (also known as Chainage in some countries) This defines the distance along a line, arc, alignment, road or tunnel.	<p>Station</p> <p>The station values can be displayed as either:</p> <ul style="list-style-type: none"> • 1000.0 where the values are displayed as entered • 10+00.0 where the + separates the hundreds from the remaining values • 1+000.0 where the + separates the thousands from the remaining values • <i>Station index</i> <p>The <i>Station index</i> display type uses an extra <i>Station index increment</i> field value as part of its definition. The station value is displayed as per the 10+00.0 option, but the value before the + is the station value divided by the <i>Station index increment</i>. The remainder is displayed after the +. For example if the <i>Station index increment</i> is set to 20, a station value of 42.0 m is displayed as 2 + 02.0 m. This display option is used in Brazil but may have application in other markets.</p>
Station index increment	If the <i>Station display</i> is set to <i>Station index</i> the <i>station index increment</i> field appears enabling an appropriate station index increment to be entered. See details above.
Grade	<p>Grade</p> <p>The grade of a slope can be displayed as an angle, percent, or ratio. The ratio can be displayed as <i>Rise:Run</i> or <i>Run:Rise</i>.</p> 

This setting	Specifies how the following values are displayed
Area	Supported area units include: <ul style="list-style-type: none"> • Square meters • Square miles • Square international feet • Square US survey feet • Square international yards • Square US survey yards • Acres • Hectares
Volume	Supported volume units include: <ul style="list-style-type: none"> • Cubic meters • Cubic international feet • Cubic US Survey feet • Cubic international yards • Cubic US survey feet • Acre feet • US acre-feet
Laser VA display	Laser Vertical angles Can be vertical angles measured from the zenith, or inclinations measured from horizontal.
Time format	Time

Time/Date

To set the time and date on a Trimble controller:

1. Do one of the following:

On a Trimble tablet:

- From the desktop, tap the displayed time and date at the bottom left of the screen and then tap [Change date and time settings...].

On a Trimble Slate controller and TSC3 controller:

- Press the Windows button to open the *Start* menu and then tap [Settings / Clock and Alarms].

On a TSC2 controller:

- Press the Windows button and select [Settings / System / Clock and Alarms].

On a Trimble CU controller:

- Double-tap the clock on the right of the taskbar.

On a Geo7X/GeoXR controller:

- From within the Trimble Access menu, tap the Trimble button, select *Start Menu* and then tap [Settings / Clock and Alarms].

2. Change the date and time as required. Press **Enter** to accept the new settings or **Esc** to cancel.

To configure the GPS time display setting:

1. From the main menu, select *Jobs / Properties of job / Units*.
2. In the *Time format* field, select the required time display format.

A time stamp is stored with every record in the job and output to the DC file every 30 minutes.

Cogo settings

To configure the Cogo settings, tap *Job / New job / Cogo settings* when creating a new job. For an existing job tap *Job / Properties of job / Cogo settings*.

Use *Cogo settings* to configure:

- [Distance display](#) (grid, ground, or ellipsoid)
- [Sea level \(ellipsoid\) correction](#)
- [Increasing grid coordinate direction](#)
- [South azimuth](#)
- [Neighborhood adjustment and weight exponent](#)
- [Magnetic declination](#)
- [Advanced Geodetic](#)
- [Averaging](#)

Distance display

The *Distances* field defines how distances are displayed and which distances are used for calculations in the General Survey software. Select one of the following options:

- Ground (the default setting)
- Ellipsoid
- Grid

The following diagram shows the options between points A and B.

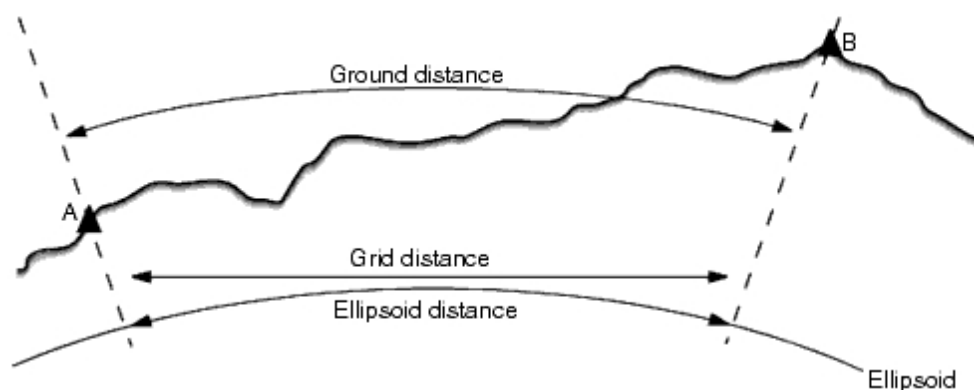

Ground distance

A ground distance is the horizontal distance calculated between the two points at the mean elevation parallel to the chosen ellipsoid.

If an ellipsoid has been defined in the job and the *Distances* field is set to *Ground*, the distance is calculated parallel to that. If no ellipsoid has been defined, the WGS84 ellipsoid is used.

Ellipsoid distance

If the *Distances* field is set to *Ellipsoid* then a correction is applied and all distances are calculated as if on the local ellipsoid, which usually approximates to sea level. If no ellipsoid has been specified, the WGS84 ellipsoid is used.

Note - If the coordinate system for a job is defined as *Scale factor only*, ellipsoid distances cannot be displayed.

Grid distance

If the *Distances* field is set to *Grid*, the grid distance between two points is displayed. This is the simple trigonometrically distance between the two sets of two-dimensional coordinates. If the coordinate system for the job is defined as *Scale factor only*, and the *Distances* field is set to *Grid*, the General Survey software displays ground distances multiplied by the scale factor.

Note - A grid distance between two measured GNSS points cannot be displayed unless you have specified a datum transformation and a projection, or performed a site calibration.

When you select *Scale factor only* in a conventional instrument only survey, grid and ground distances can be displayed.

Curvature correction

In the General Survey system, all ellipsoid and ground distances are parallel to the ellipsoid.

Sea level (ellipsoid) correction

The *Sea level (ellipsoid) correction* check box enables you to choose whether or not the horizontal components of distances measured with a conventional total station should be corrected to their equivalent length on the ellipsoid.

In most cases, select the *Sea level (ellipsoid) correction* check box to compute the correct geodetic grid coordinates from the total station observations.

However, if the local ellipsoid was inflated to provide computed ground coordinates, but the point heights were not changed to be in terms of the inflated ellipsoid, do not select sea level correction; for example, when using jobs with Minnesota county coordinate systems.

The sea level correction is carried out using the average height (not elevation) of the line above the local ellipsoid. If both ends of the line have null heights, the default height specified for the job is used to compute this correction.

The formula used for the computation is:

$$\text{Ellipsoid horizontal distance} = \text{HzDist} \times \text{Radius} / (\text{Radius} + \text{AvHt})$$

HzDist	Horizontal component of measured distance
Radius	Ellipsoid semi-major axis
AvHt	Average height above local ellipsoid of the measured line

Notes

- *In jobs where the coordinate system is configured to provide ground coordinates, the Sea level (ellipsoid) correction is always enabled and cannot be edited. This is because the sea level correction is already applied in the computation of the ground coordinates.*
- *In a Scale only job, there is no local ellipsoid available because this is not a geodetic projection. In this case, the correction computation defaults to using the semi-major axis of the WGS84 ellipsoid (6378137.0 m) as the radius value. The sea level correction in Scale only jobs also uses the point elevations because there are no ellipsoidal heights available.*
- *You cannot set a default height for Scale only jobs. This means that if the Sea level (ellipsoid) correction is enabled in a Scale only job, you must use 3D points, or null coordinates will be computed because it is not possible to compute the sea level correction.*

Grid coordinate direction

Use the *Grid coords* field to set the grid coordinates to increase in one of the following sets of directions:

- north and east
- south and west
- north and west
- south and east

The following diagram shows the effect of each setting.

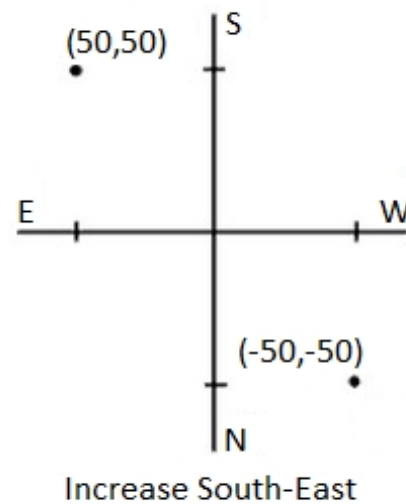
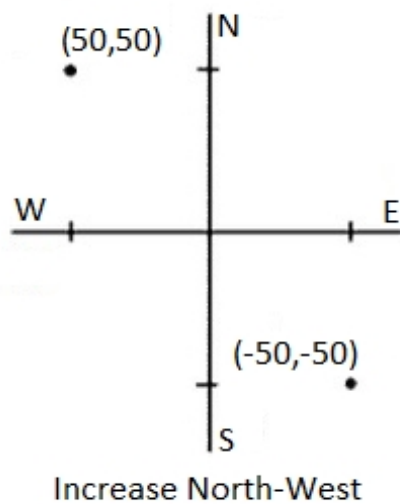
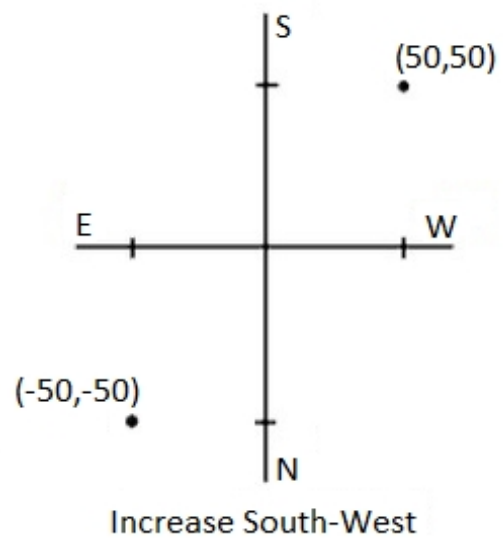
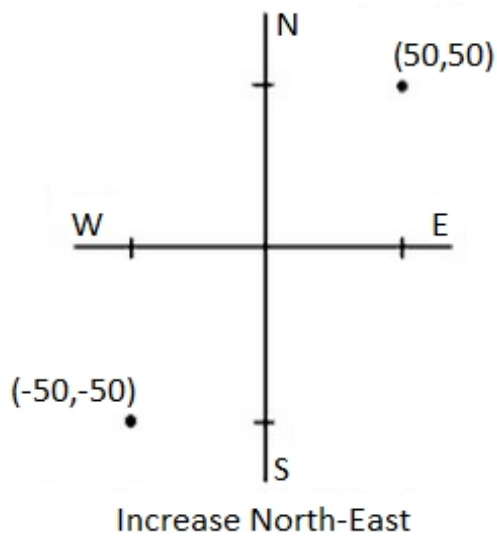

Azimuth display

The azimuth displayed and used by the General Survey software depends on the coordinate system that you defined for the current job:

- If you defined both a datum transformation and a projection, or if you selected *Scale factor only*, the grid azimuth is displayed.

- If you defined no datum transformation and/or no projection, the best available azimuth is displayed. A grid azimuth is the first choice, then a local ellipsoidal azimuth, then the WGS84 ellipsoid azimuth.
- If you are using a laser rangefinder, the magnetic azimuth is displayed.

If a south azimuth display is required, set the *South azimuth* field to *Yes*. All azimuths still increase clockwise. The following diagram shows the effect of setting the *South azimuth* fields to No or Yes.

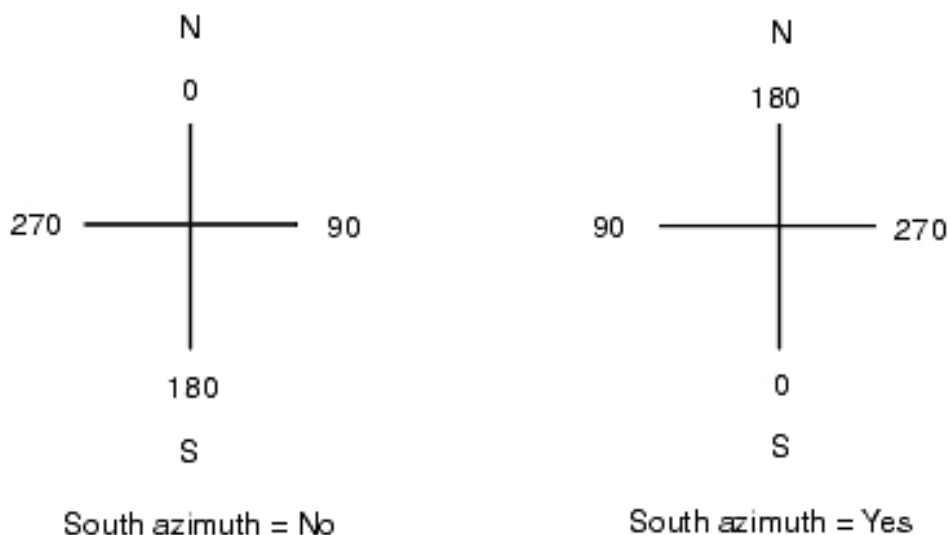

Neighborhood adjustment

You can apply a *Neighborhood adjustment* to all conventional foresight observations made from a Station setup plus or Resection, and to all GPS observations made in a job that has a valid GPS site calibration. To apply Neighborhood adjustment, select the check box in *Properties of job / Cogo settings*.

Neighborhood adjustment uses the residuals from *Station setup plus*, *Resection* or *GNSS site calibration* to calculate delta grid values to apply to subsequent observations made during the survey. Each observation is adjusted according to its distance from each of the backsight points (for a conventional survey) or calibration points (for a GNSS survey). The following formula is used to calculate the weight to give the residuals of each backsight or calibration point:

$$p = 1/D^n \text{ where:}$$

p is the weight of the backsight or calibration point

D is the distance to the backsight or calibration point

n is the weight exponent

A weighted average is then computed and the resulting delta values are applied to each new observation to get an adjusted grid position.

Note - A high value for the weight exponent results in low impact (weight) of distant backsight or calibration points.

For *Neighborhood adjustment* to be applied, the station setup or calibration must have at least 3 known points with 2D grid residuals. That is, if you perform a:

- Station setup plus, you must have HA VA SD observations to at least 2 backsight points, each with known 2D coordinates.
- Resection, you must have HA VA SD observations to at least 3 backsight points, each with known 2D coordinates.
- Calibration, you must have GNSS observations to at least 3 control points, each with known 2D coordinates.

Notes

- *Neighborhood adjustment will use a GNSS site calibration only if it has been observed in the current General Survey job. This is because a GNSS calibration that is part of the coordinate system in an uploaded job does not include the GNSS calibration residuals.*
- *For Station setup plus, the known station coordinate is included in the neighborhood adjustment calculation. In the calculation, the station coordinate is given grid residuals of zero.*
- *Neighborhood adjustment is a 2D-only adjustment. Any vertical residuals from station setup or calibration are not used in the neighborhood adjustment calculations.*
- *Neighborhood adjustment using GNSS site calibration residuals is applied to all WGS84 points in the job, not just GNSS observations.*

WARNING - Make sure that the backsight or calibration points are around the perimeter of the site. Do not survey outside the area enclosed by the backsight or calibration points (and for Station setup plus, the station point). The neighborhood adjustment is not valid beyond this perimeter.

Magnetic declination

Set the magnetic declination for the local area if magnetic bearings are being used in the General Survey software. You can use magnetic bearings if you choose the *Cogo / Compute* point using the Brng-dist from a point method.

The magnetic declination defines the relationship between magnetic north and grid north for the job. Enter a negative value if magnetic north is west of grid north. Enter a positive value if magnetic north is east of grid north. For example, if the compass needle points 7° to the east of grid north, the declination is +7° or 7°E.

Note - Use the published declination values if available.

Note - If grid north in the job has been rotated away from true north due to the coordinate system definition (possibly via a GNSS calibration) then this must be allowed for in the magnetic declination specified.

Advanced Geodetic

Select *Advanced Geodetic* to enable the following options:

- [Station setup scale factor](#)
- [Helmert transformation for Resection](#)

- [Local transformations](#)
- [SnakeGrid](#)

Averaging

The *Averaging* field defines how duplicate points are averaged. Select one of the following options:

- Weighted
- Unweighted

See [Compute average](#) for further details on weighted averaging.

CAD toolbar

The CAD toolbar enables you to measure feature codes and to edit coded line work from within the map. It is available on tablet controllers only.

Note - The CAD toolbar is not available when using the 3D map. To use the CAD toolbar, turn off the 3D map. To do this, in the 3D map tap the *Options* softkey and then clear the 3D map check box. Tap *Accept*. The map now shows the classic 2D map, with the CAD toolbar available.



To access the toolbar, do one of the following. The toolbar appears on the left side of the screen.

- Tap and hold on the map screen and then select *CAD toolbar* from the shortcut menu.
- In the map, tap *Options* and then select the *CAD toolbar* check box.

The CAD toolbar has two modes of operation:

- [Measure mode](#)
- [Drawing mode](#)

To change between modes, tap the appropriate button at the top of the CAD toolbar.

Button	Function
	Switch to measure mode.
	Switch to drawing mode.







Notes

- The CAD toolbar requires a [Feature code library](#) with line and control codes:
 - To measure or draw lines and arcs, the feature code library must have control codes for *Start join sequence* and *Join to named point*.
 - To measure or draw arcs, the feature code library must have control codes for *Start tangential arc* and *End tangential arc*.
 - To add arcs using feature codes, the points comprising the arc must have been observed consecutively. It will therefore not always be possible to join points with arcs.

Measure mode

Measure mode enables you to measure feature codes including points, lines, and tangential arcs. By using the appropriate CAD buttons with a suitable feature code library selected, you can add line work to the map and the line work will update with respect to the line and control codes in the feature code library.

The following functions are supported:

Button	Function
	Measure a point feature.
	Measure a line feature.
	Start a new line / arc sequence.
	Start an arc.
	End an arc.
	Close a last measured line / arc sequence.
Code name	Set a feature code.
Point name	Set the next point name.

Measuring a point

1. Tap the *Point* feature button.
2. If a point feature code is not already set, the feature code list appears showing all point features.
Select a feature code from the list. This code is now set as the default point feature code.
Alternatively, tap the feature code button and then set a code.
3. Tap *Measure*.

Measuring a line

1. Tap the *Line / Arc* feature button.
2. If a line feature code is not already set, the feature code list appears showing all line features.
Select a feature code from the list. This code is now set as the default line feature code.
Alternatively, tap the feature code button and then set a code.
3. Tap *Measure*. Once the point is stored, this begins or continues a line sequence.

Measuring an arc

1. Tap the *Line / Arc* feature button and then make sure that a line feature code is set.
2. Tap *Start Arc*.
3. Tap *Measure*. Once the point is stored, *Start Arc* returns to an unselected state.
4. Continue to measure line features until you reach the end point of the arc.
5. Tap *End Arc*.
6. Tap *Measure*. This last stored point ends the arc and *End Arc* returns to an unselected state.

Note - To measure the transition point between two back-to-back arcs, tap both the *Start arc* and *End arc* buttons before measuring.

Closing the last measured line / arc sequence

Tap *Close* after measuring the last point in the line / arc sequence. The line / arc sequence closes back to the first point in the line / arc sequence. It does not close to a line / arc added by the drawing mode.

Tip - It is recommended that you close a figure immediately after measuring the last point.

Starting a new line / arc sequence

1. Tap the *Line / Arc* feature button and then make sure that a line feature code is set.
2. Tap the *Start new sequence* button.
3. Tap *Measure*. Once the point is stored, the previous line / arc sequence ends and a new line / arc sequence begins.

Setting the current feature code

Tap the *Feature code* button to select the current point or line feature code from the list.

Note - If the job uses descriptions, select the *Feature code* button to access a form that enables you to enter codes and descriptions.

Tip - You can also set the current feature code by selecting a point or line feature in the map that has the required feature code and then tapping the *Feature code* button.

Setting the next point name





1. Tap the *Point name* button.
2. Enter the next point name and then tap *Accept*.

Drawing mode

Drawing mode enables coded line work to be manually added. This includes lines, arcs, and back-to-back arcs. You can also delete line work.

If a suitable feature code library is selected, line work can be added to or deleted from the map and the line work will update with respect to the line and control codes in the feature code library.

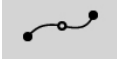
The following functions are supported:

Button	Function
	Draw a line feature.
	Draw an arc feature.
	Start a new line / arc sequence.
	Start second arc of a back-to-back arc.
	Delete a line or arc feature.
Code name	Set the feature code.
Point name	Set the next point name.

Drawing a line feature

1. Tap the *Add line* button.
2. Make sure that a line feature code is set appropriately.
3. In the map, tap the start point of the line sequence you want to create.
4. Continue to tap points until the line sequence is complete. As you select each subsequent point, a line is drawn between the two selected points and the first point is then deselected.

Drawing an arc feature

1. Tap the *Add arc* button.
2. Make sure that a line feature code is set appropriately.
3. In the map, tap the start point of the arc you want to create.
4. Continue to tap points until the arc sequence is complete. As you select each subsequent point, an arc is drawn from the first point using all subsequently selected points. As the arc is drawn the previous point is deselected.

Note - To draw a back-to-back arc, tap the *Back-to-back arc* button after completing the first arc and before selecting the second point of the second arc. After the first part of the arc is drawn between the first and second points of the arc, the button returns to the unselected state.

Starting a new line / arc sequence

1. Tap the *Line* feature button and then make sure that a line feature code is set.
2. Tap the *Start new sequence* button.
3. In the map, tap the start point for the line / arc you want to create. The previous line / arc sequence ends and a new line / arc sequence begins.

Deleting line work

1. Select the elements that you want to delete.
2. Tap the *Delete* button.
3. Select the feature(s) to delete from the list and then tap *Enter*.

Setting the current feature code

Tap the *Feature code* button to select the current point or line feature code from the list.

Note - If the job uses descriptions, selecting the *Feature code* button brings up a form that enables you to enter the code and descriptions.

Tip - You can also set the current feature code by selecting a point or line feature in the map that has the required feature code and then tapping the *Feature code* button.

Setting the next point name

1. Tap the *Point name* button.
2. Enter the next point name and then tap *Accept*.

Offset line

You can offset a line:

- horizontally
- vertically
- horizontally and vertically

Note - This function is available only from the Map.

To offset a line:

1. From the Map, select the line to offset.
2. Tap and hold briefly on the map and then select *Offset line* from the menu.
3. Specify the offset value(s): Use the pop-up arrow to select the appropriate offset direction.
4. Tap *Store*.

Compute intersection

You can compute and store points at the intersection of:

- two points and a line
- two lines
- two arcs
- two points and an arc
- a line and an arc

Note - This function is available only from the Map.

To compute an intersection:

1. From the Map, select the entities to intersect.
2. Tap and hold briefly on the map and then select *Compute intersection* from the menu.
3. Optionally, enter a horizontal and/or vertical offset for each entity: Use the pop-up arrow to select the appropriate offset direction.
4. Select how the elevation for the intersection point will be calculated. Options vary depending on the entities selected but can include:
 - None - the elevation will be null
 - Line/Arc 1 - the elevation is computed using the grade of the first line/arc
 - Line/Arc 2 - the elevation is computed using the grade of the second line/arc
 - Average - the average of the elevations is computed using the grade of the first and second line/arc
5. Tap *Calc.*
6. Complete the fields and then tap *Store.*

Notes

- *The horizontal offset direction is relative to the selected direction of the entity.*
- *When one or both entities are an arc, two intersections may be computed. Both can be stored but if you don't want to store the first point, tap Skip.*

Using a feature library

To select a code in a survey, first select the library that you want to use:

1. From the main menu, select *Jobs / Properties of job.*
2. Tap the *Feature library* button and select the library that you want to use.

Note - *Feature libraries cannot be used in Description fields.*

To choose a code from the library:

1. In the *Code* field, enter the first character of the required feature code. The feature code list is filtered according to the type of controller that you are using and the Auto-complete setting:

Trimble controller	Auto-complete on	Auto-complete off
TSC3/TSC2/Geo7X/GeoXR /Slate/Trimble tablet	The feature code list is always filtered according to the characters that you enter. When you type a character, the first available code that starts with that character appears.	The feature code list is always filtered according to the characters that you enter. Only the character that you enter appears and is used to filter the feature code list.
Trimble CU	You do not need to put the controller into alpha mode to select an alpha code. The feature code list is filtered according to the characters available on the controller key that you pressed. For example, if you press "2", the list is filtered on a "2", and the associated keypad characters "T", "U", and "V". The first available code that starts with one of these characters appears.	The General Survey software maintains the alpha or numeric setting. Only the character that you enter appears and is used to filter the feature code list.

- To further filter the feature code list, enter additional characters. Use the arrow keys to scroll to the required code, or if the required code is already displayed, tap *Enter* to accept this code and move to the next field.

Tip - Tap the *Name* or *Description* heading to sort the codes by that column.

When you select a code from the list, filtering is disabled and the entire feature code list appears, which allows you to select another code.

To enter multiple codes, select each code in turn from the list. As you select multiple codes from the list, the system automatically enters a space to separate the codes. If you enter codes through the controller keypad, you must enter a space after each code to display the entire code list again before you enter the next code.

Note - An individual Feature code cannot contain more than 20 characters. But the maximum number of characters in a code field is 60.

Note - If a feature code list is already selected for the job, you can use codes from the list when keying in a note. From the Note screen, press *Space* to display the feature code list. Select a code from the list or type the first few letters of the code.

To edit a code once a point has been measured:

- Select *Jobs / Review job* or *Jobs / Point manager*.
- Edit the code field for the point.

How to use the code field when using feature code libraries

If you use a feature library, when you access the code field on forms in the General Survey software, a *Code list* dialog appears with special controls to help you select codes from the feature code list.

To select the entire code in the code list window, click anywhere in the code field, or press the controller left or right arrow when on a code field.

Tip – A partial selection made in the code field is retained in the *Code list* dialog.

When the *Code list* dialog is active:

- To replace the code:
 - Select a code from the list when the entire code is highlighted (with an unfiltered list)
 - Select a code from the list when the highlight or cursor is within a code (with a filtered list).
- To add a code:
 - Select a code from the list when the cursor is at the start or end of a code (with an unfiltered list).

Note - Spaces are automatically entered to separate multiple codes.

Filtering in the *Code list* dialog:

- The code list is filtered according to the characters to the left of the cursor or highlight.
- If the cursor is at the beginning or end of the code field and editing is not in progress, the code list is not filtered.

Using a touch screen to replace a code:

1. Tap in the code field. The code field is highlighted.
2. Use the scroll bar to scroll to the new code and then tap to select the new code you want to replace the old code.
3. To exit the *Code selection* dialog, tap *Enter*.

Using a touch screen to add to an existing code:

1. To open the *Code list* dialog, tap in the code field.
2. To remove the highlight on the code field before you select the new code, tap at the beginning or end of the code field.

The General Survey software automatically inserts spaces to separate multiple codes.

Using a keyboard to replace code:

1. Tab or arrow to the code field.
2. Press the key representing the first character of the code. The code list is filtered on that first character.
3. Depending on the size of your code library, do one of the following:
 - If the required code is not visible, press the key(s) representing the next character(s) of your code to further filter the list.
 - If the required code is visible, arrow down to the code, press *Enter* to select the code and then press *Enter* again to exit the dialog.

Using a keyboard to add to an existing code:

1. To open the *Code list* dialog, press the right arrow.
2. To remove the highlight on the code field before you select the new code, press the right arrow again.

The General Survey software automatically inserts spaces to separate multiple codes.

Tips

- To edit an existing code, use the arrow keys to navigate to the correct position and then use the backspace key to remove unwanted characters. As the code is modified, the code list filters accordingly.
- When auto-complete is turned off, recently used codes appear at the top of the code list. Multiple entry codes are remembered as a single entry in the recently used list. This allows you to quickly select recently used codes, especially multiple code entries.
- To enter a code that is not in the library, but which has a similar entry in the library, press the space key to accept the code that you enter not the similar code from the library. Alternatively, turn off auto-complete.

Using feature codes with predefined attributes

When you use a feature code that has attributes, the General Survey software prompts you to enter the attribute data.

You can use feature libraries that were created using Trimble Office software, such as the Trimble Business Center Feature Manager. Feature codes that have attributes have an attribute icon (Ⓐ) next to the feature code in the library.

To assign an attribute to a point:

1. Ensure that a suitable *Feature library* is associated with the job. To do this, select *Jobs / Properties of job* and then tap the *Feature library* button to associate a feature library with the job. Tap *Accept*.
2. Enter the point name and select a code with attributes.
3. Tap the *Attrib* softkey and then enter the attributes of the point you are measuring
4. From the same screen, tap the *Option* softkey to select the default attribute behavior. Choose from:
 - *Last used*
 - *From library*

Note – When measuring a point, tap *Options* and select *Prompt for attributes* to make the attribute form appear each time there are required attributes for which no value has yet been entered. However, note that:

- If you pre-entered attributes using the *Attrib* softkey, you are not prompted for attributes.
- If the attribute is set as a required attribute in the feature code library and does not have a default value set in the feature code library, then even if *Prompt for attributes* is not selected the attribute form is displayed to ensure the attributes are collected. To avoid being prompted for attributes when you have not selected the *Prompt for attributes* check box you

must make sure required attributes have a default value set in the library or set the default attribute behavior to Last used.

Resurveying points that already have attributes

To stake out and re-measure points for which you already have attribute data:

1. If the job is not yet in the General Survey software, transfer it from the Trimble Business Center software.
Note - Transfer relevant features and attributes as well as the points.
2. From the main menu, tap *Stakeout* / *<Style name>* / *Points*.
3. Tap *Options* and from the *As-staked point details* group, set the *As-staked code* field to *Design code*.
4. Stake out the point.
5. Measure the as-staked point.

The attribute data displayed for the point is the attribute data that you entered previously. The defaults in the feature library are not used. Update the values as required.

Additional settings

To configure the additional settings, tap *Job* / *New job* / *Additional settings* when creating a new job. For an existing job tap *Job* / *Properties of job* / *Additional settings*.

Use *Additional settings* to configure:

- [Descriptions](#)
- [Feature library](#)
- [Point name range for the job](#)
- [Add to CSV file](#)

Descriptions

You can choose to display two additional description fields in many functions within the General Survey software.

The description fields are similar to code fields because they enable you to add additional information to data. They do not use feature code libraries, and they do not support attributes.

The description field data is available in Trimble DC files as Note records.

You can also use [Export fixed format files](#) or [Export custom format files](#) to export the data stored in the description fields.

To enable and customize the description fields:

1. From the main menu, select *Jobs* / *Properties of job*.
2. Tap the *Descriptions* button.
3. Select the *Use descriptions* check box.

4. If required, enter a new name for *Description 1 label* and *Description 2 label*.
5. Tap *Accept*.

Once the additional descriptions fields are enabled, they are available in the following features of the General Survey software:

- Station setup
- Measure topo
- Measure codes
- Continuous topo
- Stakeout
- Point manager
- Review job
- Key in point, line, and arc
- Compute point
- Compute average
- Transformations
- Traverse
- Wildcard search

Each of the two description fields remembers the descriptions that are entered. To view the stack of previously used descriptions, tap the arrow on the description field.

The description stack is unique for each description field. The description stack is stored to the [descriptions.xml] file in the [System files] folder on the controller. You can edit it with a text editor, and copy it to another controller.

Point name range for the job

To specify a minimum and maximum point name for the job, select the *Apply point name range* check box and then enter the required point names.

Note – *The point names must be numeric. Numbers that include decimal points or alphabetic characters are ignored. Negative and positive numbers are supported.*

Feature library

Select the *Use attributes of base code* check box to provide attributes for the complete code, or from a portion of the code - the "base code". This setting is applied throughout the General Survey software, including [Measure codes](#).

Attributes and base codes

Typically, base codes are used when you use the '+' and '-' softkeys to "string" feature codes. For example, when you code a fence where all observations coded "Fence01" are joined together and all observations coded "Fence02" are joined together, and so on, and they all have the same attributes. In this example, you can create feature code libraries that contain all the "Fence**" codes, or contain just the base code "Fence".

If you do not string codes, or if you do string codes but you include the entire code in the feature code library, then you are not using base codes. Disable *Use attributes of base code* (clear the check box).

If you do string codes, and the feature library includes only the base code, then enable *Use attributes of base code* (select the check box).

In the General Survey software, you can use the extra power of [Measure codes](#) to create a button that contains a numeric or alpha-numeric code (the base code) and then append a numeric suffix using the + or - softkeys. For codes entered into any other code field in the General Survey software, you cannot use the + or - softkeys to append a suffix, so when you use base codes, the software can only attempt to determine the base code by stripping the numeric characters from the end of the codes.

The following rules help to explain the base code:

- When *Use attributes of base code* is disabled, the code entered is the base code.
- When *Use attributes of base code* is enabled, the base code is determined by internally stripping any numeric characters from the end of the code.
- When *Use attributes of base code* is enabled and you edit a code that is passed from Measure codes, the base code is re-derived by internally stripping any numeric characters from the end of the code.

Add to CSV file

You can choose to add points measured using [Measure topo](#) or [Measure rounds](#) to a CSV file. To do this:

1. Select the *Enable* option.
2. In the *CSV file name* field, enter a file name or use the folder button to select a file. By default, the CSV file is stored in the current user folder.

Tip - This option can be used to create a file of control points.

Media files

Media files, for example images, can be:

- Uploaded as a [file](#)
- Captured using the [internal camera](#) in the following controllers:
 - Trimble TSC3
 - Trimble Slate controller
 - Trimble Geo7X
 - Trimble GeoXR
 - Trimble tablet
- Captured using an instrument that has [Trimble VISION technology](#)
- Captured using a [digital camera](#) including the:

- Ricoh Caplio 500SE-W via Wi-Fi
- Ricoh Caplio 500SE-W via BlueTooth
- SDHC compatible digital camera via Wi-Fi

Media files can be linked to:

- An **attribute**. The media file name is automatically entered into the *File name attribute* field if an image is captured using:
 - The internal camera in the following controllers:
 - Trimble TSC3
 - Trimble Slate controller
 - Trimble Geo7X
 - Trimble GeoXR
 - Trimble tablet
 - An instrument that has Trimble VISION™ technology
 - A digital camera including the:
 - Ricoh Caplio 500SE-W via Wi-Fi
 - Ricoh Caplio 500SE-W via BlueTooth
 - SDHC compatible digital camera via Wi-Fi
 - or when a .jpg/.jpeg image is added to [\\My Documents] on the controller.
- A **job**
- A **point** in a job

You can **draw** on media files to add additional information.

Note - Images captured with an instrument that has Trimble VISION™ technology are saved to the **<jobname> Files** folder. Images captured using the controller's built-in camera or a digital camera are typically saved to the My Pictures folder. For some devices the location these files are saved to can be changed, but Trimble recommends you save the files to the My Pictures folder. The Trimble Access software monitors the My Pictures folder and moves images saved to the My Pictures folder to the **<jobname> Files** folder. If the files are saved to another location, the software cannot detect the arrival of new files and cannot move them. Storing all the images in the current **<jobname> Files** folder facilitates download with Trimble Business Center and AccessSync, and also makes linking the images to a point, a job, or an attribute possible.

Geotagging an image

Geotagging is the process of adding geographical identification metadata to various media such as images. Metadata includes WGS-84 latitude, longitude, and height, that is written to the EXIF header of the image (EXIF = EXchangeable Image File format). The geotagged image can be used in the Trimble Business Center, Trimble Connected Community, and third-party applications. Geotagging is assigned to jpeg images linked as a file or image attribute or media file to a point. This requires the job to have a coordinate system.

The position written to the image is provided using either the:

- [On-board GPS of the controller](#)
- [GNSS receiver, or conventional instrument, connected to the controller](#)

Geotagging using the on-board GPS of the controller

Geotagged is supported for positions captured using the on-board GPS for the following controllers:



- Trimble TSC3
- Trimble Slate controller
- Trimble tablet

Note - Although the Geo7X/GeoXR has on-board GNSS, images can only be geotagged with a position captured using a connected Trimble GNSS receiver. See [below](#) for details.



Enabling geotagging for a Trimble TSC3

1. Press (Fn + 1).
2. Tap [Menu] scroll down and select [Geotagging]
3. Configure the [Geotagging], [GPS Power] and [Font] settings. For further information, refer to the TSC3 controller manual. Geotagging can either be to the Exif header, text on the image or both.
4. Tap [OK] twice.

Enabling geotagging for a Trimble Slate controller

1. From the General Survey menu, tap *Instruments / Camera*.
Tip - To be able to access the camera from anywhere within Trimble Access, add a command to the [Favorites](#) list or customize an [App](#) button.
2. Tap the screen and then tap the up arrow  to display the pop-up menu.
3. Tap  to access the camera settings and then  to access the [Image tagging] menu.
4. Select [Date] and [GPS] to configure geotagging. For further information, refer to the Trimble Slate controller manual.
5. Tap [X] to save your configuration and exit.

Enabling geotagging for a Trimble tablet

1. From the General Survey menu, tap *Instruments / Camera*.
Tip - To be able to access the camera from anywhere within Trimble Access, add a command to the [Favorites](#) list or customize an [App](#) button.
2. Tap the screen and then the up arrow  to display the pop-up menu.
3. Tap  to access the camera settings and then  to access the [Image tagging] menu.
4. Select [Date] and [GPS] to configure geotagging. For further information, refer to the documentation for your Trimble tablet.
5. Tap [X] to save your configuration and exit.

Geotagging using a GNSS receiver or conventional instrument connected to the controller

To configure geotagging using the position from a GNSS receiver or conventional instrument connected to the controller, do the following:

1. From the General Survey menu, select *Jobs / Properties of job*.
2. Tap the *Media file* button.
3. Select *Geotag images*. Geotagging is only supported for images linked to the *Previous point*, *Next point* or *Point name*.
4. Tap *Accept*.

To enable geotagging:

1. Enter a feature code with a file attribute and then tap *Attrib*.
2. Tap the *Options* softkey and then select *Geotag images*.

To geotag an image after it has been added to a point:

1. Add another image, tap *Store* and then tap *Accept*.
2. Add a previous image, select geotagging, tap *Store* and then tap *Accept*.

It is not possible to remove geotagging information from an image.

Notes

- *Activating geotagging within Trimble Access does not activate geotagging in the operating system for the built-in camera(s) in the TSC3, Geo7X, GeoXR, Slate, and Trimble tablet.*
- *If you are using a digital camera that supports geotagging, and geotagging within Trimble Access is not activated, the metadata added to the image will be at the position of the camera, not at the measured point.*
- *If you are using a digital camera that supports geotagging and geotagging within Trimble Access is activated, the metadata added to the image will be at the position of the measured point, not at the camera.*

Drawing on an image

The *Draw* option is available when viewing a .jpg or .jpeg image in:

- *Jobs / Review job*
- the *Video* screen after capturing the image using the *Snapshot* option

Note – *HDR images or images captured using a Trimble V10 imaging rover cannot be drawn on.*

To draw on an image:

1. Tap *Draw*.
2. To pre-configure the line width, style, and color or the text color, background color, and size, tap *Options*.

3. From the *Draw* tool bar select the appropriate option to draw items on the image:

- freehand line work
- lines
- rectangles
- ellipses
- text

To split text onto a new line, press **Shift + Enter** or **Ctrl + Enter**.

Up to 10 undo actions are supported.

Immediately after drawing an item on the image you can:

- Tap and hold on the item and then drag it to a new position on the image.
- Select *Options* and change the line width, style, and color or the text color, background color, and size of the item.

4. To save a copy of the original image to the **<jobname> Files\Original Files** folder, tap *Options* and select *Save original image*.

Note – If you do not have a job open, images are saved to the current project folder and original images are saved to the **Original Files** folder inside the current [project folder](#).

5. Tap *Save*.

To view the original image in the *Review Job* screen, tap *Original*. To return to the edited image, tap *Modified*.

Using a camera to capture an image

Images can be captured using the:

- [Trimble TSC3](#)
- [Trimble Slate controller](#)
- [Geo7X/GeoXR](#)
- [Trimble tablet](#)
- An instrument that has [Trimble VISION technology](#)

Images can also be captured using a digital camera including the:

- [Ricoh Caplio 500SE-W via BlueTooth](#)
- [Ricoh Caplio 500SE-W via Wi-Fi](#)
- [SDHC compatible digital camera via Wi-Fi](#)

By default, images are saved to the **<jobname> Files** folder. If you do not have a job open, images are saved to the current [project folder](#).

To specify a different folder for images transferred via Wi-Fi, select *Settings / Connect / Wi-Fi image transfer*.



Tips

- Media files (images) captured using a separate digital camera, or the controller or instrument's integrated camera can be:
 - linked to an attribute, the job, or a point in a job. See [Linking media files](#).
 - drawn on in *Jobs / Review job*. See [Drawing on an image](#).
- To be able to access the camera from anywhere within Trimble Access, add a command to the *Favorites* list or customize an *App* button.

Using the TSC3 controller to capture images

1. Press (Fn + 1) or from the General Survey menu, tap *Instruments / Camera*.
2. Tap *Menu* and configure the various camera settings, if required. By default, the camera resolution is set to the second lowest value. You may want to change this setting to obtain better-quality images.
The zoom factor values that appear depend on the selected resolution. For more information, refer to the TSC3 controller documentation.
3. Position the controller to capture the required image and then press the trigger key (the Enter key on the controller's navigation pad) lightly to focus and then complete the press to capture the image.
4. To close the camera, tap *OK* twice.



Using the Trimble Slate controller to capture images

1. From the General Survey menu, tap *Instruments / Camera*.
2. Tap the screen and then the up arrow  to configure the various camera settings, if required. For more information, refer to the Trimble Slate controller documentation.
3. Position the controller to capture the required image and then tap the camera button  to capture the image.
4. To close the camera, tap the screen and then tap [X].



Using the Geo7X/GeoXR to capture images

1. Press the camera button or from the General Survey menu, tap *Instruments / Camera*.
2. Tap *Menu* and configure the various camera settings, if required. The zoom factor values that appear depend on the selected resolution. For more information, refer to the Geo7X/GeoXR controller documentation.
3. Position the controller to capture the required image and then press the camera button to focus and then release to capture the image.
4. To close the camera, tap *OK*.

Using the Trimble tablet to capture images

1. From the General Survey menu, tap *Instruments / Camera*.
2. Tap the screen and then the up arrow  to configure the various camera settings, if required. For more information, refer to the Trimble tablet documentation.
3. Position the controller to capture the required image and then tap the camera button  or the *OK* button on the controller to capture the image.
4. To close the camera, tap the screen and then [X].

Using an instrument that has Trimble VISION technology to capture images

1. Connect to the instrument.
2. To access the Video option do one of the following:
 - From the main menu, tap *Instrument / Video*.
 - Tap the Instrument icon in the status bar and then tap *Video* in the *Instrument functions* screen.
3. Tap the Settings button  to set the photo properties, if required. See [Video](#) for more information.
4. Tap the Snapshot button  to capture the image.
5. Tap *Store* to store the image.

See [Video](#) for a description of Trimble VISION technology.

Supported wireless cameras

With some brands of digital camera, you can take images and then wirelessly transfer them to the controller.

You can use Bluetooth or Wi-Fi technology for wireless transfer of images. A Wi-Fi connection can be more difficult to set up but offers faster file transfer. A Bluetooth connection is generally easier to set up but file transfer is slower.

Camera	Wireless technology	Protocol
Ricoh Caplio 500SE-W	Wi-Fi	FTP
Ricoh Caplio 500SE-W	Bluetooth	Bluetooth
SDHC compatible digital camera	Wi-Fi	Eye-Fi

You can connect a [controller that has Bluetooth wireless technology](#) to a Bluetooth capable digital camera, or connect a [controller that has Wi-Fi technology](#) to a Wi-Fi capable digital camera.

If the image does not transfer within a few minutes, turn off the camera and then turn it on again. This will cause the Eye-Fi SDHC card to restart the transfer process.

To use a Wi-Fi connection to a camera and an Internet connection via Bluetooth to an external phone at the same time, you must first create the Internet connection (using Internet Setup) and then create the connection to the camera

Setting up the Ricoh Caplio 500SE-W using a Bluetooth connection

For optimal file transfer through a Bluetooth connection, make sure that the correct settings are configured on the camera:

1. Press [Menu/OK] while in shooting mode to view the shooting settings [SHTG STGS] menu.
2. Press the right arrow to select the expanded settings [EXP SET] menu.
3. Press the up or down arrows to ensure that the menu items are configured as follows:

Menu item	Setting
BT Auto Conn	Off
Master/Slave	Master
Image File Size	160
Auto Del	Off
Quick Send Mode	2 Touch
Change COM	BT

Tip - Transferring large images through a Bluetooth wireless connection can be slow. For faster file transfer from the camera to the controller, set the [Image File Size] to the smallest value. This transfers a small image with the same name as the original file to the controller, enabling you to link the image correctly to your job. When in the office, copy the files from the camera into the **<jobname> Files** folder, overwriting the images that were transferred from the controller. **Do not** change the image names on the controller. If you set [Quick Send Mode] to [1Touch], the [Image File Size] setting does not apply and the full-sized image is transferred, making the transfer slower.

Setting up a Wi-Fi connection between the controller and camera

- For more information, refer to the support note *Trimble Handhelds Running Windows Mobile Version 5.0 Software: Connecting a Ricoh Caplio 500SE-W Camera*.

Configuring a Trimble tablet to work with an SDHC compatible digital camera

Note - Wi-Fi image transfer may not work on non-Trimble tablet computers. For more information, refer to the documentation provided with your computer.

To communicate with an SDHC-compatible digital camera, you must select Wi-Fi image transfer when installing the Trimble Access software using the Trimble Access Installation Manager. As the Wi-Fi image transfer software and license are installed, a configuration wizard configures and pairs the Eye-Fi card to the controller. However, as your Wi-Fi connection may be used for Internet access, you must manually configure the Wi-Fi setting each time you switch between transferring images and Internet use.

To manually switch to the Wi-Fi image transfer network:

1. From the main Trimble Access menu, tap *Settings / Connect / Wi-Fi image transfer*.
2. If the *User Account Control* dialog appears, tap *Yes*.
3. From the Wi-Fi image transfer screen, select the *Settings* tab.
4. Tap *Wi-Fi networks* to open the *Network and Sharing Center* dialog.

5. Tap *Connect or disconnect* or *Connect to a network* (if no connection has been established). From the pop-up list of wireless network connections, select the serial number of your Trimble tablet.
6. Tap *Connect* to switch to the Wi-Fi image transfer network.
7. Close the *Network and Sharing Center* dialog.
8. From the *Wi-Fi adaptor mode* drop down list, select *Connect to ad-hoc network*.
9. Close *Wi-Fi image transfer*. When the *Set network location* dialog appears, select *Public*.
You are now configured to capture and wirelessly transfer images.

To return to the previous network:

1. From the main Trimble Access menu, tap *Settings / Connect / Wi-Fi image transfer*.
2. If the *User Account Control* dialog appears, tap *Yes*.
3. From the *Wi-Fi image transfer* screen, select the *Settings* tab.
4. Tap *Wi-Fi networks* to open the *Network and Sharing Center* dialog.
5. Tap *Connect or disconnect* or *Connect to a network* (if no connection has been established). From the pop-up list of wireless network connections, select the previous network.
6. To return to the previous network, tap *Connect*.
7. Close the *Network and Sharing Center* dialog.
8. From the *Wi-Fi adaptor mode* drop down list, select *Connect to infrastructure network*.
9. Close *Wi-Fi image transfer*.

Configuring a non-tablet controller to work with an SDHC compatible digital camera

To configure [non-tablet controllers that have Wi-Fi](#) to communicate with an SDHC-compatible digital camera, you must select Wi-Fi image transfer when installing the Trimble Access software using the Trimble Access Installation Manager. As the Wi-Fi image transfer software and license are installed, a configuration wizard configures and pairs the Eye-Fi card to the controller.

To enable Wi-Fi image transfer on the controller:

1. From the main Trimble Access menu, tap *Settings / Connect / Wi-Fi image transfer*.
2. From the *Wi-Fi image transfer* screen, select the *Settings* tab.
3. Tap *Turn on Wi-Fi*.
4. From the *Wi-Fi adaptor mode* drop-down list, select *Connect to ad-hoc network*.
5. Tap *Close*.

Annotating a snapshot

Use the *Annotate snapshot* option to add an information panel and crosshairs for the measured position to images captured using the *Video / Snapshot* option.

1. From the main menu, tap *Instrument / Video*.
2. Tap the up arrow and then tap *Options*.

3. Enable *Annotate snapshot* and then:
 - Select the items from the *Annotate options* group to display in the information panel at the bottom of the image.
 - Select the *Crosshair* checkbox to add the crosshair for the measured position.
4. To save a copy of the original image to the **<jobname> Files\Original Files** folder, select *Save original image*.

Tip – The information panel is not displayed when the image is captured. To view the information panel, go to *Review job* and select the image.

Notes

- The *Annotate snapshot* check box is available only if the *Snapshot on measure* check box is enabled.
- To display descriptions in the information panel, select the *Descriptions* item and then go to *Job properties* and select *Use descriptions and define the description labels* in the [Additional settings](#) screen.
- If you do not have a job open, images are saved to the current [project folder](#) and original images are saved to the **Original Files** folder inside the current project folder.

Linking media files

Media files can be linked to:

- An [attribute](#)
- A [job](#)
- A [point](#) in a job

Linking media files to an attribute

Use the *File name attribute* field to link a file name to an attribute. You can use file name attributes for any type of file, but typically when linking .jpg/.jpeg images.

The *File name attribute* field includes a **Browse** button  that enables you to:

- Find and select a file name as an attribute.
- Review a .jpg/.jpeg file that was entered into the attribute field.

The *File name attribute* field detects when an image has been captured using:

- A [Trimble controller with an internal camera](#)
- An instrument that has [Trimble VISION technology](#)
- A [digital camera](#) including the:
 - Ricoh Caplio 500SE-W via Wi-Fi
 - Ricoh Caplio 500SE-W via BlueTooth
 - SDHC compatible digital camera via Wi-Fi
- Or when a .jpg/.jpeg image is added to [My Documents] on the controller.

If an image is detected, the file name is automatically entered into the *File name attribute* field.

If there are multiple *File name attribute* fields, the filename will be entered into the highlighted field. Alternatively, tap Browse  to open a dialog and then do one of the following to select the required file:

- Tap the file.
- Use the arrow key to highlight the file and then tap **OK**.
- If selecting a .jpg/.jpeg file, tap and hold with the stylus on the file and then select *Preview*. Tap *Select* to select the current file, or tap *Prev* or *Next* to preview another file.

If you select a .jpg/.jpeg file, an option to *Review* the selected file becomes available from the Browse button. To change your selection, tap  and then tap *Select file*.

Once you select an image from a folder, it becomes the default folder the next time you select an image.

When selecting the file, the available "tap and hold" options are: Select, Preview, Cut, Copy, Paste, Rename, Delete, Create folder, and Properties.



Notes

- *You should not rename a file after attaching it to an observation. Files renamed after attaching will not be downloaded with the job.*
- *Feature codes created using the General Survey software do not have attributes associated with them.*

Tips

- To sort a column in ascending or descending order, tap the column header.
- An arrow beside the column title indicates the sort order.
- To quickly select the latest file, sort on *Modified* date and time. If the oldest files appear at the top of the list, click *Modified* again to reverse the sort order.

Using a Trimble controller with an internal camera to capture images from the attribute form

1. Enter a feature code with a file attribute and then tap *Attrib*.
If the *View before storage* check box is enabled in the *Measure point options* screen, then the attribute form automatically appears when you store the point.
2. Tap  in the attribute form to capture an image using the internal camera. Alternatively, press the appropriate button on the controller to capture the image. See [Using a camera to capture an image](#).
3. The image name is automatically entered into the file attribute field. If required, review the image; tap Browse  and then select *Review*. To save the attributes, tap *Store*.



Note - *For image names to be entered automatically, the images must be stored in the default folder location (MyPictures).*

Using an instrument to capture images

Use an instrument that has Trimble VISION technology to capture images and automatically link them to a *File name attribute* field. You can do this from the attributes form or from the video screen.

- You can use the Capture softkey  to capture images.
- You can use the *Snapshot on measure* option in the video screen to measure points and automatically add the image name to the *File name attribute* field.

Using an instrument to capture images from the attributes form

1. Connect to the instrument.
2. Enter a feature code with a file attribute and then tap *Attrib*.
3. Tap  to capture an image:
 - If the video screen is not already open, it opens now. Set the appropriate image quality and zoom settings and then capture the image. When the image is captured, tap *Store*. To return to the attribute form, tap *Close*.
 - If the video screen is open in the background, an image is automatically captured using the current video settings. When the image is captured, tap *Store*.
4. The image name is automatically entered into the file attribute field. If required, review the image; tap *Browse*  and then select *Review*. To save the attributes, tap *Store*.

Note - When measuring a point with a code that includes a photo attribute, if you selected the *Attrib* softkey before measuring and storing the point **and** you have elected to annotate the image with the grid and/or WGS coordinates, the coordinates are shown as null because the point has not yet been measured.

Using an instrument with snapshot on measure

1. Connect to the instrument.
2. From the Instrument menu tap *Video*.
3. Tap the Settings button  and:
 - Set the image properties, if required.
 - Make sure that *Snapshot on measure* is enabled.
 - To draw the instrument crosshairs on the image, select the *Crosshair* check box in the *Annotate options* group.
 - Select the color of the crosshairs in the *Overlay color* field.
 - Set the other options as required and then tap *Accept*.
4. In the video screen, aim to the target and then tap *Measure*.
5. If required, set the feature code and then tap *Attrib*. The attributes form appears and the image is automatically captured with the file name entered into the file attribute field.
 - If there are multiple *File name attribute* fields, the file name is entered into the highlighted field.

- If there are multiple codes entered for a point, an attribute form will appear for each code with attributes. The image will be captured when the first file attribute field appears.

6. Tap *Store* to save the attributes and return to the video screen.

Notes

- *If no feature code is set then the captured snapshot is assigned to the measured point.*
- *When using [AccessVision](#) and you are viewing the video display within the Measure topo screen, the snapshot on measure setting is applied. This is the same behavior as when a measurement is initiated from the Instruments / Video screen.*

Setting the default attributes option

You can configure the General Survey software to use **Last used** attributes, by default. To do this, tap *Options* (available when the attributes appear) and then set the *Default attributes* field to *Last used*.

You can configure the General Survey software to use attributes from the Feature library, by default. To do this, tap *Options* (available when the attributes appear) and then set the *Default attributes* field to *From library*.

Note - *You must first define the default attributes in the Feature library, or default values will be null.*

Using a digital camera to capture images

With some brands of digital camera, you can take images and then wirelessly transfer them to the controller. When using a feature library with file name attributes you can preview and associate the image files as attributes of a feature code.

You can connect a [controller that has Bluetooth wireless technology](#) to a Bluetooth capable digital camera, or connect a [controller that has Wi-Fi technology](#) to a Wi-Fi capable digital camera.

Sending files from the Ricoh Caplio 500SE-W camera through Bluetooth

The first time you transfer files to a particular controller:

1. Capture the image to be transferred.
2. Press [Playback] to review the image.
3. Press [MENU/OK] to view the Playback Settings Menu [PLBK STGS].
4. Press the down-arrow to access the [FILE SEND] menu.
5. Press the right arrow to view a list of Bluetooth devices available to send the image to. If there are no devices stored on the camera, the following message appears, [*The destination not registered. Search Destination?*] Select [Yes].
6. Select the controller you want to send the file to and then press [OK].
7. Select [SEND ONE] and then press [OK] to send the image.
8. The file is sent to the controller. If prompted, accept the file on the controller. Files are stored in the [\\My Device\\My Documents] folder.
9. The file name is automatically entered into the *File name attribute* field (if the attribute field has focus when the image appears). If there are multiple *File name attribute* fields, the file

name is entered into the highlighted field. Alternatively, tap Browse  and then tap *Select file*.

After you transfer one file to a controller through the Bluetooth connection, you can use the [Quick Send Mode] to send files to the same controller. For optimal file transfer, use the [2 Touch Quick Send Mode]:

1. Capture the image to be transferred.
2. Press [Quick Review].
3. Press [OK] to send the image. The camera connects to the last used Bluetooth device and then sends the image.
4. The file name is automatically entered into the *File name attribute* field (if the attribute field has focus when the image appears). If there are multiple *File name attribute* fields, the file name is entered into the highlighted field. Alternatively, tap Browse  and then tap *Select file*.

Note - When [Quick Send Mode] is set to [1Touch], the [Image File Size] setting does not apply and the full-sized image is transferred, making the transfer slower.

Setting up a Wi-Fi connection between the controller and camera

For more information, refer to the support note *Trimble Handhelds Running Windows Mobile Version 5.0 Software: Connecting a Ricoh Caplio 500SE-W Camera*.

Linking media files to a job or a point

To capture an image using a Trimble controller and then link it to the job or point in a job, do the following:

1. Use the controller to capture the image. (On any controller, from the General Survey menu, tap *Instruments / Camera*.)

Tips

- See [Cameras](#) for details on configuring the camera for each controller.
 - To be able to access the camera from anywhere within Trimble Access, add a command to the [Favorites](#) list or customize an [App](#) button.
2. If, when the [Media file](#) was configured, you selected the *Show with new media file* option, the media file screen appears showing a thumbnail of the image. This enables the [Link to](#) method to be changed and, if linking by point name, the point name.

Note – If the *Show with new media file* option was not selected, the image will be automatically linked.

3. Use the *Geotag images* option to override, for this image only, the [Media file](#) configuration for geotagging images.
4. Tap *Accept* to link the image.
5. The image is now linked according to the setting in the [Link to](#) option.

Media file configuration

To configure how a media file is linked to the job or point in a job, do the following:

1. From the main menu, select *Jobs / Properties of job*.
2. Tap the *Media file* button.
3. From the *Link to* option, select how the images will be linked. Choose from:
 - *Job* - linked to the job
 - *Previous point* - linked to the latest point stored
 - *Next point* - linked to the next point to be stored
 - *Point name* - linked to the point entered in the *Point name* field
 - *None* - the image is saved but is not linked to the job or a point

Note – For all options, the media file is always saved to the **<jobname> Files** folder. If there is no job open, the media file is saved to the current project folder.

4. Select the *Show with new media file* option to show the media file screen immediately after capturing an image. This enables the *Link to* method to be changed and, if linking by point name, the point name.

Note – The *Show with new media file* setting controls whether the media file screen is shown for all jobs.

5. If the *Link to* option was set to *Previous point*, *Next point*, or *Point name*, you can select *Geotag images*. See [Geotagging](#) for further details.
6. Tap *Accept*.

Copying between jobs

You can copy the following items from one job to another job on the controller:

- Calibration
- All control points
- Calibration and control
- Local transformations
- Points
- RTX-RTK offset

To do this:

1. Select *Jobs / Copy between jobs*.
2. Select each of these items:
 - a job name in the *Job to copy from* field.
 - a job name in the *Job to copy to* field.
 - the items to be copied in the *Copy* field.

If you select the *Copy duplicate points* check box, the option to *Overwrite* appears.

3. If you want to copy duplicate points, and overwrite and delete the duplicate points in the job you are copying to, select the appropriate check boxes.
4. When the *Copy* field is set to Points, various point selection options become available in the *Select Point* menu. Select the appropriate option.

When copying points between jobs, make sure that the points you are copying use the same coordinate system as the job that the files are being brought into.

When copying Local transformations between jobs, all transformations are copied, and the copied transformations are not editable. To modify or update a copied transformation, update the original transformation and then copy it again.

Note - You can only copy information between jobs that are in the current [project folder](#). If the file(s) you want to copy data between are not available, use *Job open to change the current project folder*, or use *Explorer* to copy the file(s) to the current project folder.

To create a new job with **all** the defaults (including Coordinate System settings) from another job, see [Managing jobs](#)

Importing and exporting fixed and custom format files

This menu lets you send and receive data to and from another device, export and import fixed format files, export and import custom format files and transfer files between controllers.

For more information, see:

[Sending and receiving ASCII data between external devices](#)

[Import and export fixed format files](#)

[Export custom format files](#)

[Import custom format files](#)

Sending and receiving ASCII data between external devices

This section describes how to use the [Send data to another device](#) and [Receive data from another device](#) functions in the General Survey software. Use these functions to transfer point names, point codes, and grid coordinates in ASCII format between the Trimble controllers and a variety of conventional instruments, data collectors, and office computers.

In addition, you can transfer ASCII files directly to the office computer using third-party download software, such as HyperTerminal.

Note - Only points with grid coordinates are transferred when you use the ASCII data transfer function. If the job does not have a projection and datum transformation specified, GNSS points cannot be transferred. Furthermore, deleted points, and any points stored as polar vectors from a deleted point, cannot be transferred.

See:

[Transferring ASCII data to and from an external device](#)

[Sending data to another device](#)

[Receiving data from another device](#)

Transferring ASCII data to and from an external device

You can transfer ASCII data to and from an external device or office computer in the following formats:

- Trimble GDM (Area)
- Comma delimited (*.csv, *.txt)
- SDR33 coordinates
- SDR33 DC
- TDS CR5
- Topcon (FC-5)
- Topcon (GTS-7)
- Trimble DC v10.7
- Trimble DC v10.0
- SC Exchange
- Trimble Zeiss M5

Sending data to another device

WARNING - When sending data to a device that does not include a units setting as part of its file, make sure that the General Survey file uses the units setting of that device.

If you are not sure whether the device file includes a units setting, set the General Survey file to the same units as the device.

To send ASCII data to an external device:

1. Select *Jobs / Import/Export / Send data*.
2. Use the *File format* field to specify the type of file to send.
3. Set the transfer parameters:
 - a. Set the *Controller port* field to the Trimble controller port you are using for the transfer.
Note - Set the controller port to Bluetooth to send Comma Delimited, Trimble DC v10.0, Trimble DC v10.70 and SC Exchange formats to another controller using Bluetooth. Before sending files using Bluetooth, you must configure the Bluetooth connection. For more information, see [Bluetooth](#).
 - b. Set the *Baud rate* and *Parity* fields to match the corresponding parameters on the device that you are communicating with.
 - c. If the *File format* field is set to Comma Delimited (*.CSV, *.TXT), set the baud rate correctly on the external device. If appropriate, also set the flow control (xon/xoff).
 - d. If you are transferring a SDR33 .dc file, and you want the General Survey software to include a checksum when the file is transferred, select *On* in the *Checksum* field.

Notes

- For the Trimble GDM (Area), SDR33, TDS CR5, Topcon (GTS-7), Topcon (FC-5), and Trimble Zeiss M5 output options, you must select the appropriate format on the external device.
 - The Trimble Zeiss M5 output option uses the default Markings for the Trimble 3300 instrument in the coordinate file that is transferred. Markings refers to the layout of the 27 character field used for the point number and code details in the M5 format file. The Markings in the transferred file are as follows:
 - Characters 1 - 11 are unused and are output as spaces.
 - Characters 12 - 15 hold numeric point codes (right justified within these characters). Any non-numeric characters in point codes are not output to the file.
 - Characters 16 - 27 hold numeric point names assigned by the General Survey on export (right justified within these characters).
 - Make sure that the Markings settings on a 3300 instrument, and the PI1 Markings on a 3600 instrument, are configured as above when transferring ASCII files to and from General Survey.
4. Set the file parameters:
- a. If the *File format* field is set to *SDR33 coordinates* or *TDS CR5*, the *Job name* field appears. Enter a name for the file that is created when the data is transferred.
 - b. Set the *Point name* field to *Unchanged* or *Auto-generate*. *Unchanged* sends the point names as they appear on the Trimble controller. *Auto-generate* adds two extra fields:
 - Use the *Start point name* field to specify the name of the first point to be transferred.
 - Use the *Auto point step size* field to define the amount by which the *Start point* value is incremented or decremented when the General Survey software generates point names for subsequently transferred points.

Note - If the *File format* field is set to *TDS CR5* and the *Point name* field is set to *Unchanged*, a point will only be transferred if the point name is less than eight characters long and contains numeric characters only.
 - c. Use the *Point code* field to specify what is sent to the external device selected in the *Code* field:
 - Select *Use point code* to send the point code.
 - Select *Use point name* to send the point name.

Note - If you have used long codes in the General Survey software, and the file format you are transferring to does not support long codes, the codes will be shortened.
 - d. If the *File format* field is set to *SDR33 coordinates*, there is an *Output notes* check box. Select this to output all user-entered notes with the point data. The notes are output in SDR33 record 13NM format.
 - e. If the *Comma Delimited (*.CSV, *.TXT)* option is selected, you can specify the format of the data that is received. Five fields appear: *Point name*, *Point code*, *Nothing*, *Easting*, and *Elevation*.
- Using the options provided, select a position for each field. Select *Unused* if a particular value is not present in the file being received. For example:

Point name Field 1

Point code Unused

Northing Field 2

Easting Field 3

Elevation Field 4

5. Transfer the files:
 - a. When the format details are complete, tap *Send*.
 - b. If you are sending points (not a .dc file), the *Select points* screen appears. Tap *Add* to select the [point selection method](#) and then select the points to send.
 - c. The General Survey software prompts you to initiate receiving on the instrument that you are sending data to. For more information about receiving data, refer to the manual for the receiving device.
 - d. When the other device is ready to receive, tap *Yes* to send the data. The data is transferred.

Notes

- *When sending ASCII data from a Trimble controller to an external device, it is important to follow on-screen instructions. The cable must not be connected until you are prompted to do so. If you connect the cables at the wrong time, the transfer will fail.*
- *In an SC Exchange .dc file, all observations are reduced to WGS84 positions and grid positions (coordinates). Use this file format to transfer .dc files between different versions of the General Survey software.*
- *General Survey outputs the latest version SC Exchange DC file that the software knows about. When importing SC Exchange files, General Survey reads all records it knows about. If importing a new version SC Exchange file into an older version of General Survey, the software does not read new records that it does not understand.*
- *The Trimble GDM (Area) and Trimble Zeiss M5 formats created using the General Survey Send data option are designed for data transfer to terrestrial instruments. The file format used is different from the GDM job and M5 files downloaded using Data Transfer.*

Receiving data from another device

WARNING - When receiving data from a device that does not include a units setting as part of its file, make sure that the General Survey file uses the units setting of that device. If you are not sure whether the device file includes a units setting, set the General Survey file to the same units as the device.

To receive ASCII data from an external device:

1. Select *Jobs / Import / Export / Receive data*.
2. Use the *File format* field to specify the type of file to receive.
3. Set the transfer parameters:
 - a. In the *Port details / Controller port* field, select the Trimble Controller port used for the transfer.

Note - Set the controller port to Bluetooth to receive Comma Delimited, Trimble DC v10.0, Trimble DC v10.70 and SC Exchange formats to another controller using Bluetooth. Before receiving files using Bluetooth, you must configure the Bluetooth connection. For more information, see [Bluetooth](#).

- b. Set the *Baud rate* and *Parity* fields to match the corresponding parameters on the device that the General Survey software is communicating with.

Note - If the *File format* field is set to Comma Delimited (*.CSV, *.TXT), set the baud rate correctly on the external device. If appropriate, also set the flow control (xon/xoff).

If you are transferring a SDR33 .dc file, and you want the General Survey software to validate the checksum when the file is transferred, select *On* in the *Checksum* field.

4. The option in the *File format* field determines what you do next:
- If you select one of the following options, you must choose the appropriate output format on the external device:
 - Comma delimited (*.csv, *.txt)
 - SDR33 coordinates
 - SDR33 DC
 - TDS CR5
 - Topcon (FC-5)
 - Topcon (GTS-7)
 - Trimble DC v10.7
 - Trimble DC v10.0
 - SC Exchange
 - Trimble Zeiss M5

Use the *Point name* field to define how the point names in the data are received.

Notes

- In the case of the Trimble Zeiss M5 format the *Markings* (organization of the 27 character point number and code field) must conform to the following definitions:
 - Characters 12 - 15 holding the point code
 - Characters 16 - 27 holding the point name
- General Survey point names have a maximum of 16 characters, but some points received from other devices can exceed this. If point names have 16 characters or more, choose either *Truncate left* or *Truncate right*.
- If the Comma Delimited (*.CSV, *.TXT) option is selected, you can specify the format of the data that is received. Five fields appear: *Point name*, *Point code*, *Northing*, *Easting*, and *Elevation*.

Using the options provided, select a position for each field. Select *Unused* if a particular value is not present in the file being received. For example:

Point name Field 1

Point code Unused

Northing Field 2

Easting Field 3

Elevation Field 4

To store the files:

1. When the format details are complete and the external device is ready to send, connect the cables and tap *Receive*.

The General Survey software prompts you to initiate sending on the external device. For more information about sending data, refer to the manual for the sending device.

When sending is initiated, the General Survey software starts to receive data, and a progress bar appears.

When the transfer is complete, the General Survey software automatically terminates the operation and saves the received data.

2. If it is clear that the transfer is complete but the operation has not been terminated, tap *Esc*. The following message appears:

Transmission interrupted. What would you like to do now? Do one of the following:

- Tap *Continue* to return the General Survey software to receive mode.
- Tap *Finish* to terminate the operation and save any received data to the current job.
- Tap *Cancel* to terminate the operation and discard any received data.

Note - When receiving ASCII data from an external device to a Trimble controller, you must follow the on-screen instructions. Do not connect the cable until you are prompted to do so, otherwise the transfer will fail.

Import and export fixed format files

Use these functions to:

- Import a fixed format file and convert it to a new Trimble job file
- Export a fixed format file from a Trimble job file and create a new file

The following formats are available:

- Comma delimited (*.csv, *.txt)
- SDR33 DC
- Trimble DC v10.7
- Trimble DC v10.0
- SC Exchange
- Trimble JobXML
- [ESRI Shapefiles](#)
- [DXF](#)

When you create files using *Export fixed format* or *Export custom format*, you can save the new format files to an existing folder on the controller, or create a new one. The default folder is the Export folder inside the current [project folder](#). If you change the project folder, the system creates an export folder under the new project folder, and gives it the same name as the previous export folder.

Tap  to select an existing folder or create a new one.

If the Trimble JobXML option is selected, select the appropriate version number.

If the Comma Delimited (*.CSV, *.TXT) option is selected, you can specify the format of the data that is received. Five fields appear: *Point name*, *Point code*, *Northing*, *Easting*, and *Elevation*.

Using the options provided, select a position for each field. Select *Unused* if a particular value is not present in the file being received. For example:

Point name Field 1

Point code Unused

Northing Field 2

Easting Field 3

Elevation Field 4

To select points to export, see [Selecting points](#).

If [description fields](#) are enabled for the job, there are two additional fields to configure.

When the [Advanced Geodetic](#) option is enabled, you must set the [Coordinate view](#) to Grid or Grid (local). Set it to Grid when importing regular grid coordinates. When Grid (local) is selected, you can import a CSV file containing Grid (local) coordinates. You can assign the *Transformation* to grid coordinates when you import the points, or later using [Point manager](#).

You can create a transformation when you import grid local points, but you cannot use the grid local points from the file you are about to import unless that file has already been linked to the current job.

Null elevations

If the comma-delimited file you are importing contains 'null elevations' that are defined as something other than null, for example a 'dummy' elevation such as -99999, you can configure the format of the *Null elevation* and the General Survey software converts these 'null elevations' to real null elevations inside the General Survey job file.

The *Null elevation* value in *Import fixed format files* is also used when points are imported or copied from linked CSV files.

Tip - Dummy 'null elevations' can also be converted to true null elevations using the 'NullValue' string in Custom ASCII Import.

Notes

- *Importing from a JobXML file to a Trimble job file is mainly used to transfer the coordinate system definition and design information. A JobXML file generated from a Trimble job contains all the raw data in the FieldBook section, and "the best" coordinate for each point from the job in the Reductions section. Only the data from the Reductions section is read into the new Trimble job file, raw observations are not imported.*
- *The General Survey software remembers where to export files only up to two folders below the project folder. If you send export files to subfolders deeper than that, you must set the folder each time you export a file.*
- *Use custom ASCII export to export Grid (local) coordinates. You cannot use Export fixed format files to export Grid (local) coordinates.*

To learn more about customizing your own ASCII format, see [Export custom format files](#).

Duplicate point storage options when importing points

When importing a comma delimited file, use the *Duplicate point action* field to control how points of the same name as existing points in the job are imported. Select:

- *Overwrite* to store the imported points and delete all existing points of the same name.
- *Ignore* to ignore the imported points of the same name so that they are not imported.
- *Store another* to store the imported points and keep all existing points of the same name.

Exporting ESRI shapefiles

To create and transfer ESRI shapefiles from a Trimble controller to an office computer, using the Data Transfer utility, see Transferring ESRI shapefiles.

Note - You cannot use this option to transfer shapefiles that were created on the controller. To do that, you must use use Windows Mobile Device Center.

To create ESRI shapefiles on the controller:

1. Select *Jobs / Import / Export / Export fixed format*.
2. Set the *File format* type to *ESRI shapefiles*.
3. Tap  to select an existing folder or create a new one.
4. Set the file name, set the *Coordinates* to either *Grid* (northing/easting/elevation) or *Lat/Long coordinates* (local latitude/longitude/height), and then tap *Accept*.

Exporting DXF files

To create DXF files on the controller:

1. Select *Jobs / Import / Export / Export fixed format*.
2. Set the *File format* type to *DXF*.
3. Tap  to select an existing folder or create a new one.
4. Set the file name and then select the DXF file format.
5. Select the entity types to export and then tap *Accept*.

Supported entity types:

- Points
- Feature coded linework
- Database linework

The DXF file is transferred to the folder specified.

Notes

- *If a point has features and attributes assigned to it then all the attributes are added as attributes of the inserted point in the DXF file.*
- *Layers and Line color*
 - *When a feature code library (*.fxl) created by the Trimble Business Center software's Feature Definition Manager is used, the fxl defined layers and colors are used in the DXF.*

- *Where an exact color cannot be matched it finds the next closest match.*
- *When a feature code library is created on the controller it uses the line color specified in the Trimble Access software.*
- *If a layer has not been defined, feature coded lines are assigned to the Lines layer and points are assigned to the Points layer. Database lines always go to the Lines layer.*
- *Only Solid and Dashed line types are currently supported.*

Export custom format files

Use this menu to create custom ASCII files on the controller while in the field. Use the predefined formats or create your own custom formats. With custom formats, you can create files of almost any description. Use these files to check data in the field, or to produce reports, which you can transfer from the field to your client or to the office for further processing with the office software.

The predefined ASCII export formats available on the controller include:

- Check shot report
- CSV with attributes
- CSV WGS-84 lat longs
- GDM area
- GDM job
- ISO Rounds report
- M5 coordinates
- Road-line-arc stakeout report
- Stakeout report
- Survey report
- Traverse adjustment report
- Traverse deltas report

These custom export ASCII formats are defined by the XSLT style sheet (*.xsl) definition files. They can be located in both the language folder and in [System files] folder. Translated custom export stylesheet files are typically stored in the appropriate language folder.

You can modify a predefined format to meet your specific requirements, or use it as a template to create a completely new custom ASCII export format.

In addition, go to www.trimble.com/Survey/Trimble-Access-IS.aspx to download the following predefined formats:

- CMM coordinates
- CMM elevations
- KOF
- SDMS

Creating a report of survey data

1. Open the job that contains the data to export.
2. From the main menu, select *Jobs / Import/Export / Export custom format*.
3. In the *File format* field, specify the type of file to create.
4. Tap  to select an existing folder or create a new one.
5. Enter a filename.

By default, the *File name* field shows the name of the current job. The filename extension is defined in the XSLT style sheet. Change the file name and extension as required.

6. If more fields are displayed, complete them.

You can use the XSLT style sheets to generate files and reports based on parameters that you define.

For example, when generating a Stakeout report, the *Stakeout horizontal tolerance* and the *Stakeout vertical tolerance* fields define acceptable stakeout tolerances. When generating the report you can stipulate the tolerances, then any stakeout delta greater than the defined tolerances appears in color in the generated report.

7. To automatically view the file after you create it, select the *View created file* check box.
8. To create the file, tap *Accept*.

Note - When the selected XSLT style sheet is applied to create the custom export file, the processing is all carried out in the program memory available on the device. If there is not enough memory to enable the creation of the export file, an error message will be displayed and no export file will be created.

Four factors will affect whether the export file can be created

- The amount of program memory available to the device.
- The size of the job being exported.
- The complexity of the style sheet being used to create the export file.
- The amount of data being written to the export file.

If it is not possible to create the export file on the controller, download the job as a JobXML file to a computer.

To create the export file from the downloaded JobXML file using the same XSLT style sheet, use the ASCII File Generator utility program. To download this utility, go to www.trimble.com/Survey/Trimble-Access-IS.aspx.

Creating XSLT stylesheets to define custom ASCII formats

You can use any text editor, such as Microsoft Notepad, to make minor changes to the predefined formats. However, to create a completely new custom ASCII format, you need some basic programming knowledge.

You cannot easily modify or create a style sheet on the controller. To successfully develop new style sheet definitions, work on an office computer using a suitable XML file utility program.

The predefined formats on the controller can also be downloaded from

www.trimble.com/Survey/Trimble-Access-IS.aspx. You can edit them and then transfer them to the

controller using Windows Mobile Device Center. To retain the existing formats, save the modified formats with a new XSLT filename.

To develop your own XSLT style sheets, you need:

- An office computer.
- Basic programming skills.
- An XML file utility program with good debugging facilities.
- The JobXML file schema definition that provides the details of the JobXML format required to create a new XSLT style sheet.
- A General Survey Job or JobXML file that contains the source data.

The predefined XSLT style sheets, JobXML file schema and the ASCII File Generator utility can be downloaded from www.trimble.com/Survey/Trimble-Access-IS.aspx. For information on using this utility, refer to the ASCII File Generator Help.

The basic steps are:

1. Source a Job file or JobXML file from your Trimble controller. Use one of the following methods:
 - Transfer a Job file from the controller using Windows Mobile Device Center or Data Transfer and then use the job file directly with the ASCII File Generator.
 - Transfer a Job file from the controller using Windows Mobile Device Center or Data Transfer and then use the ASCII File Generator to create a JobXML file.
 - Create a JobXML file on the controller. From the *Import/Export / Create ASCII file* menu, set the *File format* field to *Trimble JobXML*. Transfer the JobXML file using Windows Mobile Device Center.
 - Create and transfer a JobXML file using Data Transfer. Make sure that the *Files of type* field is set to *JobXML Files*.
2. Create the new format using a predefined XSLT style sheet as a starting point and the JobXML schema as a guide.
3. To create the new custom ASCII file on the office computer, use the ASCII File Generator utility to apply the XSLT style sheet to the Trimble Job or JobXML file.
4. To create the custom ASCII files on the controller, copy the file to the [System files] folder on the controller.

Notes

- *XSLT style sheet definition files are XML format files.*
- *The predefined style sheet definitions are provided in English. Modify these files as required to your own language.*
- *During installation, new versions of the predefined ASCII import and export formats are installed to the controller. If you have created new custom import or export formats or modified and **renamed** the existing formats then these files are now reinstalled to the controller during the Transfer Downloaded Trimble Files step of the upgrade process. If you modified the predefined formats and saved them with the same name, they will be replaced when you upgrade the controller. The downloaded files still exist on your office computer. If you create new formats, or customize the predefined formats, Trimble recommends you save*

the files with a new name. Use the Trimble Data Transfer utility or Windows Mobile Device Center to transfer these files back onto the controller once the upgrade is complete.

- Style sheets must be created according to the XSLT standards as defined by the World Wide Web Consortium (W3C). For details, go to www.w3.org.
- The Trimble JobXML file schema definition provides details of the JobXML file format.

Creating a custom ASCII export file with Grid (local) coordinates

Export custom format is the only way to export points with Grid (local) coordinates.

Use the *Grid (local) coordinates* XSLT style sheet available on the controller to create a custom ASCII export comma-delimited file with Grid (local) and Grid coordinates. Or modify that style sheet to create your own custom format.

There are two types of Grid (local) coordinates that can be output; the original entered grid (local) coordinates, or the computed display grid (local) coordinates. When creating the export file, the software prompts you for the required output.

The computed grid (local) coordinates are derived by taking the keyed-in or computed grid coordinates and then applying the display transformation. You must set the display transformation required in General Survey before you export the ASCII file. To do this in *Review job*, select a point, go to *Options*, set the *Coordinate view* to Grid (local) and then select a *Transformation for grid (local) display*. Alternatively, set the display transformation using *Point manager*.

Import custom format files

Use this menu to import custom ASCII files into your current job. You can use the predefined formats or create your own custom format to import fixed-width or delimited ASCII files.

You can import the following data using this option:

- Point name
- Code
- Description 1 and Description 2
- Notes attached to points
- Grid coordinates
- WGS84 geographic coordinates (degrees minutes and seconds, or decimal degrees)
To be successfully imported, points must have a height.
- Local geographic coordinates (degrees minutes and seconds, or decimal degrees)
To be successfully imported, points must have a height
- Line definitions

Before you import, line start and end points must exist in the database.

Line definitions include the following information: start point name, end point name, start station, station interval, azimuth, and length.

The predefined ASCII import formats available in the controller include:

- CSV Grid points E-N
Point Name, Easting, Northing, Elevation, Code
- CSV Grid points N-E
Point Name, Northing, Easting, Elevation, Code
- CSV Lines
Start Point Name, End Point Name, Start Station, Station Interval
- CSV WGS-84 Lat-long points
Point Name, Latitude, Longitude Height, Code

These custom import ASCII formats are defined by .ixl import definition files that are stored in the [System files] folder.

Importing an ASCII file using a predefined file format

1. Transfer the file to be imported into the [project folder](#) on the controller.
2. Open or create the job that you want to import the data into.
3. From the main menu, select *Jobs / Import/Export / Import custom format*. (If you are using the Mines application, select *Jobs / Import custom format*.)
4. In the *File format* field, specify the type of file to import.
5. Tap  to select an existing folder or create a new one.
6. In the *File name* field, select the file to import. All files in your data folder with the file extension specified in the format file (by default CSV) appear in the list.
7. If you are importing points, select or clear, as required, the *Import points as control* check box to specify if the imported points should be control points.
8. To import the file, tap *Accept*. After import, a summary box shows how many items were imported and how many were discarded.

Creating custom ASCII import format files

Custom ASCII import format files are stored on the controller in the [System files] folder, with the extension *.ixl. You can make simple edits to existing format files on the controller using Microsoft Pocket Word software. If you have majors edits or you want to create new format files, use a text editor on a desktop computer.

For information on how to create your own import formats, refer to the Import Custom Format Files document available at www.trimble.com/Survey/Trimble-Access-IS.aspx.

Key In

Key in menu

This menu lets you enter data into the General Survey software from the keypad.

You can key in:

- Points
- Lines
- Arcs
- Alignments (polylines)
- Notes

Keying in points

With this function, you can enter coordinates to define a new point:

1. From the main menu, select *Key in / Points*.
2. Enter the point name.
3. Enter the values. Depending on the coordinate view and the controller, you may need to view the computed grid coordinates from the second page.
4. Tap *Store* to store the point.

You can also key in a point from [the map](#).

To configure the *Coordinate view*, tap *Options*.

Station and offset

When you key in a point by a *Station and offset* value, select from the *Type* field the entity the *station and offset* values are relative to.

Grid (local)

When you key in a point by Grid (local), from the *Transformation* field, select:

- an existing transformation
- create a *New transformation*

- *None* to define the transformation later

From the map

1. Make sure the current selection is cleared.
2. Tap and hold on the area of the map to which you want to add the point.
3. From the shortcut menu, select *Key in point*.
4. Complete the fields as required.

Keying in lines

Use this function to define a new line by one of the following methods:

[Two points](#)

[Brng-dist from a point](#)

Defining a new line by using two points

1. Do one of the following:
 - From the map, select the *Start point (1)* and the *End point (2)*. (See the diagram below.) Tap and hold on the map and select *Key in line* from the shortcut menu.
 - Select *Key in / Line* from the main menu. In the *Method* field, select *Two points*. Enter the names of the *Start point* and the *End point*.
2. Use *Options* to specify ground, grid, or sea level distances.
3. Enter the name of the line.
4. Enter values for the *Start station* and the *Station interval*.

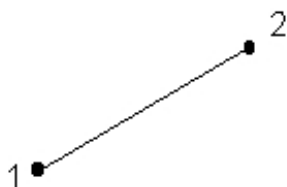

Defining a new line using a brng-dist from a point

1. From the main menu, select *Key in / Line*.
2. Use *Options* to specify ground, grid or sea level distances.
3. Enter the name of the line.
4. In the *Method* field, select *Brng-dist from a point*.

4 Key In

5. Enter the name of the Start point (1), the azimuth (2), and the length of line (3). See the diagram below.
6. Specify the *Grade* between the start and end points.
7. Enter values for the *Start station* and the *Station interval*.

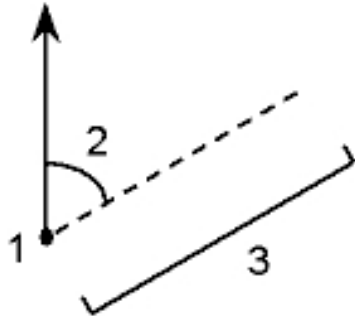

Keying in arcs

Use this function to define a new arc by one of the following methods:

- Two points and radius
- Arc length and radius
- Delta angle and radius
- Intersect point and tangents
- Two points and center point
- Three points

The following diagram and table explains the terms used to define features of an arc.

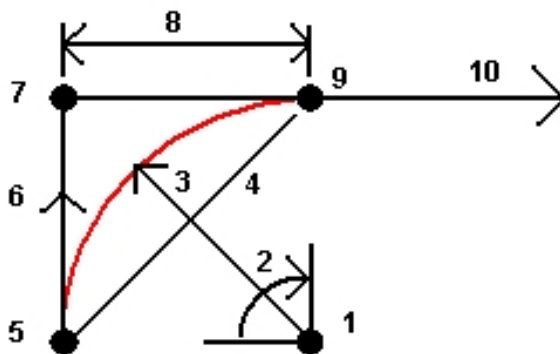

1	Center point	6	Back tangent
2	Delta angle	7	Intersection point
3	Radius	8	Tangent length

4	Chord length	9	To point
5	From point	10	Forward tangent

The back tangent value (6) is related to the direction (right in the above diagram) in which the station or chainage increases. For example, when you stand at the intersection point (7) looking in the direction of increasing station or chainage, the forward tangent (10) is in front of you and the back tangent (6) is behind you.

The direction field defines whether the arc turns to the left (counterclockwise) or right (clockwise) from the start point (1) to the end point (2). The following diagram shows both a left (3) and right (4) arc.

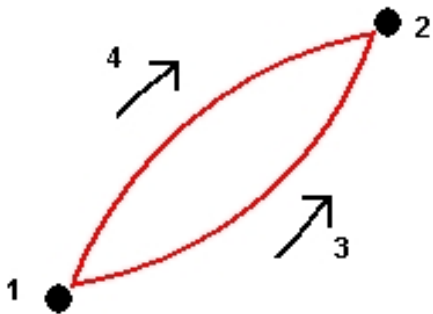

Defining an arc using two points and a radius

1. From the main menu, select *Key in / Arcs*.
2. Use *Options* to specify ground, grid, or sea level distances.
3. Enter the name of the arc.
4. In the *Method* field, select *Two points and radius*.
5. As shown in the diagram below, enter the name of the start point (1), the name of the end point (2), and the radius (3) of the arc.

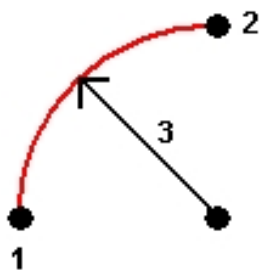

6. Specify the direction of the arc.
7. Enter values for the *Start station* and the *Station interval*.
8. If required, select the *Store center point* check box and then enter a point name for the centre point.

Defining an arc using the arc length and radius

1. From the main menu, select *Key in / Arc*.
2. Use *Options* softkey to specify ground, grid, or sea level distances and the grade entry method.
3. Enter the name of the arc.
4. In the *Method* field, select *Arc length and radius*.
5. As shown in the diagram below, enter the name of the start point (1), the back tangent (2), the radius (3) and the length of the arc.

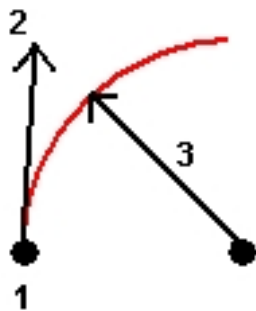

6. Specify the direction of the arc and the grade between the start and end points.
7. Enter values for the *Start station* and the *Station interval*.
8. If required, select the *Store center point* check box and then enter a point name for the centre point.

Defining an arc using the delta angle and radius

1. From the main menu, select *Key in / Arc*.
2. Use *Options* to specify ground, grid, or sea level distances and the grade entry method.
3. Enter the name of the arc.
4. In the *Method* field, select *Delta angle and radius*.
5. As shown in the diagram below, enter the name of the start point (1), the back tangent (2), the radius (3) and the turned angle (4) of the arc.

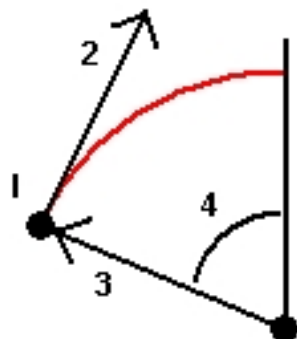

6. Specify the direction of the arc and the grade between the start and end points.
7. Enter values for the *Start station* and the *Station interval*.
8. If required, select the *Store center point* check box and then enter a point name for the centre point.

Defining an arc using the intersect point and tangents

1. From the main menu, select *Key in / Arc*.
2. Use *Options* to specify ground, grid or sea level distances.
3. Enter the name of the arc.
4. In the *Method* field, select *Intersect point and tangents*.
5. As shown in the diagram below, enter the name of the intersection point (1), the back tangent (2), the forward tangent (3) and the radius (4) of the arc.

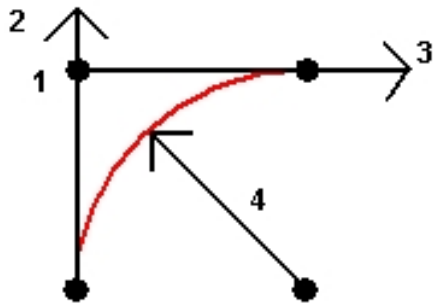

6. Enter values for the *Start station* and the *Station interval*.
7. If required, select the *Store center point* check box and then enter a point name for the centre point.

Defining an arc using two points and a center point

1. From the main menu, select *Key in / Arc*.
2. Use *Options* to specify ground, grid or sea level distances.
3. Enter the name of the arc.
4. In the *Method* field, select *Two points and center point*.
5. Specify the direction of the arc.
6. As shown in the diagram below, enter the name of the *Start point* (1), the *End point* (2), and the *Center point* (3) of the arc.

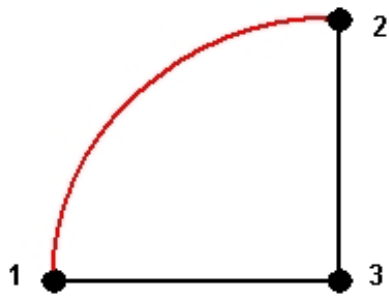

7. Enter values for the *Start station* and the *Station interval*.

Defining an arc using three points

1. From the main menu, select *Key in / Arc*.
2. Use *Options* to specify ground, grid or sea level distances.
3. Enter the name of the arc.
4. In the *Method* field, select *Three points*.
5. As shown in the diagram below, enter the name of the *Start point* (1), the *Point on arc* (2), and the *End point* (3) of the arc.

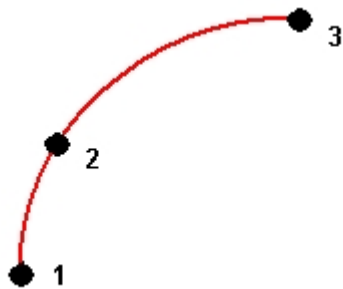

6. Enter values for the *Start station* and the *Station interval*.
7. If required, select the *Store center point* check box and then enter a point name for the centre point.

The grade of the arc is determined by the elevations of the arc start and end points.

Keying in alignments

1. From the main menu, select *Key in / Alignments*.
2. To key in a new alignment, enter the point names that define the alignment (if the *Key in alignment* screen is displayed). If the *Select an alignment* screen is displayed, tap *New* to enter the point range.

The following name range techniques are supported:

Enter	Result
1,3,5	Creates a line between points 1 to 3 to 5
1-10	Creates lines between all points from 1 through 10
1,3,5-10	Creates a line between points 1 to 3, to 5, and 5 through 10
1(2)3	Creates an arc between points 1 and 3, through point 2
1(2,L)3	2 (Radius point), L (left) or R (right) Creates a Left hand arc between points 1 and 3, with point 2 as the radius point
1(100,L,S)3	1 to 3, radius=100, L (left) or R (right), L (large) or S (small) Creates a Left hand Small arc between points 1 and 3 with a radius of 100

- To store the alignment, select the *Store alignment* check box, enter an *Alignment name*, enter a *String name* (if required) and a *Start station* and *Station interval* and then tap *Store*.

Alignments are stored as RXL files. If you save the alignment, you can easily stake it again, view it in the map, and share it with other jobs and with other controllers.

Alignments always have a horizontal component; the vertical component is optional. If an alignment is created using entities that have elevations, the alignment will have a vertical component.

- To offset an alignment, tap *Offset*.
- Enter the offset distance. To offset to the left, enter a negative value.
- To store the offset alignment, enable the *Store alignment* check box, enter an *Alignment name*, enter a *String name*, if required, and then tap *Store*. The alignment is stored as an RXL file.
- To store node points at the vertices of the offset alignment, enable the *Store points at nodes* check box, enter a *Start point name*, enter a *Code*, if required, and then tap *Store*.

An offset alignment will have a vertical component if the vertical geometry of the original alignment is coincident with the horizontal geometry and the vertical geometry consists only of points. The offset vertical geometry cannot include curves. If the vertical geometry of an alignment cannot be offset, only the horizontal component will exist in the offset alignment. You cannot offset an alignment that includes transitions.

Tip - You can also define the horizontal component (and vertical component if the line work has elevations), from features (points, lines, and arcs), in a file. To do this:



- From the map, go to the *Layers* screen, select the file and then make active the appropriate layer(s) that will be used to define the horizontal component.
- Select the feature. See [Using the map for common tasks](#) for further details.
- From the tap and hold menu, select *Key in alignment*.
- Select *Store alignment* and then enter a name, start station, and station interval.
- Tap *Store*.

For more information, see:

- [Staking out alignments](#) (polylines)

Keying in notes

You can enter a note in the General Survey database at any time. To do this:

1. To access the *Key in note* screen, do one of the following:
 - From the main menu, select *Key in / Notes*.
 - Tap *Favorites / Key in note*.
 - On the controller keyboard, press **CTRL + N**.
2. Type in the details to be recorded. Alternatively tap *T/Stamp* to generate a record of the current time.
3. To store the note do one of the following:
 - Tap *Store* to store the note in the database.
 - Tap  *Prev* to attach the note to the previous observation.
 - Tap  *Next* to attach the note to the next observation to be stored.

Note - When you use  *Next*, the note is only stored with the next observation if another observation is stored during the current survey. If the survey is ended without storing another observation the note is discarded.

4. To exit *Key in notes*, tap *Esc*. Alternatively, if the *Note* form is empty, tap *Store*.

Note - If a feature code list is already selected for the job, you can use codes from the list when keying in a note. From the *Note* screen, press *Space* to display the feature code list. Select a code from the list or type the first few letters of the code.

In *Review*, tap *Note* to add a note to the current record.

In *Point manager*, scroll to the right and tap in the *Note* field to add a note to the point record.

Cogo

Cogo menu

This menu lets you carry out Coordinate Geometry (Cogo) functions. You can use the menu options to calculate distances, azimuths, and point positions by various methods.

For some calculations, you must define a projection, or select a Scale factor-only coordinate system.

You can display ellipsoid, grid, or ground distances by changing the *Distances* field in the [Cogo settings](#) screen.

To perform Cogo calculations in a *No projection / No datum* coordinate system, set the *Distances* field to *Grid*. The General Survey software then performs standard Cartesian computations. If the grid distances you enter are distances on the ground, the new computed grid coordinates will be ground coordinates.

Note - When the *Distances* field is set to *Ground* or *Ellipsoid*, the General Survey software attempts to perform calculations on the ellipsoid. Because there is no relationship established at this point, the system cannot compute coordinates.

You can compute a distance between two points directly in a distance field. To do this, enter the point names in the distance field, separated by a hyphen. For example, to compute the distance between points 2 and 3, enter "2-3". This method works with most alphanumeric point names, but it does not support point names that already contain a hyphen.

You can compute an azimuth from two points directly in an azimuth field. To do this, enter the point names in the *Azimuth* field, separated by a hyphen. For example, to compute the azimuth from point 2 to point 3, enter "2-3". This method works with most alphanumeric point names, but it does not support point names that already contain a hyphen.

For more information, see:

- [Compute inverse](#)

- [Compute point](#)

- [Compute volume](#)

- [Compute distance](#)

- [Compute azimuth](#)

- [Compute average](#)

- [Area calculations](#)

- [Arc solutions](#)

Triangle solutions

Subdivide a line

Subdivide an arc

Transformations

Traverse

Taped distances

Calculator

Compute inverse

To compute the inverse between two existing points:

1. From the map, select the From point (1) and To point (2), as shown in the diagram below.
2. Tap and hold on the map and select *Compute inverse* from the shortcut menu. Alternatively, select *Cogo / Compute inverse* from the main menu.
3. The following values are computed:
 - azimuth (3)
 - horizontal distance (4)
 - the change in elevation, slope distance and grade between the two points
 - delta north (5) and east (6)

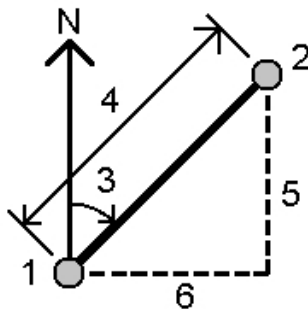

Compute point

Use this Cogo function to calculate the coordinates of an intersection point from one or more points, a line, or an arc. You can store the results in the database.

Use *Options* to specify ground, grid, or sea level distances.

To measure distances or offsets using a laser rangefinder, you must first connect the laser rangefinder to the controller and configure the laser rangefinder in your survey style. For more information, see [Configuring a survey style to use a laser rangefinder](#). If the *Auto measure* field in the survey style *Laser rangefinder* option is set to *Yes*, the General Survey software instructs the laser to take a measurement when you tap *Laser*. To insert a distance into a *Distance*, *H.Distance* or an

Offset field, tap *Laser* from the pop-up menu and measure the distance with the laser. See also [Measuring points with a laser rangefinder](#).

Warning - In general, do not compute points and then change the coordinate system or perform a calibration. If you do, these points will be inconsistent with the new coordinate system. An exception to this is points computed using the *Brng-dist from a point* method.

Calculate coordinates using one of the following methods:

[Brng-dist from a point](#)

[Turned angle and distance](#)

[Brng-dist intersect](#)

[Brng-brng intersect](#)

[Dist-dist intersect](#)

[Four point intersection](#)

[From a baseline](#)

[Project point to line](#)

[Project point to arc](#)

Notes

- When entering an existing point name you can select from the list, perform a fast fix or measure a point. Fast fix stores an automatic rapid point with a temporary point name.
- If the measured points were measured using GNSS, the coordinates of the point can only be displayed as grid values if a projection and a datum transformation are defined.
- For all methods when the point is stored use the *Store as field* to specify if the calculated point is to be stored as WGS84, Local or Grid coordinates values.
- If you use the *Four point intersection* method or the *From a baseline* method and then change the antenna height record for one of the source points, the coordinates of the point will not be updated.

Brng-dist from a point

To calculate the coordinates of an intersection using the *Brng-dist from a point* method:

1. From the main menu, select *Cogo / Compute point*.
2. Enter a *Point name*.
3. In the *Method* field, select Bearing and distance.
4. In the *Start point* field, use the advanced pop-up arrow () to select either a Radial or Sequential measurement method. When *Sequential* is selected the *Start point* field is automatically updated to the last stored intersection point (see diagrams below).
5. Set the *Azimuth origin* to either Grid 0°, True, Magnetic, or Sun (GNSS only).
6. As shown in the diagrams below, enter the name of the Start point (1), the azimuth (2) and the horizontal distance (3).

To adjust the entered azimuth value:

- In the *Azimuth* field, use the pop-up menu to adjust the azimuth by $+90^\circ$, -90° , or $+180^\circ$.
 - Enter a value in the *Delta azimuth* field. The *Computed azimuth* field displays the azimuth adjusted by the delta azimuth.
7. Tap *Calc* to calculate the intersection point (4).
 8. Store the point in the database.

Radial:

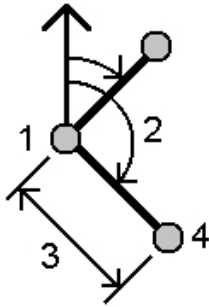

Sequential:

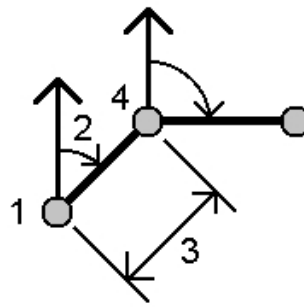

To compute the misclosure of a loop of points:

1. Give the last point the same name as the first start point.
2. Tap *Calc* for the point coordinates.

When you tap *Store*, the loop misclosure appears on the screen. Store the last point as a check to avoid overwriting the first point.

Turned angle and distance

To calculate the coordinates of an intersection using the turned angle and distance method:

1. From the main menu, select *Cogo / Compute point*.
2. Enter a *Point name*.
3. In the *Method* field, select Turned angle and distance.
4. In the *Start point* field, tap the advanced pop-up arrow (▾), then select either a *Radial* or *Sequential* measurement method. When *Sequential* is selected, the *Start point* name automatically updates to the last stored intersection point (see diagrams below).
5. In the *End point* field, tap the advanced pop-up arrow (▾), then select either an *Azimuth* or *End point* to define a reference orientation.

When using the sequential method, the reference orientation for new points moving forward is the computed reverse azimuth from the previous turned angle.

6. As shown in the diagrams below, enter the name of the *Start point* (1), the azimuth (2) and the horizontal distance (3).
7. Tap *Calc* to calculate the intersection point (4).
8. Store the point in the database.

Radial:

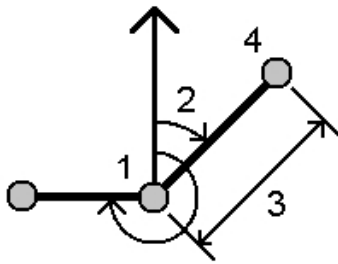

Sequential:

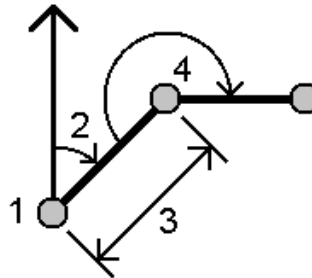

Brng-dist intersect

To calculate the coordinates of an intersection using the Brng-dist intersect method:

1. From the main menu, select *Cogo / Compute point*.
2. Enter a *Point name*.
3. In the *Method* field, select Brng-dist intersection.
4. As shown in the diagram below, enter the name of Point 1 (1), the azimuth (2), the name of Point 2 (3) and the horizontal distance (4).
5. Tap *Calc*.
6. There are two solutions (5,6) for this calculation; tap *Other* to see the second solution.
7. Store the point in the database.

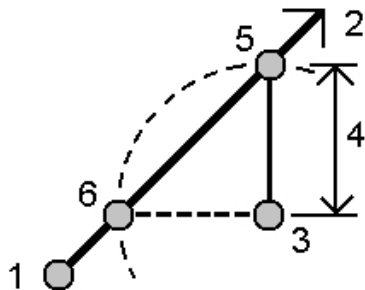

Brng-brng intersect

To calculate the coordinates of an intersection using the Brng-brng intersect method:

1. From the main menu, select *Cogo / Compute point*.
2. Enter a *Point name*.
3. In the *Method* field, select Brng-brng intersect.
4. As shown in the diagram below, enter the name of Point 1 (1), the azimuth from point one (2), the name of Point 2 (3), and the azimuth from point two (4).
5. Tap *Calc* to calculate the intersection point (5).

6. Store the point in the database

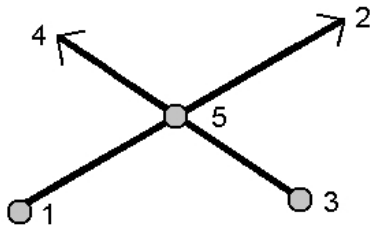

Dist-dist intersect

To calculate the coordinates of an intersection using the Dist-dist intersect method:

1. From the main menu, select *Cogo / Compute point*.
2. Enter a *Point name*.
3. In the *Method* field, select Dist-dist intersect.
4. As shown in the diagram below, enter the name of Point 1 (1), the horizontal distance (2), the name of Point 2 (3) and the horizontal distance (4).
5. Tap *Calc*.
6. There are two solutions (5,6) for this calculation; tap *Other* to see the second solution.
7. Store the point in the database.

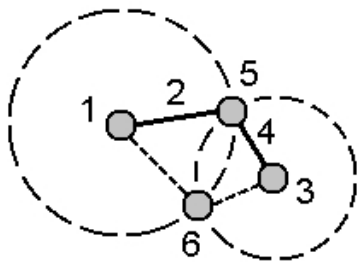

Four point intersection

To create a point using the four point intersection method:

1. From the main menu, select *Cogo / Compute point*.
2. Enter a *Point name*.
3. In the *Method* field, select Four point intersection.
4. As shown in the diagram below, enter the names of the start point of line 1 (1), the end point of line 1 (2), the start point of line 2 (3) and the end point of line 2 (4).
5. Enter any change in the vertical position as a vertical distance from the end of line 2.
6. To calculate the offset point (5), tap *Calc*.

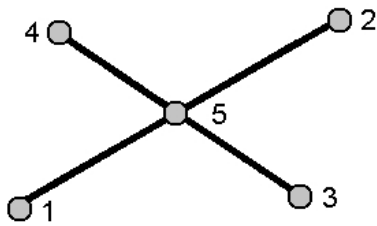

Note - The two lines do not have to intersect, but they must converge at some point, as shown below.

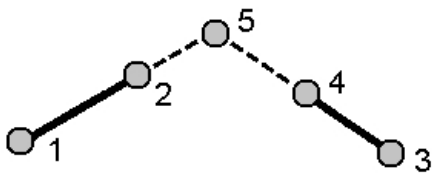

From a baseline

To create a point using the From a baseline method:

1. From the main menu, select *Cogo / Compute point*.
2. Enter a *Point name*.
3. In the *Method* field, select From a baseline.
4. As shown in the diagram below, enter the names of the start point (1) and the end point (2) of the baseline.
5. Enter a *Distance* and select the *Distance direction* method (5, 6, 7, or 8).
6. Enter the offset distance and select the *Offset direction* (3 or 4).
7. Enter the vertical distance.

Note - The vertical distance is dependent on the Distance direction. If the direction is relative to the start point, the elevation of the computed point is the elevation of the start point plus the vertical distance. Similarly, if the direction is relative to the end point, the elevation of the computed point is the elevation of the end point plus the vertical distance.

8. To calculate the offset point (9), tap *Calc*.

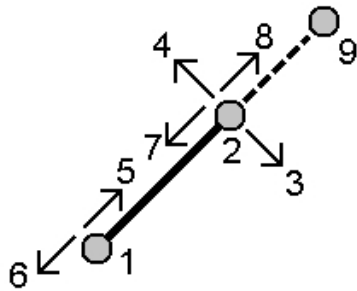

Project point to line

To compute a point at a position along a line that is perpendicular to another point:

1. From the main menu, select *Cogo / Compute point*.
2. Enter a *Point name*.
3. In the *Method* field, select *Project point to line*.
4. Enter the *Point to project* (1).
5. Enter the *Line name* (2) or enter the *Start point* and *End point* to define the line.
6. Tap *Calc*.

The following values are computed:

- coordinates of the point (3)
 - horizontal distance along the line (4)
 - horizontal and slope distance, azimuth, grade, vertical distance, and delta north (5) and east (6) values from the selected point (1) to point (3)
7. Tap *Store* to store the point in the database.

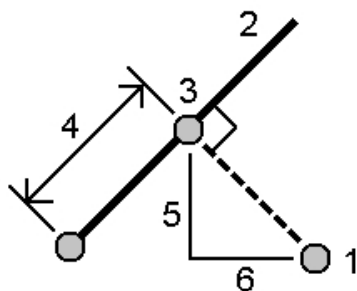

Project point to arc

To compute a point at a position along an arc that is perpendicular to another point:

1. From the main menu, select *Cogo / Compute point*.
2. Enter a *Point name*.
3. In the *Method* field, select *Project point to arc*.

4. Enter the *Point to project* (1).
5. Enter the *Arc name* or key in a new arc.
6. Tap *Calc.*

The following details appear: The coordinates of the point (5), the horizontal distance along the arc (3), and horizontal distance from the arc (4).

7. Tap *Store* to store the point in the database.

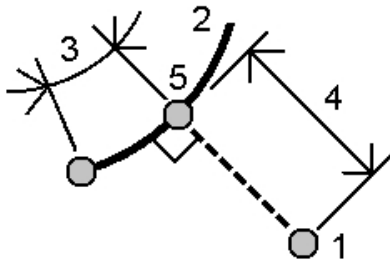

Area calculations

Area calculations is a graphical utility that enables you to compute an area and then to subdivide that computed area. When subdividing areas, new intersection point(s) are computed and stored.

Note - To compute a Surface area you need to use [Compute volume](#).

The following methods can be used to subdivide the area:

- Parallel line
- Hinge point

The easiest way to define the area to be computed and subdivided is to tap and hold the *Area calculations* option from the Map. You can then use the following entities:

- points, lines, and arcs from the current job
- points, lines, arcs, and polylines from active map files
- points from a linked job, CSV and TXT files
- a combination of the above

Note - You can also start *Area calculations* from the *Cogo* menu. However, you can then only use *points* to define the area.

When you select entities to define the area, you must select them in the correct order.

When you select lines, arcs, or polylines, you must select them in the correct direction.

To compute and then subdivide an area enclosed by points displayed in the map:

1. From the map, select the points on the perimeter of the area to be calculated. Use the order that they occur on the perimeter.
2. Tap and hold on the map and then select *Area calculations* from the menu.

The computed area and the perimeter appear. The arrows on the lines indicate the order in which the points were selected.

Note - The computed area varies according to the *Distance* display setting.

3. Do one of the following:

- To store the area, enter a name, if required, and then tap *Store*. The area is saved and you exit *Area calculations*.
- To subdivide the area:
 - a. Tap the subdivide method - *Parallel* or *Hinge*.
 - b. Enter the *New area* to subdivide from the total area.
 - c. If you use the *Parallel* method, tap the line that defines the parallel line.
If you use the *Hinge* method, tap the point that defines the hinge point.
The *New area* that you entered is shaded blue. New points are displayed with a red circle, and labeled Pt1, Pt2, and so on.
 - d. If the subdivided area you require is the complement of the area displayed, tap the *Swap area* button to switch areas.
 - e. Tap *Continue*.
 - f. To store the intersection point(s), enter their name(s) and then tap *Save*.
If you do not want to save the intersection point(s), do not name them.
 - g. Tap *Close*.

To see details about the original area and perimeter, new area and perimeter, new intersection points, and an image of the area, go to *Review job*.

The following figure shows an example of a subdivided area using the *Hinge* method.

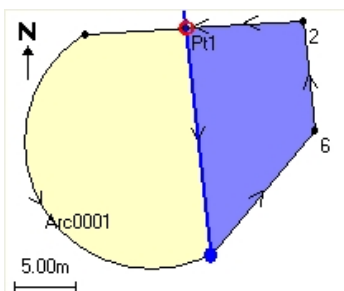

Notes

- In area calculations, you can use polylines from a DXF or STR file, but you cannot use General Survey alignments or roads.
- If lines intersect or cross over, the General Survey software attempts to compute the correct area and subdivide the area, but in some cases may give the wrong results.

Make sure that the graphical image looks correct and then double-check the results if you have concerns that they may not be correct.

Compute volume

You can use Compute Volume to calculate volumes from surfaces stored in Triangulated Terrain Model (*.ttm) files. Import the *.ttm files from your office software or generate them using the

Create surface option from the map in General Survey. The following volume calculation methods are available:

Above an elevation

Void volume

Surface to elevation

Surface to surface

Stockpile/depression

Surface area

Above an elevation

Calculates the volume of a single surface above the specified elevation. Only the cut volume is computed. Haul bulkage can be applied if necessary.

Void volume

Calculates the volume of material needed to fill a surface up to a specified elevation. Shrinkage can be applied if necessary.

Surface to elevation

Calculates the cut and fill volumes between a single surface and a specified elevation. Where the surface is below the elevation, fill will be computed; where the surface is above the elevation, cut will be computed. Haul bulkage and/or shrinkage can be applied if necessary.

Surface to surface

Calculates the cut and fill volumes between two surfaces. The *Initial surface*, is the original surface and *Final surface* is the design surface or surface after excavation. Where the *Initial surface* is above the *Final surface* cut will be computed; where the *Initial surface* is below the *Final surface*, fill will be computed. Haul bulkage and/or shrinkage can be applied if necessary.

Note - Volumes will be computed only in areas where the initial and final surfaces overlap.

Stockpile/depression

This works in a similar way to *Surface to surface* except with only one surface. The selected surface is treated as the final surface and the initial surface is defined from the perimeter points of the selected surface. Where the surface is above the perimeter surface, cut will be computed (stockpile); where the surface falls below the perimeter surface, fill will be computed (depression). Haul bulkage and/or shrinkage can be applied if necessary.

Surface area

Calculates the surface area, and using the specified depth can calculate the volume.

Haul bulkage

A haul bulkage factor allows for the expansion of cut material as it is excavated. Haul bulkage is defined as a percentage. The Adjusted cut volume is the cut volume with the haul bulkage factor applied to it.

Shrinkage

A shrinkage factor allows for compaction in fill material. Shrinkage is defined as a percentage. The Adjusted fill volume is the fill volume with the shrinkage factor applied to it.

Compute distance

Calculate a distance using one of the following methods:

[Between two points](#)

[Between point and line](#)

[Between point and arc](#)

To access *Compute distance*, do one of the following:

- From the *Cogo* menu, tap *Compute distance*.
- From the Cogo [calculator](#), tap *Distance*.
- From the map, select the point and the line or arc and then tap and hold and select *Compute distance*.

Note - If you select two points on the map, *Compute distance* is not available from the tap and hold menu. Select [Compute inverse](#) instead.

You can compute a distance using keyed-in data, points stored in the database, or data in a [map layer](#). For keyed in data or points stored in the database, the compute distance results are stored in the database. For data in a map layer, compute distance results are stored as a note record.

Note - You can enter data in different units. For example, if you add a distance in meters to a distance in feet, the answer is returned in whatever format you specified in the job configuration.

Between two points

In the *Compute distance* screen:

1. Select *Between two points* in the *Method* field.
2. Enter the *From point* and the *To point*.
3. The distance between the two points is calculated.

Tip - You can compute a distance between two points in the database directly in a distance field. To do this, enter the point names in the distance field, separated by a hyphen. For example, to compute the distance between points 2 and 3, enter "2-3". This method works with most alphanumeric point names, but it does not support point names that already contain a hyphen.

Between point and line

In the *Compute distance* screen:

1. Make sure *Between point and line* is selected in the *Method* field.
2. If required, enter the *Point name* (1) and the *Line name* (2) as shown in the diagram below.

Tip - If the line does not already exist, tap the advanced pop-up arrow and select *Two points*. You can then enter the start point and end point to define the line.
3. The distance along the line (3) and the perpendicular distance (4) to the line is calculated. The

distance along the line is from the point specified (5).

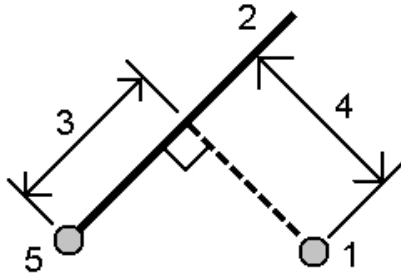

Between point and arc

In the *Compute distance* screen:

1. Make sure *Between point and arc* is selected in the *Method* field.
2. If required, enter the *Point name* (1) and the *Arc name* (2) as shown in the diagram below.
3. The distance along the arc (3) and the perpendicular distance (4) to the arc is calculated. The distance along the arc is from the point specified (5).

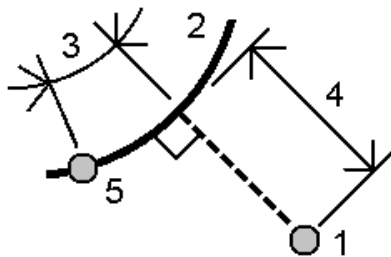

Compute azimuth

You can use keyed-in data, and points stored in the database, to calculate an azimuth by various methods. You can also store the results in the database. For some methods, you have to tap *Calc* to display the results.

The data that you enter can have different units. For example, you can add an angle in degrees to an angle in radians - the answer is returned in whatever format you specified in the job configuration.

Calculate an azimuth using one of the following methods:

- [Between two points](#)
- [Bisected azimuths](#)
- [Bisected corner](#)
- [Azimuth plus angle](#)
- [Azimuth to line offset](#)

Between two points

To calculate the azimuth between two points:

1. From the main menu, select *Cogo / Compute azimuth*.
2. In the *Method* field, select *Between two points*.
3. As shown in the diagram below, enter the name of the From point (1) and the To point (2).
4. The azimuth between them (3) is calculated.

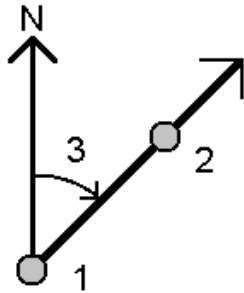

Tip - You can compute an azimuth from two points in the database directly in an azimuth field. To do this, enter the point names in the *Azimuth* field, separated by a hyphen. For example, to compute the azimuth from point 2 to point 3, enter "2-3". This method works with most alphanumeric point names, but it does not support point names that already contain a hyphen.

Bisected azimuths

To calculate bisected azimuths:

1. From the main menu, select *Cogo / Compute azimuth*.
2. In the *Method* field, select *Bisected azimuths*.
3. As shown below, enter values for *Azimuth 1* (1), and *Azimuth 2* (2).

The following calculations appear: The computed azimuth halfway between them (3), and the computed angle, measured clockwise between azimuth 1, and azimuth 2.

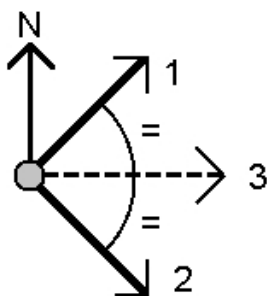

Bisected corner

To calculate a bisected corner azimuth:

1. From the main menu, select *Cogo / Compute azimuth*.
2. In the *Method* field, select Bisected corner.
3. As shown below, enter the names of the *Side point 1* (1), the *Corner point* (3), and *Side point 2* (2).

The following values are computed:

- azimuth (4), halfway between Side point 1 and Side point 2, from the Corner point (3)
- inside angle (5) and outside angle (6)
- distance from the corner point to the two side points and the distance from one side point to the other
- azimuth from the corner point to the two side points
- angle between the corner point and each side point, as well as the opposite angle (7)

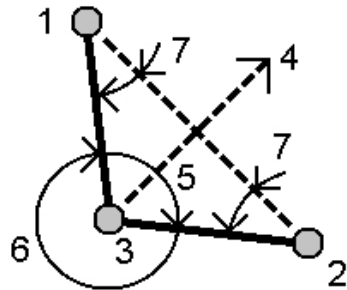

Azimuth plus angle

To calculate the azimuth plus angle:

1. From the main menu, select *Cogo / Compute azimuth*.
2. In the *Method* field, select Azimuth plus angle.
3. As shown in the diagram below, enter the *Azimuth* (1) and the *Turned angle* (2).
4. The sum of the two (3) is calculated.

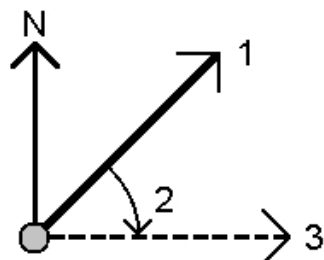

Azimuth to line offset

To calculate the azimuth to line offset:

1. From the main menu, select *Cogo / Compute azimuth*.
2. In the *Method* field, select Azimuth to line offset.
3. As shown below, enter the name of the line (1), the station (2) and the horizontal offset (3).

The following calculations appear: The computed azimuth (4), from the start point of the line to the offset point, and the computed angle, measured clockwise between the line (1), and the Azimuth (4).

Tip - If the line does not already exist, tap the advanced pop-up arrow and then select *Two points*. You can then enter the start point and end point to define the line.

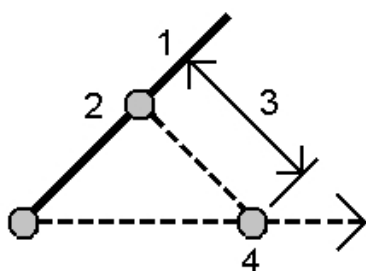

Compute average

Use the *Compute average* option to compute and store the average position for a point that has been measured more than once.

Two or more angles only observations from two different known points can be 'averaged' to compute the coordinates of the intersection point. To 'average' the observations they must be stored with the same point name.

Enter the name of the point to compute the average position for into the *Point name* field. You can select the point name from a list using the [pop-up menu](#) for the field.

If the point you entered has only one position fix, or has been stored as a control point, then an error message appears to tell you that an average position cannot be computed.

Once you enter a point name for which an average position can be computed, General Survey searches the database to find all the positions for that point. Once computed, the average point grid position appears, along with the standard errors for each ordinate.

If there are more than two positions for the point, a *Details* softkey appears. Tap *Details* to view the residuals from the average position to each individual position. You can use this residuals form to include or exclude specific positions from the average computation.

Tap *Options* to select the averaging method. Two methods are supported:

- Weighted
- Unweighted

Tip - General Survey averages all positions in the current job database with the same name (except Control points). Tap *Details* to ensure that only the required positions are averaged.

To store the computed average position for the point, tap *Store*. If an averaged position for the point already exists in the database, the existing point is automatically deleted when the new average position is stored.

Notes

- *An averaged position is not automatically updated if the positions used to compute the average are changed. For example, if the calibration is updated, if observations are transformed or deleted, or if new observations of the same name are added, re-compute the averaged position.*
- *Averaging uses Least squares to average points/observations in the current job that have the same name.*
 - *If the average includes anything other than ECEF or WGS84 positions, the average is stored as a grid.*
 - *GNSS observations and conventional observations that include a measured slope distance are resolved to grid and then averaged using Least squares. The intersections of angles only conventional observations are averaged using Least squares.*
 - *Conventional angle-only observations are only added to the solution if there are no other positions or observations.*
 - *When the average includes only ECEF or WGS84 positions, the averaged grid position is converted back to WGS84 and stored as a WGS84. When the average contains only grid positions and conventional observations, or a mixture of position types, then the averaged grid position is stored as a grid.*
- *Any Mean Turned Angle (MTA) observed to the point is ignored and the original observations are used to compute the average position.*
- *If Weighted is selected, points in an average are weighted as follows:*
 - *GNSS positions use the horizontal and vertical precisions of the observations. Observations that do not have precisions, and keyed-in points, use 10 mm for horizontal and 20 mm for vertical.*
 - *For conventional observations that include a measured slope distance, horizontal and vertical standard errors are computed based on the standard errors of the components of the observation.*
The standard error used for weighting the horizontal position is a combination of those used for the horizontal direction and horizontal distance weights from the resection calculation. For more information, see [Resection Computations] at www.trimble.com/Survey/Trimble-Access-IS.aspx.
- *To automatically average duplicate points, enable Auto average in the [Duplicate point tolerance](#) section of the survey style.*

Arc solutions

Use arc solutions to:

- **Calculate** arc solutions when two parts of the arc are known, and to view the results as both text and graphics.
- **Compute** points on the arc.
- **Add** the arc, and the points defining the arc, to the database.

Calculate arc solutions

Use the two *Method* fields to set the entry type for the arc values you have.

The first known part of the arc is defined by one of the following:

- Radius - is the radius of the arc.
- Delta - is the delta or deflection angle.
- Degree arc - is the deflection angle (delta) that results in an arc length of 100 units.
- Degree chord - is the deflection angle (delta) that results in a chord length of 100 units.

The second known part of the arc is defined by one of the following:

- Delta - is the delta or deflection angle.
- Length - is the arc length.
- Chord - is the chord length.
- Tangent - is the distance from the PC or PT to the PI.
- External - is the shortest distance between the Point of Intersection (PI) and the arc.
- Mid ordinate - is the distance between the arc and the chord at the mid point of the arc.

Results

Tap *Calc* to view the results for the horizontal arc, and a graphical view of the arc.

Entered data appears as black text; computed data appears as red text.

See the following figure for details on the values that are computed for an arc.

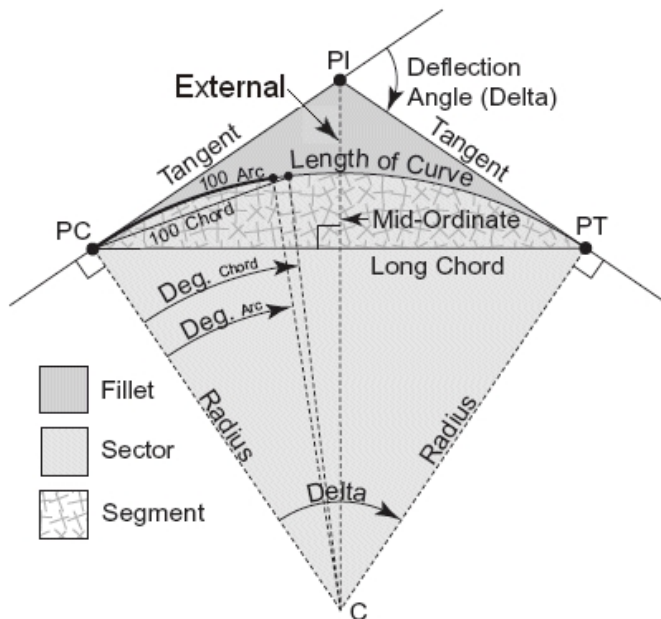

- Radius - is the radius of the arc.
- Arc length - is the arc length.
- Chord length - is the chord length.
- Degree arc - is the deflection angle (delta) that results in an arc length of 100 units.
- Degree chord - is the deflection angle (delta) that results in a chord length of 100 units.
- Delta - is the delta or deflection angle.
- Tangent - is the distance from the PC or PT to the PI.
- External - is the minimum distance between the PI and the arc.
- Mid ordinate - is the distance between the arc and the chord at the mid point of the arc.
- Segment area - is the area between the arc and the chord.
- Sector area - is the area between the arc and the two edge radii.
- Fillet area - is the area between the arc and the tangents.

Compute points on the arc

Tap *Layout* to compute points on the arc at any station along the arc.

You can select from the following methods:

- [PC deflection](#)
- [PI deflection](#)
- [Tangent offset](#)
- [Chord offset](#)

When viewing any of the arc or layout computation results, tap *Store* to save the results in the current job.

To remove the Layout fields from the screen, tap *Arc*.

PC deflection

Provides the deflection angle and distance to each specified station on the arc as if you are occupying the PC point and backsighting the PI point.

Tap *Calc* to view the computed arc with these additional details:

- Station - is the specified station along the arc.
- Deflection - is the deflection angle from the tangent line (PC point to PI point) to the current station point on the arc.
- Chord - is the distance to the current station point on the arc from the PC point.
- Previous station - is the previously specified PC deflection station.

This is available only if the immediately previous point was computed using the PC deflection method.

- Short chord - is the chord distance from the current PC deflection point on the arc to the previous PC deflection point on the arc.

This is available only if the immediately previous point was computed using the PC deflection method.

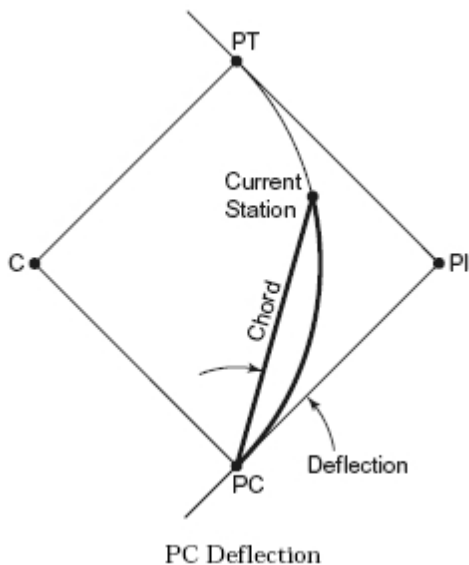

PI deflection

Provides the deflection angle and distance to each specified station on the arc as if you are occupying the PI point and backsighting the PC point.

Tap *Calc* to view the computed arc with these additional details:

- Station - is the specified station along the arc.
- Deflection - the deflection angle from the incoming tangent line to the current station point on the arc.
- PI to station - the distance to the current station point on the arc from the PI point.

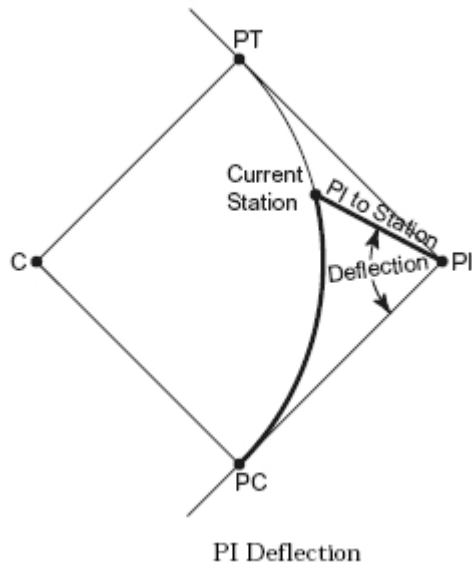

Tangent offset

Provides the perpendicular offset information from the tangent line (the line from the PC point to the PI point) to each specified station on the arc.

Tap *Calc* to view the computed arc with these additional details:

- Station - is the specified station along the arc.
- Tangent dist (TD) - is the distance along the tangent line from the PC point toward the PI point where the perpendicular offset to the arc point occurs.
- Tangent offset - is the perpendicular offset distance from the tangent line to the current station point on the arc.
- Tangent - is the length of the tangent line (the distance from the PC point to the PI point).
- Tangent - TD - is the remainder distance along the tangent line (the distance from the point of

the perpendicular offset to the PI point).

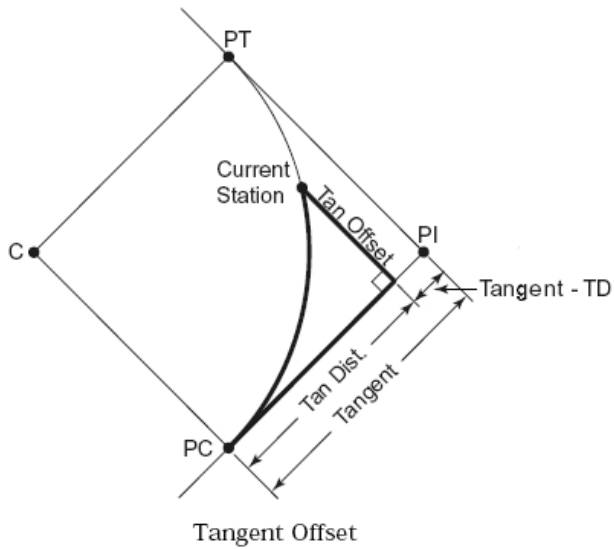

Chord offset

Provides the perpendicular offset information from the long chord (the line from the PC point to the PT point) to each specified station on the arc. The PC deflection information is also provided.

Tap *Calc* to view the computed arc with these additional details:

- Station - is the specified station along the arc.
- Chord dist - is the distance along the long chord from the PC point (toward the PT point) where the perpendicular offset to the arc point occurs.
- Chord offset - is the perpendicular offset distance from the long chord to the current station point on the arc.
- PC Deflection - is the deflection angle from the tangent line (PC point to PI point) to the current station point on the arc.

- Chord length - is the distance to the current station point on the arc from the PC point.

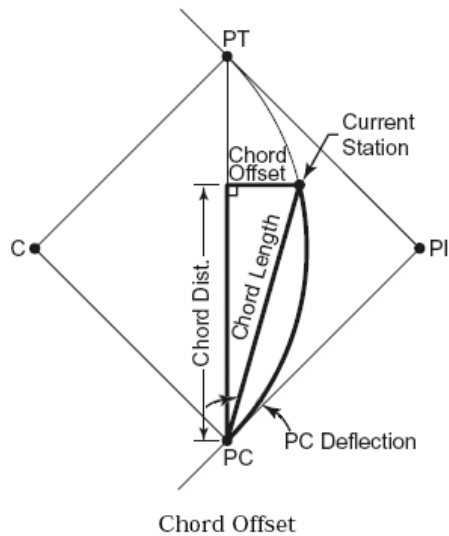

Add the arc and the points defining the arc

Tap *Add* to add to the database the:

- calculated arc
- point defining the end point of the arc
- point defining the center point of the arc

Note - Before you can add these to the database, you must select a start point for the arc, a back tangent, and the back tangent direction.

Triangle solutions

You can use keyed-in data to calculate a triangle by various methods. You can then view the results as both text and graphics, and store the results in the database.

Calculate a triangle using one of the following methods:

Side-Side-Side

Define a triangle by entering the distances for sides a, b, and c. Tap *Calc* to view the results.

Angle-Side-Angle

Define a triangle by entering angle A, the distance for side b, and angle C. Tap *Calc* to view the results.

Side-Angle-Angle

Define a triangle by entering the distance for side a, angle B, and angle A. Tap *Calc* to view the results.

Side-Angle-Side

Define a triangle by entering the distance for side a, angle B, and the distance for side c. Tap *Calc* to view the results.

Side-Side-Angle

Define a triangle by entering the distances for sides a and b, and angle A. Tap *Calc* to view the results.

Results

Tap *Calc* to view the results including the lengths of sides a, b, and c, the angles of A, B, and C, the area of the triangle, and a graphical view of the triangle.

Entered data appears as black text; computed data appears as red text.

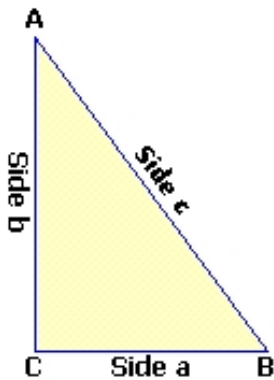

In some situations, there may be two solutions to a triangle. When this occurs, an *Other* softkey is available in the result screen. Tap *Other* to toggle between the two possible solutions so that you can select the correct one. Tap *Store* to record the triangle results in the current job.

Subdivide a line

Use this function to subdivide a line into segments. The points created are automatically stored in the database and the point names are automatically incremented from the Start point name.

You can predefine the code of a subdivided point. For more information, see [Subdivide pts code](#).

Subdivide a line using one of the following methods:

[Fixed segment length](#)

[Fixed number of segments](#)

Tip - If the line does not already exist, tap the advanced pop-up arrow and then select *Two points*. You can then enter the start point and end point to define the line.

Fixed segment length

To subdivide a line into segments of fixed length:

1. Do one of the following:
 - From the map, select the line to be subdivided (1). Tap and hold on the screen and then select the *Subdivide a line* option from the shortcut menu.
 - From the main menu, select *Cogo / Subdivide a line*. Enter the name of the defined line.
2. In the *Method* field, select Fixed segment length.
3. Enter the segment length (2), and any horizontal offset (3) and vertical offset from the line.
4. Enter the names of the *Start at station* (4), the *End at station* (5), and the *Start point name*.
5. Tap *Start* to calculate the new points (4, 6, 7, or 8, 9, 10).

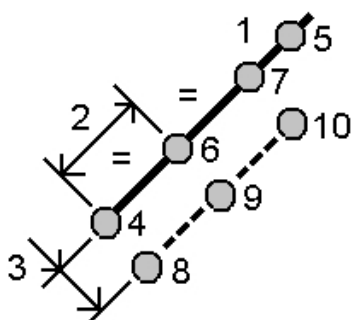

Fixed number of segments

To subdivide a line into a fixed number of segments:

1. Do one of the following:
 - From the map, select the line to be subdivided. Tap and hold on the screen and then select the *Subdivide a line* option from the shortcut menu.
 - From the main menu, select *Cogo / Subdivide a line*. Enter the name of the defined line.
1. In the *Method* field, select Fixed number of segments.
2. Enter the number of segments, and any horizontal offset (2) and vertical offset from the line.
3. Enter the names of the *Start at station* (3), the *End at station* (4), and the *Start point name*.
4. Tap *Start* to calculate the new points (3, 5, 4, or 6, 7, 8).

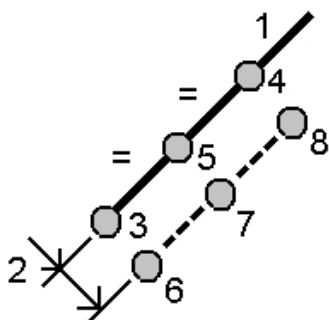

Subdivide an arc

Use this function to subdivide an arc using one of the following methods:

Fixed segment length

Fixed number of segments

Fixed chord length

Fixed angle subtended

The points created are automatically stored in the database and the point names are incremented from the Start point name.

You can predefine the code of a subdivided point. For more information, see [Subdivide pts code](#).

Fixed segment length

To subdivide an arc into segments of fixed length:

1. Do one of the following:
 - From the map, select the arc to be subdivided. Tap and hold on the screen and select the *Subdivide an arc* option from the shortcut menu.
 - From the main menu, select *Cogo / Subdivide an arc*. Enter the name of the defined arc.
2. In the *Method* field, select Fixed number of segments.
3. Enter the segment length (2), and any horizontal offset (3) and vertical offset from the arc.
4. Enter the names of the *Start at station* (4), the *End at station* (5), and the *Start point name*.
5. Tap *Start* to calculate the new points (4, 6, 7, or 8, 9, 10).

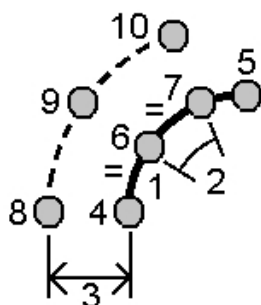

Fixed number of segments

To subdivide an arc into a fixed number of segments:

1. Do one of the following:
 - From the map, select the arc to be subdivided. Tap and hold on the screen and select the *Subdivide an arc* option from the shortcut menu.
 - From the main menu, select *Cogo / Subdivide an arc*. Enter the name of the defined arc.
2. In the *Method* field, select Fixed number of segments.
3. Enter the number of segments, and any horizontal offset (2) and vertical offset from the arc.

4. Enter the names of the *Start at station* (3), the *End at station* (4), and the *Start point name*.
5. Tap *Start* to calculate the new points (3, 5, 4, or 6, 7, 8).

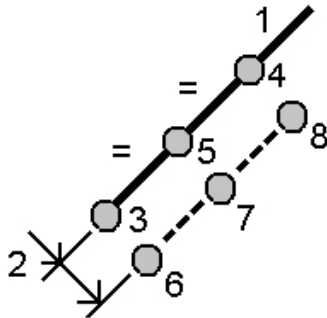

Fixed chord length

To subdivide an arc into segments of fixed chord length:

1. Do one of the following:
 - From the map, select the arc to be subdivided. Tap and hold on the screen and select the *Subdivide an arc* option from the shortcut menu.
 - From the main menu, select *Cogo / Subdivide an arc*. Enter the name of the defined arc.
2. In the *Method* field, select Fixed chord length.
3. Enter the chord length (2), and any horizontal offset (3) and vertical offset from the arc.
4. Enter the names of the *Start at station* (4), the *End at station* (5), and the *Start point name*.
5. Tap *Start* to calculate the new points (4, 6, 7, or 8, 9, 10).

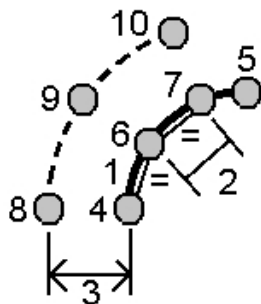

Fixed angle subtended

To subdivide an arc into fixed angle subtended segments:

1. Do one of the following:
 - From the map, select the arc to be subdivided. Tap and hold on the screen and select the *Subdivide an arc* option from the shortcut menu.
 - From the main menu, select *Cogo / Subdivide an arc*. Enter the name of the defined arc.
2. In the *Method* field, select Fixed angle subtended.
3. Enter the *Angle subtended* (2), and any horizontal offset (3) and vertical offset from the arc.
4. Enter the names of the *Start at station* (4), the *End at station* (5), and the *Start point name*.

5. Tap *Start* to calculate the new points (4, 6, 7, or 8, 9, 10).

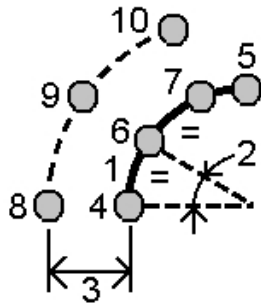

Transformations

Use this Cogo function to do one of the following:

- Transform a single point, or a selection of points, using one or a combination of [rotation](#), [scale](#), or [translations](#).
- Create or edit a [local transformation](#) that can be applied to Grid (local) points to transform the Grid (local) points to Grid points.

Note - Local transformation support is available only when the [Advanced Geodetic](#) option is enabled.

Transformations can be applied and used in a number of places throughout the General Survey software:

- [Key in points](#)
- [Linked files](#)
- [Stakeout points](#) from a linked CSV or TXT file
- [Review job](#)
- [Point manager](#)
- [Import fixed format files](#) from a comma delimited file
- [Export Grid \(local\)](#)

Tips

- Use *Cogo / Transformations / Manage/Define local transformations* to create or edit transformations. See [Local transformations](#).
- Use *Point manager* to select a different input transformation.
- Use *Jobs / Copy between jobs* to copy transformations to other jobs.

Rotate, scale, and translate points

Rotate, scale, and translate changes the stored coordinates of the points that are transformed. This method saves new transformed points and then deletes the original points.

When performing more than one transformation, the order is always rotate, scale, then translate.

Notes

- Only points that can be displayed as grid coordinates can be transformed.
- When transforming by both rotate and scale, the origin for the scale defaults to the origin for the rotate. You can change this.
- Points selected in the map automatically populate the list of points to be transformed.
- When entering a point name, you can select from the list, key in a point, perform a fast fix, measure a point, or make a map selection. Fast fix stores an automatic rapid point with a temporary point name.

Warning - If you select a base point to be transformed, then vectors flowing from this base become null.

Rotate

To rotate a selection of points about a specified origin point:

1. From the main menu, select *Cogo / Transformations*.
2. Select *Rotate / scale / translate points* and then tap *Next*.
3. Set the *Rotate* check box, then tap *Next*.
4. Enter an *Origin point*.
5. Enter a *Rotation* or, to compute the rotation as the difference between two azimuths, select *Two azimuths* from the pop-up menu.
6. Tap *Next* and then **select** the point(s) to rotate.
7. To store the transformed point(s) to the database, tap *Accept*.

A transformation deletes the original point(s) and stores new grid points of the same name.

Scale

To scale the distances between the origin point and the selected points:

1. From the main menu, select *Cogo / Transformations*.
2. Select *Rotate / scale / translate points* and then tap *Next*.
3. Set the *Scale* check box, then tap *Next*.
4. Enter an *Origin point*.
5. Enter a *Scale factor*.
6. Tap *Next*, then **select** the point(s) to scale.
7. To store the transformed point(s) to the database, tap *Accept*.

A transformation deletes the original point(s) and stores new grid points of the same name.

Translate

To move a selection of points on a grid surface:

1. From the main menu, select *Cogo / Transformations*.
2. Select *Rotate / scale / translate points* and then tap *Next*.
3. Set the *Translate* check box, then tap *Next*.

4. In the *Method* field, select either Deltas or Two points.

If you choose Deltas:

- Enter a delta Northing, Easting, and/or Elevation. You can select a single delta, for example a Northing, or any combination of deltas for the transformation.

If you choose Two points:

- a. Select a *From point*.
 - b. Select a *To point*.
5. Tap *Next*, then **select** the point(s) to transform.
 6. To store the transformed point(s) to the database, tap *Accept*.

A transformation deletes the original point(s) and stores new grid points of the same name.

Local transformations

There are often occasions in surveying where existing points to be tied into or staked out have grid coordinates defined in one or more coordinate or reference systems, which are different from the current job's coordinate system. These other coordinate or reference systems may be defined based on old base lines where the coordinates are effectively station and offset values from the base (reference) line. Or they may be referenced to a completely arbitrary reference system. For example, an architect may provide coordinates for a building foundation that needs to be positioned and transferred into a real coordinate system on site.

General Survey lets you compute and store one or more local transformations that will transform on-the-fly between the grid coordinates and sets of local grid coordinates.

Unlike Rotate, Scale, and Translate, the position of transformed points is not changed. Instead, points can be created as Grid (local), and a relationship to Grid is defined that provides the transformation to the local coordinate system.

Note - *Grid (local) points cannot be displayed in the map if a transformation to grid has not been defined.*

There are three types of local grid transformations that can be created and used throughout General Survey:

[Line transformations](#)

[Helmert transformations](#)

[Seven parameter transformations](#)

Note - *Local transformation support is available only when the [Advanced Geodetic](#) option is enabled.*

A point stored as a Grid (local) can only ever have one 'input' transformation that defines the relationship to database Grid positions. However, when viewing with Review job or Point manager, and when exporting as Grid (local), you can select a different local transformation, which changes the displayed computed Grid (local) coordinates.

This powerful function enables you to, for example, key in a Grid (local) point referenced to one baseline or reference system, and transform to the database grid, and then, if required, use another 'display' transformation to display the point with computed Grid (local) values referenced

to a different baseline or reference system. This is analogous to how any point can be displayed as station and offset to any line, arc, alignment, or road.

Line transformations

The *Line* transformation type is a 2D transformation that allows you to select or key in two database grid points and match them up with the local grid coordinates for the same positions.

To create a line transformation:

1. From the main menu, tap *Cogo / Transformations / Manage & define transformations* and then tap *Next*.
2. Select *Create new transformation*, and then tap *Next*.
3. Set the *Transformation type* to *Line* and then enter the *Transformation name*.
4. In the *Start point* field, enter the name of the point and then enter the corresponding Grid (local) coordinates in the *North (local)* and *East (local)* fields.
5. In the *End point* field, enter the name of the point and then enter the corresponding Grid (local) coordinates in the *North (local)* and *East (local)* fields.
6. Tap *Calc*, check the computed transformation distances and then select a *Scale factor type* to fit the local grid positions to the database grid positions:
 - Free - The computed scale factor is applied to the Grid (local) values in both local axes.
 - Fixed to 1.0 - No scaling is applied. (The Grid (local) values are used in the transformation with no scaling applied to them.)

The start point is the origin point of the transformation.

 - Along the local northing axis only - The computed scale factor is applied to the Grid (local) northing values only during the transformation.
7. Tap *Store* to store the transformation to the current job.

The line transformation appears in the map as a black dashed line between the start grid point and the end grid point.

Use [Filter](#) to enable and disable the display of line transformations.

Note – ‘Grid points’ do not have to be stored as grid points, but General Survey needs to be able to compute grid coordinates for the point.

Helmert transformations

The *Helmert* transformation type can be a 2D or 3D transformation that allows you to select up to 20 identical point pairs to compute a best fit transformation between the database grid points and the local grid coordinates for the same positions.

To create a Helmert transformation:

1. From the main menu, tap *Cogo / Transformations / Manage & define transformations* and then tap *Next*.
2. Select *Create new transformation* and then tap *Next*.
3. Set the *Transformation type* to *Helmert* and then enter the *Transformation name*.
4. Set the *Scale factor type* to one of the following:

- Free - The computed best fit scale factor is used in the transformation.
 - Fixed, and then enter the Scale factor - Specify your own scale factor to be used in the transformation.
5. Set the Vertical adjustment to one of the following and then tap *Next*:
 - None - No vertical adjustment is carried out.
 - Constant adjustment only - The average vertical correction computed from the elevations of the point pairs is used for vertical adjustment in the transformation.
 - Inclined plane - A vertical correction plus a best fit correction plane is used for vertical adjustment in the transformation.
 6. Tap *Add* to select the *Grid point name* and *Local grid point name* pairs of points and then set the *Use* field to one of the following:
 - Off - Do not use this point pair in the computation of the transformation parameters.
 - Vertical only - Use this point pair only in the computation of the vertical adjustment parameters.
 - Horizontal only - Use this point pair only in the computation of the horizontal adjustment parameters.
 - Horizontal & vertical - Use this point pair in the computation of both the horizontal and the vertical adjustment parameters.
 7. Tap *Accept* to add the pair to the list and then tap *Add* again to add more pairs of points.
 8. Tap *Results* to see the Helmert transformation results.
 9. Tap *Store* to store the transformation to the current job.

Notes

- *To edit a transformation, follow the steps to create a new transformation, but at step 2, select Select transformation to edit, select the required transformation from the list, tap Next, update the transformation parameters as required, check the results and then tap Store to overwrite the previous transformation.*
- *If you change a transformation, the position of all points using that transformation also changes.*
- *If you change the coordinates of a point used to define a Helmert transformation, General Survey does not automatically recompute the transformation.*
- *If you change the coordinates of a point, and then recompute the Helmert transformation the new transformation uses the new coordinates.*

Seven parameter transformations

The *Seven parameter* transformation type is a 3D transformation that allows you to select up to 20 identical point pairs to compute a best fit transformation between the database grid points and the local grid coordinates for the same positions.

A seven parameter transformation will provide a better solution than a Helmert transformation if the two coordinate systems are not defined with respect to the same horizontal plane.

To create a seven parameter transformation:

1. From the main menu, tap *Cogo / Transformations / Manage & define transformations* and then tap *Next*.
2. Select *Create new transformation* and then tap *Next*.
3. Set the *Transformation type* to *Seven parameter* and then enter the *Transformation name*.
4. Tap *Add* to select the *Grid point name* and *Local grid point name* pairs of points and then set the *Use* field to one of the following:
 - *Off* - Do not use this point pair in the computation of the transformation parameters.
 - *Horizontal & vertical* - Use this point pair in the computation of the adjustment parameters.
5. Tap *Accept* to add the pair to the list and then tap *Add* again to add more pairs of points.
6. Residuals will only start to be displayed once 3 point pairs have been defined.
7. Tap *Results* to see the Seven parameter transformation results.
8. Tap *Store* to store the transformation to the current job.

Notes

- *The Seven parameter transformation is a three dimensional transformation only. You cannot use 1D or 2D points in the point pairs used to compute the transformation parameters.*
- *If a Seven parameter transformation is applied to 1D or 2D Grid, or Grid (local) point, the transformed position will have null coordinates.*
- *To edit a transformation, follow the steps to create a new transformation, but at step 2, select *Select transformation to edit*, select the required transformation from the list, tap *Next*, update the transformation parameters as required, check the results and then tap *Store* to overwrite the previous transformation.*
- *If you change a transformation, the position of all points using that transformation also changes.*
- *If you change the coordinates of a point used to define a Seven parameter transformation, General Survey does not automatically recompute the transformation.*
- *If you change the coordinates of a point, and then recompute the Seven parameter transformation the new transformation uses the new coordinates.*

Traverse

Use this function to calculate a traverse misclosure, and adjust a conventional traverse. The software helps you select the points to be used, calculates the misclosure, and then lets you compute either a Compass or Transit adjustment.

Note - *The Compass adjustment is sometimes known as the Bowditch adjustment.*

You can calculate closed-loop traverses and closed traverses that start and end on pairs of known points.

To calculate a traverse:

1. Enter the *Traverse name*.
2. In the *Start station* field, tap *List*.
3. Select a point from the list of valid traverse points that can be used as the start station. Tap *Enter*.

A valid start station has one or more backsights and one or more observations to the next traverse station.

4. Tap *Add* to add the next point in the traverse.
5. Select the next station in the traverse.

A valid traverse station has one or more backsight observations to the previous traverse station, and one or more observations to the next traverse station. When there is only one valid traverse station, it is added automatically.

Note - *To view the observed azimuth and distance between two points in the list, highlight the first point and tap the Info softkey.*

6. Repeat steps 4 and 5 until all points in the traverse have been added.

A valid end station has one or more backsights, and one or more observations to the previous traverse station.

If you need to remove any points from the list, highlight the point and tap *Remove*. When you remove a point, all points after it are removed as well.

7. Tap *Close* to compute the traverse misclosure.

Notes

- *You cannot add more points after selecting a control point, or a station with more than one backsight.*
- *To compute a traverse closure, there must be at least one distance measurement between successive points in the traverse list.*
- *The Azimuth fields do not have to be completed.*

If the backsight azimuth is null:

- the traverse cannot be oriented.
- adjusted coordinates cannot be stored.
- an angular adjustment cannot be computed on an open traverse. (A distance adjustment can be computed.)

If the foresight azimuth is null in a loop traverse, and if all angles have been observed, you can compute an angular and distance adjustment.

The backsight and foresight points that provide the orientation for the traverse are shown.

If necessary, tap *Enter* to edit the fields as follows:

1. Inspect the results of the traverse and do one of the following:
 - To store the closure results, tap *Store*.
 - To adjust the traverse, go to the next step.
2. Tap *Options* to check the traverse settings. Make any changes as required, then tap *Enter*.

3. Tap *Adj. Ang.* to adjust the angular misclosure. The angular misclosure is distributed according to the setting in the *Options* screen.
4. Inspect the results of the traverse, then do one of the following:
 - To store the angular adjustment details, tap *Store*.
 - To adjust the distance misclosure, tap *Adj. dist.* The distance misclosure is distributed according to the setting in the *Options* screen and the traverse is stored.

When the traverse is stored, each point used in the traverse is stored as an adjusted traverse point with a search classification of adjusted. If there are any previously adjusted traverse points of the same name, they are deleted.

Taped distances

Use this function to add points to your General Survey job. Use a graphical right angle and distance interface to define rectangular structures, such as a building or building foundations. Key in or measure two points to define the first side, orientation, and location of the object.

Tip - To select the elevation from the Start point or End point, use the pop-up menu in the *Elevation* field.

To select the direction for your next point graphically on the plan view, tap the screen or use the right and left arrow keys. The dashed red line shows the current direction for the next side. To create the next side, tap *Add*, and then enter the distance to the next point using the angle defined in the plan view. Alternatively, select a point that already exists in your job and the software will calculate the distance to that point for you.

To measure a point using GNSS or Conventional, select *Fastfix* or *Measure* from the pop-up menu on the *Point name* field.

To measure distances using a laser rangefinder, you must first connect the laser rangefinder to the controller and configure the laser rangefinder in your survey style. For more information, see [Configuring a survey style to use a laser rangefinder](#). If the *Auto measure* field in the survey style *Laser rangefinder* option is set to *Yes*, the General Survey software instructs the laser to take a measurement when you tap *Laser*. To insert a distance into a *Length* or *H. Dist* field, tap *Laser* from the pop-up menu and measure the distance with the laser. See also [Measuring points with a laser rangefinder](#).

To close the object back onto the start point, tap *Close*. A horizontal distance will be computed and displayed. Use this as a check against your plan or your taped distance. To complete the function, tap *Store*. To add further sides to the object, tap *Add*.

Tip - If you need more detailed information on the quality of the close, use a different point name for the end point, and store the object. Then compute an inverse between the start point and the end point.

To change a keyed in distance before the feature is stored, tap *Edit*, and then select the end point of the side to edit. When you adjust the distance, the plan view updates. You can then continue to add more sides.

Notes

- Once the feature has been stored, you can no longer edit the lengths of the sides.
- The orientation is defined by the first side. Only parallel or 90° angles can be added from this side. To use a different angle, store the object, and then create a new side.
- Because new points are stored as polars, taped distances will not work without a Scale factor only or fully defined Projection in the coordinate system.
- In addition to the new points that are created, lines are created automatically and stored to the General Survey database. These are visible in the map and can be used to stake out lines.

Calculator



To use the calculator at any time, select *Cogo / Calculator* from the main General Survey menu.

Tap (Options) to set the angle method, calculator mode (Reverse Polish Notation (RPN) or Standard), and decimal place display.

Tap *Azimuth* to compute an azimuth.

Tap *Distance* to compute a distance.

The calculator functions are shown below.

Calculator symbol	Function
+	Add
-	Subtract
x	Multiply
÷	Divide
+/-	Change sign of number being entered
=	Equals
π	Pi
	Enter
	Show all values on the stack
	Back space
<input checked="" type="checkbox"/>	Options
y^x	Raise Y to the power of X
x^2	Square
\sqrt{x}	Square root
10^x	Raise 10 to the power of X

Calculator symbol	Function
E^{\pm}	Enter exponent or change exponent sign
$1/x$	Reciprocal
$x \leftrightarrow y$	Swap X with Y
SIN	Sine
SIN^{-1}	Arc Sin
COS	Cosine
COS^{-1}	Arc Cosine
TAN	Tangent
TAN^{-1}	Arc Tangent
LOG	Log base 10
SHIFT	Switch SHIFT state
{	Open parenthesis
}	Close parenthesis
C	Clear all
CE	Clear entry
Mem	Memory functions
P>R	Polar to rectangular coordinate conversion
R>P	Rectangular to polar coordinate conversion
R↓	Rotate stack down
R↑	Rotate stack up
° ' "	Insert degrees, minutes, or seconds separator
DMS-	Subtract angles of the form DD.MMSSsss
DMS+	Add angles of the form DD.MMSSsss
>D.dd	Convert from DD°MM'SS.sss or DD.MMSSsss to angle units
>DMS	Convert from current angle units to DD°MM'SS.sss

Tip - You can access the calculator from the pop-up arrow on most distance fields.

When accessing the calculator with the pop-up arrow, if the numeric field already contained a number that number is automatically pasted into the calculator. At the end of the calculator operations the last solution is pasted back into the numeric field when *Accept* is selected.

1. Select *Calculator* from the pop-up menu.
2. Enter the numbers and functions.
3. Tap = to calculate the result.
4. Tap *Accept* to return the result to the field.

Pop-up menu controls

To insert a feature name into a field, enter the name or tap the pop-up menu button  and select one of the following options from the list that appears:

Select...	To...
List	select features from the database
Key in	key in details
Measure	measure a point
Fast fix	automatically measure a construction class point
Map selections	select from a list of the features currently selected in the map
Calculator	shortcut to the Calculator
Units	select units for the field

To change the method of data entry, tap the advanced pop-up menu button . The first two or three fields change.

Survey – General

Measuring and staking out

Use the *Measure* and *Stakeout* menus to measure and stake out points using the [survey styles](#) defined in the General Survey software.

All surveys in General Survey are controlled by a **survey style**. Survey styles define the parameters for configuring and communicating with your instruments, and for measuring and storing points. This whole set of information is stored as a template and used each time you start a survey.

If the defaults do not suit your needs, modify the style. To do this, tap *Settings* from the Trimble Access menu and then tap *Survey styles*.

To measure or stake out, the General Survey software needs to start a survey, at which time you are prompted to select the appropriate survey style.

Note - *If there is only one survey style, it is automatically selected when you start a survey. Otherwise, select a style from the list that appears.*

For more information, see:

[Measuring points in a conventional survey](#)

[Measuring points in a GNSS survey](#)

[Stakeout – Overview](#)

Survey types

The survey type you use will depend on available equipment, field conditions, and the results required. Configure the survey type when you create or edit a survey style.

In a **conventional survey**, the controller is connected to a conventional survey instrument such as a total station. For more information, see [Conventional surveys: Getting started](#).

In a **GNSS survey**, the controller is connected to a GNSS receiver. For more information, see [GNSS surveys: Getting started](#).

In an **integrated survey**, the controller is connected to both a conventional survey instrument and a GNSS receiver at the same time. The General Survey software can quickly switch between the two instruments, within the same job. For more information, see [Integrated surveys](#).

Getting connected

The General Survey software can automatically connect to Trimble GNSS and conventional instruments.

To auto-connect to a Trimble instrument, the software cycles through a set of connection protocols for each type of instrument. It can take up to 15 seconds to complete the cycle, which means it can take up to 15 seconds to automatically connect to a Trimble instrument, depending on where the software is in the auto-connect cycle when the instrument is connected.

Trimble instruments that can be automatically connected to are organized into the following groups:

- Trimble GNSS receivers
- Trimble VX Spatial Station or Trimble S Series total station
- Trimble 5600/3600 total stations

If you connect to only one of these types of instrument, you can speed up the automatic connection time by clearing the check box for the instrument type(s) you do not connect to.

If the [PIN function is enabled](#), the *Unlock instrument* screen appears when connecting to a Trimble VX Spatial Station or Trimble S Series total station. Enter the PIN and then tap *Accept*.

If you are running the Trimble Access software on a supported third-party Windows computer, and you want to connect to that computer's internal GPS receiver, select the appropriate COM port in the *Internal GPS* field.

To set the auto-connect options, tap the auto-connect icon in the status bar **before** you connect to an instrument.

You can also configure auto-connect from Settings. Tap *Settings* from the Trimble Access menu and then select *Connect / Auto connect*.

When the software is trying to automatically connect to an instrument, the auto-connect icon flashes. There is a different icon for each type of instrument. For example, if you select only *Trimble GNSS receivers*, then only a Trimble GNSS receiver icon flashes.

The software will only attempt to auto-connect to the currently configured receiver for the current mode: *Rover mode* or *Base mode* (see [GNSS functions](#)).

- If the software is in *Rover mode*, it will attempt to connect to the receiver configured in the *Connect to GNSS rover* field in the *Bluetooth settings* screen.
- If the software is in *Base mode*, it will attempt to connect to the receiver configured in the *Connect to GNSS base* field in the *Bluetooth settings* screen.
- If there is no receiver configured in the appropriate field in *Bluetooth settings*, then the software will attempt to auto-connect to a Trimble GNSS receiver on the serial port of the controller; and if a receiver is detected it will be treated as the receiver you wish to use in the current mode.
- The flashing icon, or the yellow highlight on the *GNSS Functions* screen, shows the mode which the software is currently in.

From the Auto connect *Options* screen, tap the required connection method button to go to the appropriate settings screen. You can also configure wireless connections from *Settings*. From the Trimble Access menu tap *Settings* and then select *Connect* and then select the connection method. Depending on the connected instrument, available connection methods are [Bluetooth](#) or [Radio](#).

If the auto connect icon displays multiple icons and a red x , then auto connect has been disabled for all four groups of instruments.

When you use *Instrument functions* to disconnect from the total station, auto-connect is temporarily disabled. To re-enable auto connect, tap the auto connect icon.

Note - When auto connect has been temporarily disabled, a single tap re-enables auto connect, and a second tap is required to display the Auto connect options screen.

You do not have to wait for auto connect to connect to your instrument. To force a connection, select the survey style and start the survey at any time.

To connect to a non-Trimble instrument, you must force a connection by starting the survey.

Tip - When using non-Trimble instruments, disable auto connect. Some commands used by auto connect can interfere with the communication of non-Trimble instruments.

Measure codes

To measure and code conventional or GNSS observations in one step, select the feature code you want to measure and store from a coding form containing a number of configurable buttons. You can define multiple groups or pages of codes, each consisting of up to 25 codes.

In the *Measure codes* form, if you activate the *Code* button, it affects the behavior of the configurable code buttons. When you then tap one of the configurable code buttons, the code on that button is added to the code field at the bottom of the *Measure codes* form. Typically, you can use the *Code* button to combine codes from multiple code buttons where features combine, either from the current group, or a combination of groups. You can also use it to enter a new code.

If a code has attributes, the attribute values appear at the bottom of the *Measure codes* form. You cannot directly edit these attribute values in the form. To change the attribute values, do one of the following:

- Tap *Attrib* in the *Measure codes* form.
- Tap *Attrib* in the *Measure topo/Measure points* form.

For more information, see [Using feature codes with predefined attributes](#).

Adding a feature code group and assigning codes to the buttons

1. Select *Measure / Measure codes* and then tap *Add group*.
2. Enter a *Group name* and then tap *OK*.
3. To configure the number of code buttons that appear in each group, tap *Options* and then select the appropriate setting in the *Code button layout* field.

Notes

- To be able to activate the code button using the numeric keys on the controller keyboard, you must select *3x3* in the *Code button layout* field.
- The list of codes for each group is independent. For example, if you create codes for buttons using a *3x3* layout and then change the layout to *3x4*, then three additional

empty buttons are added to the group. The software does not move the first three buttons from the subsequent group into the current group.

- *The codes defined for a group are remembered, even if they are not displayed. For example, if you create codes for buttons using a 3x4 layout and then change the layout to 3x3, only the first nine codes are displayed. If you change the layout back to 3x4, all twelve codes are displayed.*

4. To add a code to a button:

- Tap and hold on the button. When the tooltip message appears, remove the stylus from the screen. In the dialog that appears, enter the code, or select a code from the feature code library.
- Navigate to the button using the arrow keys, and then press the Space key, which emulates the 'tap and hold' action.

In the dialog that appears, enter the code, or select a code from the feature code library. Tap **OK**. The code you entered now appears on the button.

If required, you can also enter additional [descriptions](#).

5. To add another code, or remove a code from a button, repeat Step 3.

6. To add more groups of feature code buttons, tap *Add group*.

To navigate to a particular group, select it from the drop down list in the top left of the form. Alternatively, use A - Z to quickly switch to group pages 1 - 26. This method is not available if the *Code* button is enabled.

New groups are added **after** the current group. To add a group to the end of existing groups, ensure you select the last group before selecting *Add group*.

Measuring and coding observations

1. Select *Measure / Measure codes*.

2. To initiate a measurement, activate the button using one of the following methods:

- Tap the button.
- Press the numeric key on the controller keyboard corresponding to the button. When the buttons are set to a 3x3 layout, keys 7, 8, 9, activate the top row of buttons, keys 4, 5, 6 activate the middle row of buttons, keys 1, 2, 3 activate the bottom row of buttons.
- Use the arrows keys on the controller to navigate to the button and then press **Enter**.
If the code has attributes, the attribute values appear at the bottom of the *Measure codes* form.

3. To automatically start the measurement when the button is selected, tap *Options* and then select the *Auto measure* check box.

Note - *When the method is set to Distance offset, Angles only, and H Angle only, Automeasure is temporarily paused.*

4. To configure the position of the highlight for the next code, tap *Options* and then configure the *Direction of the Template pickup*.

5. The code field is set to the code on the button and the measurement is initiated. The

measurement is automatically stored depending on the setting in *Options*:

- In a GNSS survey, set the Topo point options to *Auto store point*.
- In a Conventional survey, clear the *View before storage* check box in the *Measure point options* form.

If descriptions were defined on the Measure codes button, the descriptions are also set to the descriptions on the button.

6. Once you store the measurement, the *Measure codes* form appears, ready for the next measurement.

Tap [Enter] to measure a point with the same code again, or use one of the methods described in step 2 above to measure with a different code.

The *Measure topo/Measure points* form, where the measurement was initiated, remains open in the background. If you need to change the point name or measurement method, tap *Switch to* to switch to this form, change the fields as required and then tap *Switch to* again to return to the *Measure codes* form.

Notes

- *The first time that you use Measure codes, the measurement may not begin automatically if you have not defined the point name and target height. If this occurs, complete these fields and then tap Measure to begin the measurement.*
- *To change target or antenna heights, tap the target icon in the status bar.*
- *During a measurement, you can change the point name, and the target or antenna height and code. However, you can do this only if you start editing before the observation is stored. Alternatively, tap Esc as soon as the measurement begins, make the required changes, then tap Measure to restart the measurement.*
- *To change the EDM or measurement method, tap Esc during the measurement, make the required changes, then tap Measure to restart the measurement.*
- *To change the point name or measurement method before you start a measurement, tap Switch to to switch to the Measure topo/Measure points form, change the fields as required and then tap Switch to again to return to the Measure codes form.*
- *When using a GNSS receiver with an in-built tilt sensor where the point type has been configured to use [Tilt auto-measure](#), the point will not auto-measure until the pole is within the specified tilt tolerance.*
- *When using a GNSS receiver with an in-built tilt sensor, you can configure the survey style to prompt a warning when the pole is outside a specified [Tilt tolerance](#).*
- *Tap Options to configure the quality control, precision, and [tilt settings](#).*
- *To add a vertical offset to the measured point, tap Options, select Add vertical offset and then in the Measure points screen enter a value in the Vertical offset field. This option is available only for points measured in a GNSS survey.*

Creating a template of a measurement code sequence

Use the *Template pickup* feature to automatically move the highlight from the current button to the next button after storing a measurement. Template pickup is particularly useful when coding observations in a regular pattern, for example, a road cross section.

To configure template pickup, tap *Options* and then configure:

- The template pickup *Direction*. Refer to the following diagram:

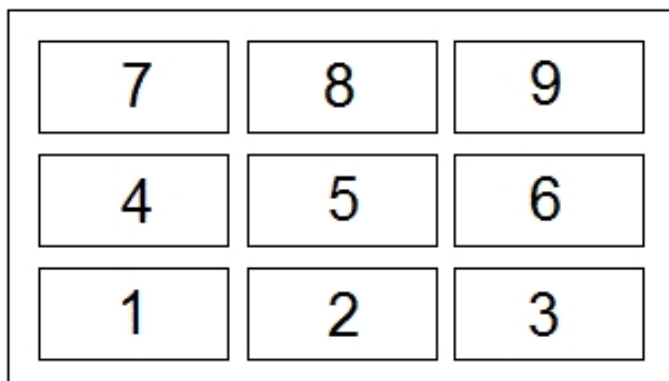

For:

- Left to right - The highlight moves from 7-9, then 4-6, then 1-3.
- Right to left - The highlight moves from 3-1, then 6-4, then 9-7.
- Zig zag - The highlight moves from 7-9, 4-6, 1-3 then 3-1, 6-4, 9-7, then 7-9 and so on.

If the *Direction* is set to *Off*, the highlight remains on the selected button after a measurement is taken.

To skip a code, tap a different button, or use the arrow keys to select an alternative code button.

- The *Number of elements*:
 - The *Number of elements* configured should match the number of elements across the template, and the number of buttons configured in Measure codes.

Notes

- When the code button layout is 3x3 the numeric keypad on the controller can be used as a keyboard shortcut for the buttons in Measure codes.
- To measure a point with a null code, activate a blank code button. Alternatively, tap Code, ensure that the code field is empty and then tap Measure.
- To store a *note* with an observation, tap .
- To delete an entire group of codes, select the group and then tap Delete.

Creating a template when you have multiple groups of codes

You can have up to 75 elements in a template. When there are more elements in a template than buttons in a group:

- Two or more groups are 'grouped' together with the highlight automatically moving between groups during template pickup.
- You can only configure the template pickup from Options on the first group. The second and third groups indicate that the template pickup was defined by the previous group.

- The up and down arrow on the keyboard moves through the current group only, but the left and right arrow on the keyboard can be used to move from the first/last button in one group to a button in the next group.
- New groups are added **after** the current group. To add a group to the end of existing groups, ensure you select the last group before selecting *Add group*.

Stringing support

Measure codes has '+' and '-' softkeys that enable you to apply a suffix to the code on the button. This is useful when you use the stringing method for feature coding.

You can configure the suffix to 1, 01, 001, or 0001.

When the suffix is configured to 01, tap '+' to increase the code "Fence" to "Fence01". Tap '-' to decrease the code by 01.

Tap *Find* to find the next available string for the currently highlighted button.

Attributes and base codes

You can configure the General Survey software to provide attributes for the complete code, or from a portion of the code - the "base code". See [Additional settings](#).

The following rules help to explain the base code:

1. When *Use attributes of base code* is disabled, the code displayed on a button is the base code.
 - Enter "Fence", string the code to become "Fence01", the attributes are derived from "Fence01".
2. When *Use attributes of base code* is enabled, the code entered on a button is the base code.
 - Enter "Fence", string the code to become "Fence01", the attributes are derived from "Fence".
3. If you edit or change the code on a button, the base code resets, using rule 1 or rule 2 above.
4. If you change the configuration of the *Use attributes of base code* setting, the base code resets, using rule 1 or rule 2 above.
5. When Measure codes passes the code to the Measure topo, or Measure points system, the base code from within Measure codes is retained.

Notes

- *If you use attributes and numeric codes with a string suffix, you must use Measure codes to define the suffix and start the measurement. Measure codes understands where the code ends and the suffix starts. If you do not use Measure codes, the entire numeric code + suffix will be treated as the code, the suffix cannot be determined, and attributes for the base code will not be available.*
- *To configure Use attributes of base code, from within Measure codes, use the up arrow softkey to select Options, and then select the check box as required.*
- *If the Use attributes of base code check box is selected, it is applied throughout the General Survey software.*

- *If you edit the code on a button when Use attributes of base code is disabled, the entire code from the code button is displayed in the Edit field.*
- *If you edit the code on a button when Use attributes of base code is enabled, the base code is displayed in the Edit field.*
 - *The code on the button is "Fence01" and the base code is "Fence". If you edit this code, the base code "Fence" is displayed.*
- *You can string alphanumeric codes when Use attributes of base code is disabled. The code displayed on the button is the base code.*
- *You cannot string numeric only codes when Use attributes of base code disabled.*

Tip - If you use multiple codes with attributes, enter all the codes **before** you enter the attributes.

Sharing groups of codes between controllers

The groups, and the codes within each group, are stored in a Measure Codes Database file (*.mcd). If you use a feature library, the Measure Codes Database file (*.mcd) is tied to that feature library and has a matching name. If you use the same feature library on other controllers, you can copy the *.mcd file to use in the other controllers. To use the feature library *.mcd file, you must assign the feature library to the job.

If you do not use a feature library, a [Default.mcd] file is created. The [Default.mcd] file can also be copied to other controllers. When the General Survey software does not have a feature library assigned to a job, the [Default.mcd] file is used in *Measure codes*.

Conventional Survey – Setup

Conventional survey – Getting started

The process for completing measurements using a conventional instrument is described below. Click each link to view more information.

1. [Configure your survey style if required](#)
2. [Prepare for a robotic survey](#)
3. [Perform a station setup](#)
4. [Begin the survey](#)
5. [Measure points](#)
6. [End the survey](#)

Configuring conventional survey styles

All surveys in General Survey are controlled by a **survey style**. Survey styles define the parameters for configuring and communicating with your instruments, and for measuring and storing points. This whole set of information is stored as a template and used each time you start a survey.

General Survey automatically connects to Trimble instruments. Configure the style only if the defaults do not suit your needs.

To configure a survey style:

1. From the Trimble Access menu, tap *Settings / Survey styles / <Style name>*.
2. Select each of the options in turn, and set them to suit your equipment and survey preferences.
3. Once you configure all the settings, tap *Store* to save them, and then tap *Esc* to return to the main menu.

For more information, see:

[Conventional instrument configuration](#)

[Topo point](#)

[Stakeout options](#)

[Laser rangefinder](#)

[Duplicate point tolerance](#)

Traverse options

Conventional instrument configuration

Configure the conventional instrument type when you create or edit a survey style. Select *Instrument*, choose the [instrument type](#), and then set the associated parameters.

Bluetooth wireless connection

To connect to the instrument using Bluetooth wireless technology, see [Enabling Bluetooth on the device](#).

Baud rate and parity

Use the *Baud rate* field to configure the General Survey baud rate to match that of the conventional instrument.

Use the *Parity* field to configure the General Survey parity to match that of the conventional instrument.

When you change the instrument type, the baud rate and parity settings automatically change to the default settings for the selected instrument.

HA VA status rate

Use the *HA VA status rate* field to set how often the General Survey software updates the horizontal and vertical angle display in the status line with information from the conventional instrument.

Note - Some instruments beep when communicating with the General Survey software. You can turn off the beep in the instrument or set the HA VA status rate to Never.

Measurement mode

The *Measurement mode* field appears if the selected instrument type has more than one measurement mode that can be set by General Survey. Use this mode to specify how the EDM measures distances. Options vary according to the instrument type. Select the *Instr. default* option to always use the setting on the instrument.

Tip - Tap Instrument functions to quickly change the measurement mode when using Trimble instruments and some Leica TPS instruments.

Trimble terminology matches the measurement modes on the Leica TPS1100 instruments as follows:

Trimble terminology	Leica terminology
STD	Standard
FSTD	Fast
TRK	Rapid tracking
DR	Reflectorless

Averaged observations

Use the Averaged observations method to:

- increase the measurement precision with a predefined number of observations
- view the associated measurement standard deviations

While the instrument is carrying out the measurements, standard deviations are displayed for the horizontal (HA) and vertical (VA) angles, and the slope distance (SD).

Auto F1 / F2

When using a servo or robotic instrument, select the *Auto F1 / F2* check box to automatically measure a point or stakeout a position on face 2 after the face 1 observation.

Note - *The Auto F1 / F2 functionality is not suitable for use when staking with a 5600 instrument using Autolock as it is not able to operate the EDM in tracking mode on face 2.*

When *Auto F1 / F2* is selected, once the face 1 measurement is completed, the instrument automatically turns to face 2. The point name does not increment, which allows a face 2 observation to be measured with the same point name as the face 1 observation. Once the face 2 measurement is completed, the instrument returns to face 1.

Auto F1 / F2 does not work when starting on face 2, or when the measurement method is set to:

- Angle offset
- H. Angle offset
- V. Angle offset
- Single dist. offset
- Dual-prism offset
- Circular object
- Remote object

Measure distance on face 2

The *Measure distance on face 2* option is used in:

- Measure topo, when *Auto F1 / F2* is selected
- Measure rounds, Station setup plus, and Resection, when a distance observation is not required on face 2

When the *Measure distance on face 2* option is selected, if the face 1 measurement method included a distance measurement, then the measurement method for face 2 is automatically set to *Angles only* after the face 1 measurement. After the face 2 measurement, the instrument returns to the method used on face 1.

Set backsight

The *Set backsight* field appears if you can set the horizontal circle reading on the instrument when the backsight is observed. The options are *No*, *Zero*, and *Azimuth*. If you select the *Azimuth* option, when you observe the backsight the horizontal circle reading is set to the computed azimuth between the instrument point and the backsight point.

Servo auto turn

When using a servo instrument, the *Servo auto turn* field in the survey style can be set to *HA & VA*, *HA only*, or *Off*. If you select *HA & VA*, or *HA only*, the instrument automatically turns to the point during stakeout, and when a known point is entered into a point name field.

If you are working robotically, or when the *Servo auto turn* field in the survey style is set to *Off*, the instrument does not turn automatically. To turn the instrument to the angle indicated on the screen, tap *Turn*.

Instrument precision

Instrument precisions are used to compute the observation weights as part of the Standard resection and Station Setup Plus computations.

When you use a Trimble total station, the instrument precisions are read from the instrument. You can either use the precisions from the instrument, or provide your own values based on your observing techniques by selecting the *Edit instrument precisions* check box. For other types of instrument do one of the following:

- Enter the values provided by the instrument manufacturer
- Leave the instrument precision value fields as null

If you leave the instrument precision value fields as null, the following default values are used:

Observation	Default value
Horizontal angle precision	1"
Vertical angle precision	1"
EDM	3 mm
EDM (ppm)	2 ppm

Centering error

A centering error can be specified for the instrument and backsight.

The centering error is used to compute the observation weights as part of the Standard resection and Station Setup Plus computations. Set a value appropriate to the estimated accuracy of your instrument/backsight setup.

Conventional instrument type

In a conventional survey style, you need to specify the type of instrument being used.

Choose a model made by one of the following manufacturers:

- Trimble
- Leica
- Nikon
- Pentax
- Sokkia

- Spectra Precision
- Topcon
- Zeiss

Choose *Manual* when you want to key in the measurements.

Choose one of the following SET types:

- SET (Basic), when using a Nikon instrument (if your instrument does not support a Nikon survey style). Make sure that the units on the instrument are the same as the units in General Survey.
- SET (Extended), when using any Sokkia instrument.

Tip - When using non-Trimble instruments, disable auto-connect. Some commands used by auto-connect can interfere with the communication of non-Trimble instruments.

Tip - Set the baud rate to 38400 to connect to the Nikon NPL-352 (or similar models).

Creating a survey style for the Leica TPS1100 and TPS1200 instruments for a servo or robotic survey

The survey style configuration for a Leica TPS1100 and for a TPS1200 instrument are very similar except for the baud rates.

To create a survey style for a Leica 1100/1200 instrument:

1. From the Trimble Access menu, tap *Settings / Survey styles*.
2. Tap *New*.
3. Enter a name in the *Style name* field.
4. In the *Style type* field, select *Conventional* and then tap *Accept*.
5. Tap *Instrument*.
6. In the *Manufacturer* field, select *Leica*.
7. In the *Model* field, select either *TC1100 Servo (GeoCom)* or *TC1100 Robotic (GeoCom)*, depending on whether you will perform a servo or a robotic survey.
8. Set the *Baud rate* and *Parity* to match the settings on the instrument.
 - For the TPS1100 instrument, use a *Baud rate* of **19200** and *Parity* of *None*.
 - For the TPS1200 instrument, use a *Baud rate* of **115200** and *Parity* of *None*.

Trimble recommends an *HA VA status rate* of 2 seconds or slower. Faster rates can interfere with communication to the instrument.

For more information on *Send record acknowledgement*, see below.

Most of the other settings depend on how you want to use the software - configure them as required.

9. Tap *Accept* and then tap *Store* to save the changes.

Configuring a Leica TPS1200 instrument for a servo or robotic survey

In both servo and robotic surveys, General Survey communicates with a Leica TPS1200 instrument using the RCS (Remote Control Surveying) communication protocol through the GeoCOM mode

interface.

To communicate with the TPS1200 instrument with a non-Leica controller, you must have the Leica GeoCOM Robotics License Key. You can make a connection to the instrument without the key, but many functions such as Lock, Search, Change face, and Turn to point will not work.

To configure the instrument:

1. From the Main menu on the Leica TPS1200, press 5 [Config...] and then press 4 [Interfaces...].
2. Use the keyboard arrow key to highlight these three devices; [GSI Output], [RCS Mode], and [Export Job], one-by-one and then press F5 [USE] to clear the currently selected devices, if required.
3. Use the keyboard arrow key to highlight [GeoCOM Mode] and then press F5 [USE] to set a [Device]. You need to set the device to [TCPS27] and configure the port settings. The device currently displayed may not be [TCPS27] but you will configure that in the next step.
4. To set the correct [Device], press F3 [EDIT] and then press F5 [DEVCE]. Press F6 [PAGE] until the [Radios] tab is highlighted and then use the arrow key to highlight [TPCS27].
5. Press F3 [EDIT] to configure the comms settings for the [TCPS27], as follows:
 - [Baud Rate] = 115200
 - [Parity] = None
 - [Data Bits] = 8
 - [Stop Bits] = 1

These are the default settings used with Leica 1200 TCPS27 radios, and these parameters will be set in the base radio connected to the Leica 1200 instrument. Make sure that the rover radio is configured to the same parameters.

Also make sure that the rover radio is set up as a [Remote] radio, the base radio is set up as a [Base] radio, and that they are both on the same [Link] frequency. You are using default settings so these parameters are probably already configured correctly, but if you have communication problems between the radios, check these settings.

To test if the radios are communicating, you can use the Microsoft HyperTerminal application, with each radio connected to a computer.

For more information, refer to your Leica manual or contact your Leica reseller.

6. To save the correct comms settings, press F1 [STORE] and then press F1 [CONT] to continue. The [GeoCOM Mode] screen now shows:
 - [Use Interface] = [Yes]
 - [Port] = [Port 1]
 - [Device] = [TCPS27]
 - [Protocol] = [RS232 GeoCOM]
7. To exit from the main menu, press F1 [CONT] two times.

The instrument is now configured for communication through the TCPS27 radios.

Note - You can communicate with the TPS1200 instrument regardless of the current screen displayed on the instrument - provided that the comms settings on the instrument, the radios, and the General Survey software are correct. This is different from the TPS1100 instrument.

Configuring a Leica TPS1100 instrument for a servo or robotic survey

In both a servo and robotic survey, General Survey communicates with a Leica TPS1100 model instrument using the RCS (Remote Control Surveying) protocol.

To configure the instrument:

1. From the Main menu on the Leica TPS1100, press 5 [Configuration] and then press 2 [Communication mode].
2. Press 1 [GSI parameters] and then set the [Baudrate] to 19200, [Protocol] to None, [Parity] to None, [Terminator] to CR/LF, and [Data Bits] to 8.
3. Press [Cont] to continue.
4. Press 5 [RCS (Remote) On/Off]. Make sure that [Remote control mode] is **off**.
5. To put the instrument in the [Measure and Record] screen, press F1 [Back] twice and then press F6 [Meas].

Note - You do not need to configure 2 [GeoCOM parameters], 4 [RCS parameters], and you do not need to put the instrument in [GeoCOM On-Line mode] or switch on RCS mode.

Tip - General Survey can only communicate with the instrument when the instrument is in the [Measure and Record] screen. To configure the instrument to start in the [Measure and Record] screen, select 5, 1, 04 from the main menu on the Leica instrument. Set the [Autoexec] to [Measure and record].

The General Survey software does not support the use of [ATR] mode during automated rounds. The [ATR] state is not updated during the round. Use [Lock] rather than [ATR] mode during automated rounds.

Tip - To use the Reflectorless technology of your instrument, configure the instrument to reflectorless. In General Survey, set the *Measurement mode* to *Instr. Default*. Alternatively, tap the Target icon in the status bar and select *Target DR* to switch to *Target DR* and automatically configure the instrument for reflectorless (DR) mode.

Note - Search does not work when the instrument is in reflectorless (DR) mode.

Note - The Leica TC/TPS1100 survey styles have been designed to operate specifically with the TPS1100 instruments. However, the TC/TPS1100 style may also be used to operate other Leica TPS instruments, for example the Leica TPS1200, using the same protocol.

Configuring a Leica TPS1100 instrument to record data to the General Survey software

You can configure a Leica TPS1100 instrument to trigger a measurement and then record the data to the General Survey software.

Note - Record mode is supported in the General Survey software only when using Measure topo.

To enable this function on the Leica instrument, you must [configure the format of the data](#) and then [configure where to send the data](#).

Configuring the format of the data

To configure the Rec-Mask so that the correct information is sent to the General Survey software:

1. From the Main menu on the Leica TPS1100, press 5 [Configuration] and then press 1 [Instrument config].
2. Press 05 [Display and Record].
3. Press F4 [RMask].
4. In the [Define] field, select an appropriate [Rec-Mask] to configure.
5. Set the [Mask name] to something appropriate.
6. Set the [REC format] to [GSI16 (16 char)].
7. The [1st word] is set to [Point Id (11)]. You can not change this.
8. Set the [2nd word] to [Hz (21)].
9. Set the [3rd word] to [V (22)].
10. Set the [4th word] to [Slope Dist (31)].
11. Set the [5th word] to [/ (empty)].
12. Set the [6th word] to [Point Code (71)]. This step is optional.

When a point code is output from the instrument, it replaces the code in the code field in the *Measure topo* form.

To enter a Point code on the Leica instrument, you may need to configure the [Display mask](#).

13. Press [CONT] to continue.

On the [Main Display and Record] form the [REC-Mask] now appears with the name you gave the recording mask in step 5 above.

14. To return to the Main menu, press [CONT] / [BACK] / [BACK].

Configuring where to send the data

To configure the instrument to send the REC-Mask data to the RS232 port:

1. From the Main menu on the Leica TPS1100, press F5 [SETUP].
2. Set the [Meas job] field to [RS232 RS].

The [REC-Mask] field appears with the name you gave the recording mask in step 5 above.

3. To return to the [Measure & Record] screen, ready to start measuring points, press F6 [MEAS].

The Leica TPS1100 instrument is now configured to measure and send the point name, code, and measurement details to the General Survey *Measure topo* screen when you use F1 [All] on the Leica TPS1100 instrument.

Measure topo is the only place in the General Survey software where you can trigger a measurement on the Leica instruments and have the data stored to the controller.

Depending on the model (and possibly the firmware) of your instrument, you may need to configure the General Survey software. Some models require an acknowledgement from the controller that they have received the data.

If the instrument reports a comms error [Comm. error : wrong response.], and fails to increment the point name on the instrument, then you need to send an acknowledgment to the instrument.

To send an acknowledgement, select the *Send record acknowledgement* option in the Leica style, or in *Measure topo / Options*.

Note - If you selected the *Send record acknowledgement* check box, the status line in the General Survey software is disabled and the target icon is not updated with Lock status information from the instrument. View the Lock status through the instrument panel.

In the General Survey software, configure the *View before storage* field as required:

- When *View before storage* is on, the measurement details appear, and you can change the code field before storing the observation.
- When *View before storage* off, the measurement details appear briefly on the large button before the observation is stored.

Notes

- Records, 11, 21, 22, 31, and 71 (as described above) are the only records read by the General Survey software. All other records are ignored.
- The code field in the Leica software annotated [Point code] can be sent to the General Survey software.
- The code field in the Leica software annotated [Code] cannot be sent to the General Survey software.
- The point name must be defined in the Leica software and will always replace the point name in the Measure topo form. If *View before storage* is on, you do get the opportunity to change the point name.
- If the [Point code] has been defined in the Leica software it will always replace the Code in the Measure topo form.
- If the [Point code] is null in the Leica software it does not replace the code on the Measure topo form.
- If *View before storage* is on in the General Survey software, you can change the code before the observation is stored.
- When using Auto F1/F2 the General Survey software does not increment the point name for the face 2 observation. This feature does not work if the point names are sent from the Leica instrument. For Auto F1/F2 to work you must set the correct point names in the Leica instrument.

Configuring the display mask

To configure the Display mask so that the [Point code] field is available on the instrument:

1. From the Main menu on the Leica TPS1100, press 5 [Configuration] and then press 1 [Instrument config].
2. Press 05 [Display and Record].
3. Press F3 [DMask].
4. In the [Define] field, select an appropriate [Displ.Mask] to configure.
5. Set the [Mask name] to something appropriate.
6. Set the [word] corresponding to the position that you want the point code field displayed to [Point code].
7. Set the other [word] values as required.

8. Press [CONT] to continue.

On the [Main Display and Record] form the [Displ.Mask] now appears with the name you gave the display mask in step 5 above.

9. To return to the Main menu, press [CONT] / [BACK] / [BACK].

Configure topo point settings

A topo point is a previously configured method of measuring and storing a point. Configure this type of point when you create or edit a survey style.

To configure the survey style, from the Trimble Access menu, tap *Settings / Survey styles / Topo point*.

Use the *Measure display* field to configure how the observations are displayed on the controller.

Use the *Auto point step size* field to set the increment size for automatic point numbering. The default is 1, but you can use larger step sizes and negative steps.

Select the *View before storage* check box to view observations before they are stored.

Preparing for a robotic survey

To prepare a Trimble servo total station for a robotic survey, the instrument must be turned on, leveled, with the correct radio settings, and if required, a search window defined.

If the instrument is level, has the correct radio settings, and you are using the autocentered search window, press the trigger button to turn on the instrument for a robotic survey.

To configure the Radio channel and Network ID on a Trimble servo total station without using the General Survey software, select [Radio settings] on the instrument through the *Face 2* menu display. For more information, refer to the documentation for your instrument.

Note - *The internal radio settings are set when the General Survey software connects to the instrument. The remote radio settings are set later when you start the rover survey.*

Note - *General Survey cannot communicate with the Trimble servo total station when the onboard programs are in use. Once you finish using the instrument's onboard programs, select [Exit] from the [Setup] menu to return to the [Waiting for connection] menu.*

When the instrument is suspended ready for robotic operation, it switches off to conserve power. The internal radio remains switched on so that the rover radio can communicate with the instrument when you start the rover survey.

For more information, see [Radio settings](#).

Preparing the total station for a robotic survey

1. Connect the controller to the Trimble robotic total station using a cable or Bluetooth wireless technology.

If you are using a Trimble CU controller, attach the controller to the total station and then press the trigger button to turn on the instrument and controller.

2. Start the General Survey software, level the instrument and then tap *Accept* in the leveling screen. Tap *Esc* to exit the *Corrections* screen and the *Survey Basic* screen if they appear.
3. From the Trimble Access menu, tap *Settings / Connect / Radio settings*.
4. Set the *Radio channel* and *Network ID* and then tap *Accept*. If you are using an external radio, you must reconfigure the radio port setting on the controller (see [Using a controller with an external radio](#)).
5. Do one of the following:
 - If you plan to use an [autocentered search window](#), suspend the controller by pressing the Power key. You do not need to define the search window now.
 - To set a search window:
 - a. From the main menu, select *Measure / Start robotic*.
 - b. Select *Define now* and tap *Accept*.
 - c. Aim the instrument to the top left corner of the search window and tap *OK*.
 - d. Aim the instrument to the bottom right corner of the search window and tap *OK*.
 - e. When prompted, disconnect the controller from the instrument and tap *OK*.
If you are using a Trimble CU controller, remove the controller from the instrument and attach it to the robotic holder.

The General Survey software auto-connects to the instrument radio. You are now ready to perform a station setup.

Preparing the total station for a robotic survey using a CU controller

The following section describes how to level the instrument, configure the radio settings, and set the search window on the instrument through the Trimble CU controller.

1. With the Trimble CU attached to the Trimble VX Spatial Station or Trimble S Series total station, press the trigger button to turn on the instrument and controller.
2. Start the General Survey software, level the instrument and then tap *Accept* in the leveling screen. Tap *Esc* to exit the *Corrections* screen and the *Survey Basic* screen if they appear.
3. From the Trimble Access menu, tap *Settings / Connect / Radio settings*.
4. Set the *Radio channel* and *Network ID* and then tap *Accept*.
5. Do one of the following:
 - To set a search window:
 - a. From the main menu, select *Measure / Start robotic*.
 - b. Select *Define now* and tap *OK*.
 - c. Aim the instrument to the top left corner of the search window and tap *OK*.
 - d. Aim the instrument to the bottom right corner of the search window and tap *OK*.
 - e. Tap *OK* to suspend the controller ready for robotic operation.
 - If you plan to use an [autocentered search window](#), press the power key on the Trimble CU to suspend the controller. You do not need to define the search window now.
6. Remove the controller from the instrument and attach it to the robotic holder.

7. Press the power key on the Trimble CU. The General Survey software auto-connects to the instrument radio and displays the leveling screen. If required, level the instrument and tap *Accept*.

You are now ready to perform a station setup.

Preparing the Trimble 5600 instrument for a robotic survey

1. With the Trimble CU attached to the Trimble 5600 instrument, press the trigger button to turn on the instrument and controller.
2. Start the General Survey software, level the instrument and then tap *Accept* in the leveling screen. Tap *Esc* to exit the *Corrections* screen and the *Survey Basic* screen if they appear.
3. From the Trimble Access menu, tap *Settings / Connect / Radio settings*.
4. Set the *Radio channel*, *Station address* and *Remote address* and then tap *Accept*.
5. Do one of the following:
 - To set a search window:
 - a. From the main menu, select *Measure / Start robotic*.
 - b. Aim the instrument to the top left corner of the search window and tap *OK*.
 - c. Aim the instrument to the bottom right corner of the search window and tap *OK*.
 - d. Tap *OK* to suspend the controller ready for robotic operation.
 - If you plan to use an [autocentered search window](#), press the power key on the Trimble CU to suspend the controller. You do not need to define the search window now.
6. Remove the controller from the instrument and then attach the controller to the robotic holder:
 - a. Connect the Trimble CU to Port A on the remote radio using the Trimble CU holder or a 0.4 m, 4-pin Hirose cable.
 - b. Turn on the active target or connect it to Port B on the remote radio.
7. Press the power key on the Trimble CU. The General Survey software auto-connects to the instrument radio and displays the leveling screen. If required, level the instrument and then tap *Accept*.

You are now ready to perform a station setup.

Note - The 5600 is re-initialized to compensate for the earlier removal of the controller.

Station setups – Overview

In a conventional survey, you must complete a **station setup** to orientate the instrument.

Note - Before you can use the *Turn to* or *Joystick* functions to turn a servo or robotic instrument, you must have a current station setup.

Select the station setup appropriate to your requirements:

Select...	If...
Station setup	You want to perform a standard station setup or if you are performing a traverse type survey.
Station setup plus	You want to perform a station setup by making observations to more than one backsight point.
Resection	You do not know the coordinates for the instrument point, and you can determine the coordinates by making observations to known backsight points.
Refline	You want to establish the position of an occupied point relative to a baseline.
Use last	You are satisfied that the last completed station setup is still valid, and you wish to continue observing points from this station.

Once you have completed a station setup, the *Measure* menu provides a *New <station setup>* option. Select this option to perform the same type of station setup as the one previously completed, without first ending the survey. To perform a different type of setup you must first [end the survey](#).

Station coordinates and instrument height

For a 2D or planimetric survey, leave the instrument height field set to null (?). No elevations are calculated. Unless you are using a Scale only projection, a project height must be defined in the coordinate system definition. The General Survey software needs this information to reduce measured ground distances to ellipsoid distances and to compute 2D coordinates.

If the point is available from a linked file, select the linked file for the job and then enter the point name in the *Instrument point name* or *Backsight point name* field. The point is automatically copied to the job.

If you cannot determine the coordinates for the instrument point and/or backsight point, you can key them in or measure them later using GNSS (provided that there is a valid GNSS site calibration). The coordinates of any points measured from that station are then computed.

If you enter the instrument point later, make sure that you choose to overwrite the original instrument point in the *Duplicate point* form. The coordinates of any points measured from that station are then computed.

You can use the Point manager to edit the coordinates of the instrument point and/or backsight point. If you do, then the positions of all records that are computed from that station setup position may change.

When measuring to the bottom notch on a Trimble total station, tap  and then select *Bottom notch*. Enter the height measured to the top ridge of the bottom notch on the instrument. General Survey corrects this measured slope value to true vertical and adds the offset (*Ho*) to calculate true vertical to the trunnion axis.

Note - If you select *Bottom notch*, the minimum slope distance (*Hm*) that you can enter is 0.300 meters. This is approximately the minimum slope distance that can be physically measured. If this minimum is too low, you must measure to the top mark.

For details, see the following figure and tables.

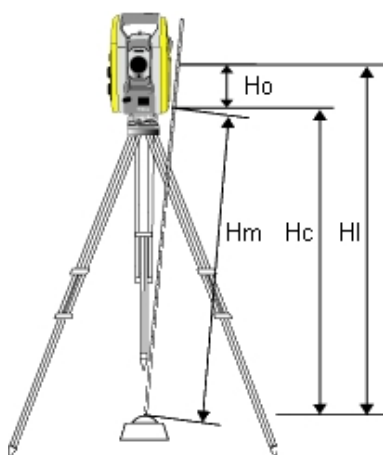

Value	Definition
H_o	Offset from bottom notch to trunnion axis. The value of the offset depends on the connected instrument. Refer to the following table.
H_m	Measured slope distance.
H_c	H_m corrected from slope to true vertical.
H_l	$H_c + H_o$. True vertical instrument height.

Connected instrument	Offset value
Trimble VX Spatial Station or Trimble S Series total station	0.158m (0.518 sft)
Trimble S Series traverse prism	0.158m (0.518 sft)

Loading station data to a Trimble 5600 and ATS instrument

When you complete a station setup with a Trimble 5600 or ATS instrument, the General Survey software loads the station information into the instrument.

Note -

- The instrument does not accept a null instrument height. If the instrument height is set to null in the General Survey software, then the software writes 0 to label V,50 and clears bit 1 in label PV,52.
- The instrument does not accept a null H.Distance. If the General Survey software cannot compute an H.Distance between the instrument and the backsight point (that is, Keyed in azimuth, Angles only, or H.Angle only backsight observation) then the software writes 0 to label PV,51.

Station setup

Select *Station setup* to perform a standard station setup to one backsight, or if you are performing a traverse type survey. If you want to measure more than one backsight point, use [Station setup plus](#).

Station setup options

Tap *Options* to configure *Station setup* to match the way that you prefer to work.

You can configure the default point names, default heights, default instrument coordinates, and the default azimuth. Default instrument coordinates and default azimuth are used only if the instrument point is not already coordinated, and an azimuth to the backsight cannot be computed.

Default point names

The *Default point names* option determines the default values for the instrument and the backsight point name fields each time you perform a station setup:

- If you always use the same names for your instrument and backsight points, select *Last used*. Use this method if you always use the default instrument coordinates, or if you repeatedly set up on the same known point.
- If you are performing a traverse type survey, select *Traversing*. When you start a new station setup, by default, the instrument uses the first foresight point observed from the last station setup for the *Instrument point name*, and the instrument point name used in the last station setup for the *Backsight point name*.
- If you want to key in or select the instrument and backsight point names each time you perform a station setup, select *All null*.
- To automatically increment the instrument point name, select *Auto increment*.

Note

- *These are only default values. You should select the option that matches your normal workflow. You can override the default values for any particular station setup.*
- *If you always set up your instrument on a known point, and use a known azimuth, then leave the Default instrument coordinates and Default azimuth fields set to null. This ensures that you do not accidentally use default values if you incorrectly enter the name of the instrument and/or the backsight point names.*
- *Do not confuse the Last used option with the Use last survey menu option. The Last used option applies to a new station setup. The last values are used even across different jobs. The Use last menu option reinstates the last station setup. No new station setup is performed.*

Default heights

The *Default heights* option determines the default values for the instrument and the backsight point height fields each time you perform a station setup.

- If you always use the same heights for your instrument and backsight points, select *Last used*. This option is available only if you set the *Default point names* option to *Last used*.
- If you are using the Trimble traverse kit (so that the last measured foresight and instrument heights can be used as the new instrument and backsight heights), select *Move forward*. This option is available only if you set the *Default point names* option to *Traversing*.
- If you want to key in a new instrument and backsight height for each station setup, select *All null*.

Default instrument coordinates

If the instrument point does not exist, the default instrument coordinates are used. This is particularly useful if you work in a local coordinate system, and always set up your instrument on coordinate (0,0,0) or (1000N, 2000E, 100E), for example. If you leave the *Default instrument coordinates* set to null, you can key in coordinates for instrument points that do not exist when you perform a station setup.

Note - If you always set up your instrument on a known point then leave the *Default instrument coordinates* field set to null. This ensures that you do not accidentally use the default value if you incorrectly enter the name of the instrument point name.

Default azimuth

You can set a *Default azimuth*. This value is used only if an azimuth cannot be computed between the instrument and backsight points.

Performing a standard station setup

1. From the main menu, select *Measure / <Style name> / Station setup*.

Note - If you have only one style, it is automatically selected.

2. Set the [corrections](#) associated with the instrument.

If the *Corrections* form does not appear, tap *Options* from the *Station setup* screen to set the corrections. To make the *Corrections* form appear on startup, select the *Show corrections on startup* option.

For some instruments, the General Survey software automatically checks to see if various corrections (PPM, prism constant, and curvature and refraction) are being applied correctly. When you select *Station setup*, messages showing what has or has not been checked are displayed in the status line. If the General Survey software finds that the corrections are being applied twice, a warning message appears. When using the 5600 3600 instrument style, all corrections are applied in General Survey.

Note - When using a non-Trimble instrument, you must select the correct survey style **before** you connect the controller to the instrument. Otherwise, the instrument and controller may fail to connect.

3. Enter the instrument point name and the instrument height. If the point is not already in the database, you can key it in or leave it as null.

When measuring to the bottom notch on a Trimble total station, tap  and then select *Bottom notch*. Enter the height measured to the top ridge of the bottom notch on the instrument. General Survey corrects this measured slope value to true vertical and adds the offset (*Ho*) to calculate true vertical to the trunnion axis. For details, see figure and tables in [Station setups – Overview](#).

4. Enter the backsight point name and the target height. If there are no coordinates for the point, you can key in an azimuth.

When measuring to the bottom notch on a [Trimble prism base](#), tap  and then select *Bottom notch*. For details, see figure and tables in [Station setups – Overview](#).

Note - If you do not know the azimuth, you can enter an arbitrary value and then edit the azimuth record later, in review.

5. Choose an option in the *Method* field. The options are:
 - Angles and distance - measure horizontal and vertical angles and slope distance
 - Averaged observations - measure horizontal and vertical angles and slope distance for a predefined number of observations
 - Angles only - measure horizontal and vertical angles
 - H. Angle only - measure horizontal angle only
 - Angle offset - measure the slope distance first, the instrument can then be repointed and then measure the horizontal and vertical angles
 - H. Angle offset - measure the vertical angle and slope distance first, the instrument can then be repointed and then measure the horizontal angle
 - V. Angle offset - measure the horizontal angle and slope distance first, the instrument can then be repointed and then measure the vertical angle
 - Distance offset - enter the left/right, in/out or V.Distance offset from the target to the object when a point is inaccessible and then measure horizontal and vertical angles and slope distance to the offset object

When you use an offset method, tap *Options* and then set the *Offset & Stakeout directions* perspective.

Tip - When using Autolock technology and measuring offset points, select the *Autolock off for offsets* check box. When enabled, Autolock technology is automatically disabled for the offset measurement and then re-enabled after the measurement.

6. Sight the center of the backsight target and then tap *Measure*.
Select the *View before storage* check box to view observations before they are stored.
7. If Auto F1/F2 is enabled:
 - a. Tap *Store* to store the F1 observation. The instrument changes face.
 - b. Sight the center of the backsight target and then tap *Measure*.
8. If the residuals for the station setup are acceptable, tap *Store*.

Tip - To change the display, tap the view display button on the left of the measurement information.

Note - The residuals are the differences between the known position and the observed position of the backsight point.

Station setup is complete.

For more information

[Prepare for a robotic survey](#)

[Station setups – Overview](#)

[Station setup plus](#)

[Resection](#)

Traverse

[Advanced geodetics support](#)

Station setup plus

In a conventional survey, use **station setup plus** to perform a station setup on a known point by making observations to one or more backsight points.

WARNING - If the station setup point is a traverse station that you plan to adjust, **do not** measure more than one backsight point. Clear the *Backsight* check box for any additional points so that they are measured as foresights.

For more details, see:

[Performing a station setup plus](#)

[Skipping observations](#)

[Station setup – Residuals screen](#)

[Point – Residuals screen](#)

[Point details screen](#)

[Station setup results screen](#)

Performing a station setup plus

1. From the main menu, select *Measure / <Style name> / Station setup plus*.
2. Set the [corrections](#) associated with the instrument.
If the *Corrections* form does not appear, tap *Options* and then select the *Show corrections on startup* check box.
3. Enter the instrument point name. If the point is not already in the database, key it in or leave it as null.
If the coordinates for the instrument point are not known, perform a [Resection](#) to known points. This will provide the coordinates.
4. If applicable, enter the instrument height and then tap *Accept*.
When measuring to the bottom notch on a Trimble total station, tap  and then select *Bottom notch*. Enter the height measured to the top ridge of the bottom notch on the instrument. General Survey corrects this measured slope value to true vertical and adds the offset (*Ho*) to calculate true vertical to the trunnion axis. For details, see figure and tables in [Station setups – Overview](#).
WARNING - Before you continue, tap *Options* and make sure that the *Face order* setting is correct. You cannot change this setting after you start measuring points.
5. Enter the first backsight point name and the target height, if applicable. If there are no coordinates for the point, you can key in an azimuth.

When measuring to the bottom notch on a [Trimble prism base](#), tap  and then select *Bottom notch*. For details, see figure and tables in [Station setups – Overview](#).

Note - To include foresight points during station setup plus, clear the *Backsight* check box. Foresight points do not contribute to the station setup result.

6. Choose an option in the *Method* field.
7. Sight the target and then tap *Measure*.

The *Station setup residuals* screen appears.

See the following sections for more information on what do next.

Tip - Select [Interrupted target measurement](#) if the measurement is likely to be interrupted, for example, when measuring in traffic.

Skipping observations

When using *Automate rounds* you can configure the software to automatically skip obstructed foresight targets.

If the instrument cannot measure the point and *Skip obstructed foresights* is **enabled**, it skips that point and moves onto the next point in the rounds list.

If the instrument cannot measure the point and *Skip obstructed foresights* is **disabled**, a message appears after 60 seconds to indicate that the prism is obstructed. The General Survey software continues to try to measure to the target until instructed to skip the point. To do this, tap *Ok* for the obstructed prism message, tap *Pause* and then tap *Skip*.

When the General Survey software reaches the end of a rounds list in which points have been skipped, the following message appears:

Observe skipped points?

Tap *Yes* to observe the points that were skipped during that round. The observations can be skipped again if required. Tap *No* to end the round.

If a point is skipped in one round, all subsequent rounds continue to prompt for observations to that point.

When one observation from a pair of face 1 and face 2 observations has been skipped, the unused observation is automatically deleted by the General Survey software. Deleted observations are stored in the General Survey database and can be undeleted. Undeleted observations can be processed in the office software, but are not automatically used to recompute Mean Turned Angle (MTA) records in the General Survey software.

Backsight observations cannot be skipped using the *Skip obstructed foresights* option.

Station setup – Residuals screen

The *Station setup residuals* screen lists the residuals for each point observed in the station setup.

Use the *Station setup residuals* screen to do the following:

- To observe more points, tap *+ Point*. In a conventional only survey, when one measurement is completed, the General Survey software can provide navigation information for further points, and a *Navigate* softkey is available. Tap *Navigate* to navigate to another point. If connected to

a GNSS / GPS receiver or using a Trimble controller with internal GPS, the General Survey software can provide navigation information for any point, and a *Navigate* softkey is available. Tap *Navigate* to navigate to another point.

- To view the Station setup results, tap *Results*.
- To store the station setup, tap *Results* and then tap *Store*.
- To view/edit the details of a point, highlight the point and then tap *Details*.
- To view/edit the residuals of each individual observation to a point, tap the point in the list once.
- To start measuring rounds of observations to the points, tap *End face*.

Tips

- To highlight an item in a list, tap and hold the item for at least half a second.
- To sort a column in ascending or descending order, tap the column header. Tap the *Point* column header to sort the point in ascending or descending observed order.
- To change the residual display view, select an option from the drop-down list in the *Residuals* screen.
- To navigate to a point, tap *+ Point* and then tap *Navigate*.

Notes

- *A residual is the difference between the known position and the observed position of the backsight point(s).*
- *A foresight point that does not yet exist in the database has null residuals in the Residuals form.*
- *You cannot add the same point to a station setup more than once. To take further measurements to points already measured, select End Face. For more information, see [Measuring rounds in station setup plus or resection](#).*

Point – Residuals screen

The *Point residuals* screen lists the residuals for each observation to a point in the station setup.

Use the *Point residuals* screen to do the following:

- To disable an observation, highlight it and then tap *Use*.
- To view the details of an observation, highlight it and then tap *Details*.
- To return to the *Station setup residuals* screen, tap *Back*.

Note - *If you have measured face 1 and face 2 observations to a point, turning off the observation for one face will also turn off the observation for the other face.*

WARNING - If you turn off some (but not all) of the observations to a backsight point, the solution for the resection will be biased. There will be a different number of observations to each backsight point.

Point details screen

Use the *Point details* screen to:

- view the mean observation for a point in the station setup
- change the target height and/or prism constant for all observations to a point

Station setup results screen

The *Station setup results* screen shows information about the station setup solution.

Use the *Station setup results* screen to:

- return to the *Station Setup Residuals* screen (tap *Esc*)
- store the station setup (tap *Store*)

Note - During a *Station setup plus*, nothing is stored in the job until you tap *Store* in the *Results* screen.

Station setup is complete.

For more information

[Prepare for a robotic survey](#)

[Station setups – Overview](#)

[Measuring rounds in station setup plus or resection](#)

[Advanced geodetics support](#)

[Resection](#)

[Traverse](#)

Measuring rounds in station setup plus or resection

This topic describes how to measure multiple sets (rounds) of observations during a *Station setup plus* or *Resection*.

A round can consist of either:

- a set of single face 1 observations
- a set of matched face 1 and face 2 observations

Using *Station setup plus* or *Resection*, measure the points that you want to include in the rounds. When the rounds list has been built, tap *End Face*.

General Survey software:

- Directs you to change face when required. With servo-driven instruments, this happens automatically.
- Defaults to the correct point details for each observed point.
- Displays the results. This allows you to delete bad data.

For more details, see:

[Building a rounds list](#)

[Measuring rounds of observations](#)

[Skipping observations](#)

[Residuals screen](#)

[Point – Residuals screen](#)

[Point details screen](#)

[Automated rounds](#)

Building a rounds list

The rounds list contains the points used in the rounds observations. As each point is added to a *Station setup plus* or *Resection*, General Survey software automatically builds this list. For more information, see [Station setup plus](#) or [Resection](#).

When the rounds list is complete, tap *End face*. General Survey software prompts you for the next point to be measured in the rounds of observations.

Notes

- *You can not edit the rounds list. Before you tap End face, be sure to observe all points to include in the rounds observations.*
- *The top of the Measure rounds screen shows which face the instrument is on, the number of the current round, and the total number of rounds to be measured (shown in brackets). For example, Face 1 (1/3) shows that the instrument is on face 1 of the first round of three.*
- *Within Station setup plus or Resection, the maximum number of points in a round is 25.*

Measuring rounds of observations

Once the rounds list has been built, tap *End face*. General Survey software enters the default point name and target information for the next point in the rounds. To measure a point, tap *Measure*. Repeat this until all observations in the round are completed.

When all observations are complete, General Survey software shows the [Residuals screen](#).

Notes

- *When using servo or robotic instruments, check that the instrument has sighted the target accurately. Manually adjust it if necessary. Some instruments can perform accurate sighting automatically. For information on the instrument specifications, refer to the instrument manufacturer's documentation.*
- *If you are using a servo or robotic instrument to measure a known (coordinated) point, tap Turn.*
Alternatively, with a servo instrument, set the Servo auto turn field in the survey style to HA & VA, or HA only to automatically turn the instrument to the point.
- *If you tap Esc in the Measure screen, the current round is discarded.*

Skipping observations

When using *Automate rounds* you can configure the software to automatically skip obstructed foresight targets.

If the instrument cannot measure the point and *Skip obstructed foresights* is **enabled**, it skips that point and moves onto the next point in the rounds list.

If the instrument cannot measure the point and *Skip obstructed foresights* is **disabled**, a message appears after 60 seconds to indicate that the prism is obstructed. The General Survey software continues to try to measure to the target until instructed to skip the point. To do this, tap *Ok* for the obstructed prism message, tap *Pause* and then tap *Skip*.

When the General Survey software reaches the end of a rounds list in which points have been skipped, the following message appears:

Observe skipped points?

Tap *Yes* to observe the points that were skipped during that round. The observations can be skipped again if required. Tap *No* to end the round.

If a point is skipped in one round, all subsequent rounds continue to prompt for observations to that point.

When one observation from a pair of face 1 and face 2 observations has been skipped, the unused observation is automatically deleted by the General Survey software. Deleted observations are stored in the General Survey database and can be undeleted. Undeleted observations can be processed in the office software, but are not automatically used to recompute Mean Turned Angle (MTA) records in the General Survey software.

Backsight observations cannot be skipped using the *Skip obstructed foresights* option.

Residuals screen

At the end of each round, the *Residuals* screen appears. For more information, see [Station setup plus](#) or [Resection](#).

After you measure rounds, *Std Dev* becomes available in the *Residuals* screen. To view the standard deviations of the observations for each point, tap *Std Dev*.

Notes

- To change the residual display view, use the drop-down list in the *Residuals* screen.
- During a station setup plus or resection, nothing is stored to the job until you tap *Close and Store* to complete the station setup.

Point – Residuals screen

The *Point - Residuals* screen shows the residuals for the individual observations to a particular point. For more information, see [Station setup plus](#) or [Resection](#).

Note - If you have measured both face 1 and face 2 observations to a point, when you turn off a face 1 observation, you also turn off the corresponding face 2 observation. Similarly, when you turn off a face 2 observation, you also turn off the corresponding face 1 observation.

Point details screen

The *Point details* screen shows the point name, code, backsight status, target height, prism constant, mean observation, and standard errors for the observed point. For more information, see [Station setup plus](#) or [Resection](#).

Automated rounds

The *Automate rounds* option is available for Trimble servo total stations. When you select *Automate rounds*, the instrument automatically completes all rounds after the rounds list has been built.

If you tap *+ Round* after the instrument has completed the required number of rounds, the instrument performs one more round of observations. If you want the instrument to perform more than one extra round, enter the total number of required rounds **before** you tap *+ Round*.

For example, to measure three rounds automatically, and then measure another three rounds:

1. Enter 3 in the *Number of rounds* field.
2. Once the instrument has measured 3 rounds, enter 6 in the *Number of rounds* field.
3. Tap *+ Round*. The instrument measures the second group of 3 rounds.

Note - *Targets observed without Autolock are automatically paused.*

Station elevation

In a conventional survey, use the station elevation function to determine the elevation of the instrument point by making observations to points with known elevations.

Note - *Use only points that can be viewed as grid coordinates. (The station elevation calculation is a grid calculation.)*

A station elevation needs at least one of the following:

- one angles and distance observation to a known point, or
- two angles only observations to different points

To perform a station elevation:

1. From the main menu, select *Measure* and then perform a station set up. See [Station setups – Overview](#).
2. Select *Measure / Station elevation*. The instrument point name and code appear. If you entered the instrument height during the station setup, that also appears. Otherwise, enter the instrument height now. Tap *Accept*.

When measuring to the bottom notch on a Trimble total station, tap  and then select *Bottom notch*. Enter the height measured to the top ridge of the bottom notch on the instrument. General Survey corrects this measured slope value to true vertical and adds the offset (*Ho*) to calculate true vertical to the trunnion axis. For details, see figure and tables in [Station setups – Overview](#).

3. Enter the point name, code, and target details for the point with the known elevation. Tap *Measure*. Once the measurement is stored, the *Point residuals* appear.

4. From the *Point residuals* screen, tap one of the following softkeys:
 - *+ Point*, to observe additional known points
 - *Details*, to view or edit point details
 - *Use*, to enable or disable a point
5. To view the station elevation result, tap *Results* in the *Point residuals* screen. To accept the result, tap *Store*.

Note - *The elevation determined through this station elevation method overwrites any existing elevation for the instrument point.*

Resection

In a conventional survey, the resection function is used to perform a station setup and determine coordinates for an unknown point by making observations to known backsight points. The General Survey software uses a least-squares algorithm to compute the resection.

Note - *To determine the elevation of a point with known 2D coordinates, perform a station elevation once you have completed a station setup.*

A resection needs at least one of the following:

- Two angles and distance observations to different backsight points
- Three angles-only observations to different backsight points
- One angles and distance observation to a close-by point and one angles-only observation to a backsight point. This is a special case called eccentric station setup.

WARNING - Do not compute a resection point using WGS84 control and then change the coordinate system or perform a site calibration. If you do, the resection point will be inconsistent with the new coordinate system.

For more details, see:

[Resection](#)

[Resection – Residuals screen](#)

[Point – Residuals screen](#)

[Point details screen](#)

[Resection results screen](#)

[Eccentric station setup](#)

Performing a resection

1. From the main menu, select *Measure / <Style name> / Resection*.

Note - *If you have only one style, it is automatically selected.*
2. Set the [corrections](#) associated with the instrument.

If the *Corrections* form does not appear, tap *Options* and then select the *Show corrections on startup* check box.

3. Enter an instrument point name and instrument height, if applicable.

Note - *Once the resection is started you cannot enter a different instrument height.*

When measuring to the bottom notch on a Trimble total station, tap  and then select *Bottom notch*. Enter the height measured to the top ridge of the bottom notch on the instrument. General Survey corrects this measured slope value to true vertical and adds the offset (*Ho*) to calculate true vertical to the trunnion axis. For details, see figure and tables in [Station setups – Overview](#).

4. Set the *Compute station elevation* check box and then tap *Accept*.

Note - *For a 2D or planimetric survey, clear the Compute station elevation check box. No elevations is calculated*

WARNING - Before you continue, tap *Options* and make sure that the *Face order* setting is correct. You cannot change this setting after you start measuring points.

5. Enter the first backsight point name and the target height, if applicable.

When measuring to the bottom notch on a [Trimble prism base](#), tap  and then select *Bottom notch*. For details, see figure and tables in [Station setups – Overview](#).

Note - *In a resection, you can only use backsight points that can be viewed as grid coordinates. This is because the resection calculation is a grid calculation.*

If you perform a resection or station setup plus while running an [integrated survey](#), you can measure backsight points with GNSS. To do this, tap the *Options* softkey and then select *Auto measure GNSS*. Enter an unknown point name in the point name field. The General Survey software prompts you to measure the point with GNSS using the specified point name. The *Measure* softkey shows both a prism and a GNSS symbol. The General Survey software first measures the point with GNSS and then measures with the conventional instrument.

Make sure that you have a site calibration loaded when combining conventional and GNSS measurements.

6. Choose an option in the *Method* field.
7. Sight the target and then tap *Measure*.
8. Measure further points.

Note - *To include foresight points during resection, clear the Backsight check box. Foresight points do not contribute to the resection result.*

In a conventional survey, when two measurements are completed, the General Survey software can provide navigation information for further points, and a *Navigate* softkey is available. Tap *Navigate* to navigate to another point.

If connected to a GNSS / GPS receiver or using a Trimble controller with internal GPS, the General Survey software can provide navigation information for any point, and a *Navigate* softkey is available. Tap *Navigate* to navigate to another point.

9. When there is enough data for the General Survey software to calculate a resected position, the *Resection residuals* screen appears.

Tip - Select [Interrupted target measurement](#) if the measurement is likely to be interrupted, for example, when measuring in traffic.

Resection – Residuals screen

The *Resection residuals* screen lists the residuals for each point observed in the resection.

Use the *Resection residuals* screen to do the following:

- To observe more points, tap *+ Point*.
- To view the resection results, tap *Close*.
- To store the resection, tap *Close* and then tap *Store*.
- To view/edit the details of a point, highlight the point and then tap *Details*.
- To view/edit the residuals of each individual observation to a point, tap the point in the list once.
- To start measuring rounds of observations to the points, tap *End face*.

Tips

- To highlight an item in a list, tap and hold the item for at least half a second.
- To sort a column in ascending or descending order, tap the column header. Tap the *Point* column header to sort the point in ascending or descending observed order.
- To change the residual display view, select an option from the drop-down list in the *Residuals* screen.

Notes

- *A residual is the difference between the known position and the observed position of the backsight point(s).*
- *A foresight point that does not yet exist in the database has null residuals in the Residuals form.*
- *You cannot add the same point to a resection more than once. To take further measurements to points already measured, select End Face. For more information, see [Measuring rounds in station setup plus or resection](#).*
- *Within Station setup plus or Resection, the maximum number of points in a round is 25.*

Point – Residuals screen

The *Point residuals* screen lists the residuals for each observation to a point in the resection.

Use the *Point residuals* screen to do the following:

- To disable an observation, highlight it and then tap *Use*.
- To view the details of an observation, highlight it and then tap *Details*.
- To return back to the *Resection residuals* screen, tap *Back*.

Note - *If you have measured face 1 and face 2 observations to a point, turning off the observation for one face will also turn off the observation to the other face.*

WARNING - *If you turn off some (but not all) of the observations to a backsight point, the solution for the resection will be biased because there will be a different number of observations to each backsight point.*

Point details screen

The *Point details* screen shows the mean observation for a point in the resection.

Use the *Point details* screen to do the following:

- change whether the horizontal component or the vertical component of a point will be used in the resection calculation
- change the target height and/or prism constant for all observations to that point

Note - You can only change which components of a point will be used in the resection calculation if you have selected the compute station elevation option, and the observed point has a 3D grid position.

The *Used for* field shows the point components used in the resection calculation. See the following table.

Option	Description
H (2D)	Use only the horizontal values for that point in the calculation
V (1D)	Use only the vertical values for that point in the calculation
H,V (3D)	Use both the horizontal and vertical values for that point in the calculation

Resection results screen

The *Resection results* screen shows information about the resection solution.

Use the *Resection results* screen to do the following:

- To return to the *Resection residuals* screen, tap *Esc*.
- To store the resection, tap *Store*.

Note - During a resection, nothing is stored in the job until you tap *Store* in the *Results* screen.

Resection is complete.

Eccentric station setup

You can use the resection function to perform an eccentric station setup, where the station setup is performed in view of a close-by control point and in view of at least one backsight point. For example, use this setup if you cannot set up over the control point, or you cannot see any backsight points from the control point.

An eccentric station setup needs at least one angles and distance observation to a close-by control point, and one angles-only observation to a backsight point. Additional backsight points can also be observed during an eccentric station setup. You can measure backsight points with angles-only observations or with angles and distance observations.

For more information

[Prepare for a robotic survey](#)

[Station setups – Overview](#)

[Station setup](#)

[Measuring rounds in station setup plus or resection](#)

[Advanced geodetics support](#)

[Station setup plus](#)

[Traverse](#)

Refline

Refline is the process of establishing the position of an occupied point relative to a baseline. To perform a refline station establishment, take measurements to two known or unknown baseline definition points. Once this occupation point is defined, all subsequent points are stored in terms of the baseline using station and offset. This method is often used when setting out buildings parallel to other objects or boundaries.

To perform a refline station setup:

1. From the main menu, select *Measure / <Style name> / Refline*.
2. Set the [corrections](#) associated with the instrument.
If the *Corrections* form does not appear, tap *Options* and then select the *Show corrections on startup* check box.
3. Enter an *Instrument point name* and *Instrument height*, if applicable.
When measuring to the bottom notch on a Trimble total station, tap  and then select *Bottom notch*. Enter the height measured to the top ridge of the bottom notch on the instrument. General Survey corrects this measured slope value to true vertical and adds the offset (*Ho*) to calculate true vertical to the trunnion axis. For details, see figure and tables in [Station setups – Overview](#).
4. Tap *Accept*.
5. Enter the *Point 1 name*, and *Target height*.
 - If point 1 has known coordinates, the coordinates are displayed.
 - If point 1 does not have known coordinates, default coordinates are used. Select *Options* to change the default coordinates.
6. Tap *Meas 1* to measure the first point.
7. Enter the *Point 2 name*, and *Target height*.
 - If point 1 has known coordinates, a point with known coordinates can be used for point 2.
 - If point 1 does not have known coordinates then a point with known coordinates can not be used at point 2.
 - If point 1 does not have known coordinates, the default coordinates are used. Select *Options* to change the default coordinates.
 - If point 1 and point 2 had known coordinates the computed refline azimuth is displayed, otherwise the default azimuth 0° is displayed.
8. Enter a *Refline azimuth*, if applicable.

9. Tap *Meas 2* to measure the second point.

The instrument point coordinates are displayed.

10. Tap *Store* to complete the refine station establishment.

Once the Refline setup is stored, all subsequent points are stored in terms of the baseline as a station and offset.

If a line does not already exist, one is automatically created between the two points, using the naming scheme "<Point 1 name>-<Point 2 name>". You can enter the *Start station* and *Station interval*.

If the line between the two points does already exist, the existing station is used and cannot be modified.

Note - In a refine station establishment, you can only use existing points that can be viewed as grid coordinates. This is because the refine calculation is a grid calculation. You can use 2D and 3D grid coordinates to define the baseline.

For more information

[Station setups – Overview](#)

Station setup plus, resection, and rounds options

There are up to four main settings that control the order in which the observations are taken, and how many observations are made during station setup plus, resection, and rounds:

- [Face order](#)
- [Observation order](#)
- [Sets per point](#)
- [Number of rounds](#)

Face order options

- *F1 only* - observations are taken only on face 1
- *F1... F2...* - all face 1 observations are taken to all points and then all face 2 observations are taken to all points
- *F1/F2...* - face 1 and then face 2 observations are taken to the first point, face 1 and then face 2 observations are taken to the next point, and so on

Observation order options

- *123.. 123*
- *123.. 321*

When the *Face order* is set to *F1... F2...* :

- *123.. 123* - observations on face 2 are taken in the same order as the observations on face 1
- *123.. 321* - observations on face 2 are taken in the reverse order to the observations on face 1

When the *Face order* is set to *F1 only* or *F1/F2* :

- 123.. 123 - each round of observations is taken in the same order
- 123.. 321 - every alternate round of observations is taken in the opposite order

Sets per point option

This option can be used to measure multiple sets of face 1 observations, or face 1 and face 2 observations to a point per round of observations.

If *Face order* is set to collect F1 and F2 observations, the *Sets per point* was set to 3, and the *Number of rounds* was set to 1, then the total number of observations to each point would be; $2 \times 3 \times 1 = 6$. Setting the *Sets per point* option to a number greater than 1 enables you to collect more than one set of observations to a point with only one visit to that location.

This option is currently available only in rounds.

Note - Before using this option please make sure this data collection technique matches your QA/QC requirements.

Number of rounds option

This option controls the number of complete rounds of observations that are taken to each point.

Skipping observations

When using *Automate rounds* you can configure the software to automatically skip obstructed foresight targets.

If the instrument cannot measure the point and *Skip obstructed foresights* is **enabled**, it skips that point and moves onto the next point in the rounds list.

If the instrument cannot measure the point and *Skip obstructed foresights* is **disabled**, a message appears after 60 seconds to indicate that the prism is obstructed.

The General Survey software continues to try to measure to the target until instructed to skip the point. To do this, tap *Ok* for the obstructed prism message, tap *Pause* and then tap *Skip*.

When the General Survey software reaches the end of a rounds list in which points have been skipped, the following message appears:

Observe skipped points?

Tap *Yes* to observe the points that were skipped during that round. The observations can be skipped again if required. Tap *No* to end the round.

If a point is skipped in one round, all subsequent rounds continue to prompt for observations to that point.

When one observation from a pair of face 1 and face 2 observations has been skipped, the unused observation is automatically deleted by the General Survey software. Deleted observations are stored in the General Survey database and can be undeleted. Undeleted observations can be processed in the office software, but are not automatically used to recompute Mean Turned Angle (MTA) records in the General Survey software.

Backsight observations cannot be skipped using the *Skip obstructed foresights* option.

Automate rounds

The *Automate rounds* option is available for Trimble servo total stations. When you select *Automate rounds*, the instrument automatically completes all rounds after the rounds list has been built.

A 3-second delay between automated rounds enables you to check the standard deviations before the next round starts automatically.

If a target has been blocked, the instrument tries to measure the point for up to 60 seconds. After 60 seconds has elapsed it skips the observation and moves to the next point in the rounds list.

If you tap *+ Round* after the instrument has completed the required number of rounds, the instrument performs one more round of observations. If you want the instrument to perform more than one extra round, enter the total number of required rounds **before** you tap *+ Round*.

For example, to measure three rounds automatically, and then measure another three rounds:

1. Enter 3 in the *Number of rounds* field.
2. Once the instrument has measured 3 rounds, enter 6 in the *Number of rounds* field.
3. Tap *+ Round*. The instrument measures the second group of 3 rounds.

Note - *Manually observed targets are automatically paused.*

Monitoring

When *Automated rounds* is enabled, monitoring controls are also enabled. Enter a value for the time delay between automated rounds.

With a Trimble servo total stations, you can automatically measure to non-active targets. To do this, select the *Auto-measure passive targets* check box.

Note - *If you select the Auto-measure passive targets check box, manually observed targets are automatically measured rather than paused. If you clear this check box, the software prompts you to aim the instrument to non-active targets.*

Conventional instrument corrections

You can set the corrections associated with conventional observations.

Note - *If you intend to perform a network adjustment in the Trimble Business Center software using data from a conventional survey, make sure that you enter a pressure, temperature and, curvature and refraction correction.*

Use the *PPM* (Parts Per Million) field to specify a PPM correction to be applied to electronic distance measurements. Key in the PPM correction, or enter the pressure and temperature of the surrounding environment and let the General Survey software compute the correction.

Typical pressure ranges are between 500 mbar - 1200 mbar, but when you work in an area with over-pressure (for example, a tunnel), larger pressures up to 3500 mbar are possible.

Note - *If you are using a Trimble total station that has an internal pressure sensor, the pressure field is set automatically from the sensor in the instrument. To disable this, tap the advanced pop-up arrow and then clear the From instrument check box.*

Use the *Curvature* and *Refraction* fields to control curvature and refraction corrections. The earth curvature and refraction corrections are applied to vertical angle observations and therefore have

an impact on computed vertical distance values. They also affect the horizontal distance values to a very small extent.

The earth curvature and refraction corrections can be applied independently using the options provided. The earth curvature correction is the most significant correction with a magnitude of approximately 16" per km measured distance (subtracted from the zenith vertical angle).

The magnitude of the refraction correction is affected by the refraction coefficient, which is an estimate of the change in air density along the light path from the instrument to the target. Since this change in air density is affected by factors such as temperature, ground conditions, and the height of the light path over ground, it is very difficult to determine exactly which refraction coefficient to use. If you use typical refraction coefficients such as 0.13, 0.142, or 0.2, the refraction correction results in a correction in the opposite direction to the earth curvature correction with a magnitude of approximately one-seventh of the earth curvature correction.

Note - The DC file format only supports a curvature and refraction correction that are both off, or both on, and when on, either with a coefficient of 0.142 or 0.2. When settings other than these are used in the General Survey software, the settings exported to the DC file will be a best match.

Note - Do not set corrections in both devices. To set them in the General Survey software, make sure the instrument settings are null.

For some instruments, the General Survey software automatically checks to see if various corrections (PPM, prism constant, and curvature and refraction) are being applied correctly. If it finds that the corrections are being applied twice, a warning message appears.

In the following table, the * symbol in a field indicates that the correction at the top of that column is applied.

Note - '*' applies only to computed coordinates when a station setup has been defined.

Displayed/Stored data	Corrections applied										
	C/R	PPM	PC	SL	Orient	Inst ht	Tar ht	Proj Cor	Stn SF	NA	POC
Status line	-	-	-	-	-	-	-	-	-	-	-
HA VA SD (raw)	-	-	-	-	-	-	-	-	-	-	-
HA VA SD	*	*	*	-	-	-	-	-	-	-	*
Az VA SD	*	*	*	-	*	-	-	-	-	-	*
Az HD VD	*	*	*	-	*	*	*	*	*	-	*
HA HD VD	*	*	*	-	-	*	*	*	*	-	*
Grid	*	*	*	*	*	*	*	*	*	*	*
delta Grid	*	*	*	*	*	*	*	*	*	*	*
Station and offset	*	*	*	*	*	*	*	*	*	*	*
DC file (observations)	-	-	-	-	-	-	-	-	-	-	*
DC file (reduced coordinates)	*	*	*	*	*	*	*	*	*	*	*
JobXML (observations)	-	-	-	-	-	-	-	-	-	-	*
JobXML (reduced)	*	*	*	*	*	*	*	*	*	*	*

Displayed/Stored data	Corrections applied										
	C/R	PPM	PC	SL	Orient	Inst ht	Tar ht	Proj Cor	Stn SF	NA	POC
coordinates)											
Survey Basic	*	*	*	*	*	*	*	*	*	*	*

The following table explains the corrections used above.

Correction	Description
C/R	Curvature and/or Refraction correction.
PPM	Atmospheric parts per million (PPM) correction. PPM is calculated from temperature and pressure.
PC	Prism constant correction.
SL	Sea level (ellipsoid) correction. This correction is applied only if a fully defined coordinate system definition is being used; the correction is not applied in the <i>Scale factor only</i> definition.
Orient	Orientation correction.
Inst ht	Instrument height correction.
Tar ht	Target height correction.
Proj Cor	Projection correction. This includes the application of a scale factor specified in the <i>Scale factor only</i> definition.
Stn SF	Station setup scale factor. In any station setup, a scale factor for this setup can be specified or computed. This scale factor is applied in the reduction of all observations from this station setup.
NA	Neighborhood adjustment. In a station setup defined using <i>station setup plus</i> or <i>resection</i> , a neighborhood adjustment can be applied. The neighborhood adjustment is computed based on the observed residuals to the control points used during the station setup. The adjustment is applied, using the specified exponent value, in the reduction of all observations from this station setup.
POC	Prism offset correction. This is only applied when using a Trimble VX/S Series 360° prism, R10 360° prism, MultiTrack target, or Active Track 360 target.

Target details

You can configure the details of the target during a conventional survey.

For information on tracking specific target types, see [Target tracking](#).

Changing the target

When connected to a conventional instrument the Target icon appears in the status bar. The number next to the target icon indicates the target currently in use. To alternate between targets or to edit the target height and the [prism constant](#), tap the target icon or press Ctrl + P. To select the target to use, tap the appropriate target in the pop-up list. You can create up to nine non-DR targets. By default, the targets are named Target 1 to Target 9. If you edit the display name of the target, the number of the target is appended to the display name.

Tip - To change to a target, select the target name. To edit entries in the *Target* form, select the target height or prism constant.

Target settings

Note - If you are using a Trimble total station that has an internal pressure sensor, the *Pressure* field is set automatically from the sensor in the instrument. To disable this, tap the advanced pop-up arrow and then clear the *From instrument* check box.

When using Trimble prisms, select the *Prism type* to automatically define the prism constant. When using non-Trimble prisms, select *Custom* to manually enter the prism constant.

Ensure that the correct prism type and mode is selected in the target form. This will ensure that the appropriate correction values are applied to the slope distance and vertical angle for geocentric offset and prism constant.

The correction is only significant when observing step vertical angles.

When connected to a DR instrument, Target DR is used to define the DR target height and prism constant. To enable DR, select Target DR. To disable DR and return the instrument to its last state, select target 1 - 9.

When measuring to the bottom notch on a Trimble prism base, tap the advanced pop-up arrow () and then select *Bottom notch*. General Survey corrects this measured slope value to true vertical and adds the offset 0.158 m (0.518 sft) to calculate the true vertical height to the center of the prism.

Note - If you select *Bottom notch*, the minimum slope distance (*Hm*) that you can enter is 0.300 meters. This is approximately the minimum slope distance that can be physically measured. If this minimum is too low, you must measure to the top mark.

For information on configuring an integrated survey rover survey rod see, [Integrated surveys](#).

For details, see the following figure and table.

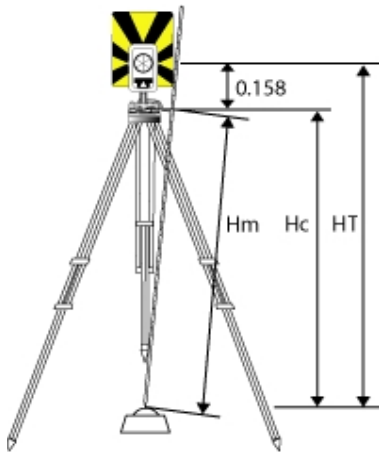

0.158m	Offset from bottom notch to center of prism.
Hm	Measured slope distance.
Hc	Hm corrected from slope to true vertical.
HT	True vertical target height. Hc + 0.158m.

Managing targets

Adding a new target

1. Tap the target icon in the status bar and then tap the height or prism constant for Target 1.
2. In the *Target 1* screen, tap *Add* to create Target 2.
3. Enter the details for *Target 2* and then tap *Accept*.
4. Target 2 now becomes the active target.

Deleting a target from the list

1. Tap the target icon in the status bar and then tap the height or prism constant.
2. In the *Target* screen, tap *Delete*. The Target is removed from the list.

Note - You cannot delete Target 1 or Target DR.

Editing a target height

1. Tap the target icon in the status bar.
2. Tap the target height for the target you want to edit.
3. Edit the target details and then tap *Accept*.

To edit target heights of observations already stored to the job, do one of the following:

- For a single observation or multiple observations using the same or different targets, use [Point manager](#).

- For a single target record, and subsequently a group of observations that use that target, use [Review job](#).

For more information

See also:

[Prism constant](#)

[Target tracking](#)

[Target controls](#)

Prism constant

The prism constant (distance offset) must be set for each prism that is used as a target in a conventional survey.

To edit a prism constant:

1. Tap the target icon in the status bar.
2. Tap the prism constant for the target you want to edit.
3. Edit the prism constant details and then tap *Accept*.

Enter a negative value if the prism constant is to be subtracted from measured distances.
Enter the Prism constant in millimeters (mm).

When using a Trimble total station, all corrections are applied in General Survey.

For some non-Trimble instruments, the General Survey software checks to see if a prism constant has been applied by the instrument **and** the software. When you select *Station setup*, status line messages show what has or has not been checked.

If the General Survey software cannot check the setting on the conventional instrument, do one of the following:

- If there is a prism constant set on the instrument, make sure that the prism constant in the General Survey software is set to 0.000.
- If there is a prism constant set in the General Survey software, make sure that the prism constant in the instrument is set to 0.000.

To review or edit the prism constant on previously stored observations, tap *Favorites / Review job* or tap *Jobs / Point manager*. For more information, see [Point manager](#).

GDM CU programs

General Survey offers similar functionality to the GDM Control Unit.

To access GDM CU programs, tap the instrument icon to access instrument functions and then enter the GDM CU program number.

The following table shows where to find specific GDM CU programs within General Survey.

GDM CU program	General Survey		
	Select ...	to ...	Instrument functions number
20 - Station setup	<i>Measure / Station setup</i>	perform a known station setup.	20
	<i>Measure / Station setup plus</i>	perform a known station plus setup.	
	<i>Measure / Resection</i>	perform a free station or eccentric station setup.	
	<i>Measure / Refline</i>	perform an instrument setup relative to a known or unknown baseline	
21 - Z/IZ	<i>Measure / Station elevation</i>	calculate an instrument elevation	21
22 - Angle measurement	<i>Measure / Measure rounds</i>	measure one or more Face 1 (CI) and Face 2 (CII) measurements.	22
	<i>Measure / Measure topo</i>	measure individual Face 1 and/or Face 2 measurements.	30
23 - Set Out	<i>Stakeout / Points</i>	set out points with known coordinates. Points can be defined via <i>Key in / Points</i> or obtained from a linked CSV, TXT or General Survey JOB file.	23
24 - Refline	<i>Stakeout / Lines</i>	measure or set out relative to a line. The line can be defined through <i>Key in / Line</i> or imported to the General Survey job.	24
25 - Area Calculation	<i>COGO / Compute area</i>	calculate an area.	25
26 - Distob	<i>COGO / Compute inverse</i>	calculate an inverse between two points.	26
27 - Moving Coordinates Forward	the General Survey software stores raw data and automatically calculates point coordinates. There is no specific program required in the General Survey software to move coordinates forward. Instead, select <i>Station setup plus</i> or <i>Measure rounds</i> .		27
28 - Obstructed Point	<i>Measure / Measure topo</i> and set the method to <i>Dual-prism offset</i> .		28
29 - Roadline	<i>Stakeout / Alignments</i>	measure or set out relative to an alignment.	29

GDM CU program	General Survey		
	Select ...	to ...	Instrument functions number
30 - Measure Coordinates	<p>the General Survey software stores raw data and automatically calculates point coordinates.</p> <p>There is no specific program required in the General Survey software to measure coordinates. Instead, use <i>Measure topo</i>.</p> <p>Points can be exported to a CSV or TXT file, through <i>Jobs / Import/Export / Send data</i>, for use as a control file. To access the control file from another job, select the CSV, TXT, or JOB file as a linked file through <i>Jobs / Properties of job</i>.</p>		30
32 - Angle measurement plus	<i>Measure / Measure rounds</i>	measure one or more Face 1 (CI) and Face 2 (CII) measurements.	32
	<i>Measure / Measure rounds / Options</i>	configure the number of rounds to be measured; select automatic measurements; set the observation order; measure distances on Face 2(CII); define a time interval between rounds (automatic measurements only).	
33 - Robotic Lite	Not supported -		
39 - Roadline 3D	<i>Stakeout / Alignments</i>	measure or set out relative to an alignment.	39
43 - Enter coordinates	<i>Key in / Points</i>	enter the coordinates for a point.	43
45 - Pcode	the Trimble Access menu tap <i>Feature libraries</i>	create a feature library with codes. To create a full feature library, or a feature library with both codes and attributes, use Feature and Attribute Editor or Autodraft Configuration File Editor. You can then transfer the feature library to the controller.	45
60 - Athletics	Not Supported		
61 - COGO	<i>COGO / Compute point</i>	perform similar coordinate calculations.	61
65 - Direct Reflex	<i>COGO / Compute point</i>	perform a From a baseline (Corner + distance), Brng-Line intersect (Corner + angle), or Four point intersection (Two lines intersection) measurement.	65
	<i>Measure / Measure topo</i>	perform a Circular Object (Eccentric object) measurement.	

GDM CU program	General Survey		
	Select ...	to ...	Instrument functions number
	<i>Measure / Surface scan</i>	perform a surface scan.	
66 - Monitoring	<i>Measure / Measure rounds</i>	configure the number of rounds to be measured, automatically store points, and define a time interval between rounds.	66
	<i>Measure / Measure rounds / Options</i>		
Menu 2 (View/Edit)	<i>Jobs / Review job</i>	review and edit the data stored in the job.	
	<i>Favorites / Review</i>		
	<i>Favorites / Point manager</i>		
F 6 (Change target height)	the target icon on the status bar	quickly change the target details for new observations.	
F 33 (Change prism constant)			
Edit target height or Prism constant	<i>Favorites / Review job</i>	edit the target record to change the target height or prism constant. Changes then apply to all observations that use that target.	
	<i>Favorites / Point manager</i>	use <i>Point manager</i> to edit the height or prism constant values for individual observations For more information, refer to the Help.	
GDM Job Files export	Trimble Data Transfer (connected to General Survey)	transfer the GDM Job file. For more information about transferring data, see Transferring files between the controller and the office computer.	
	<i>Jobs / Import/Export / Export custom format</i>	create a GDM Job file	

Advanced Geodetic support

To enable the following options for Advanced Geodetic support:

When creating a new job, tap *Job / New job / Cogo settings*; for an existing job, tap *Job / Properties of job / Cogo settings*.

- [Station setup scale factor](#)
- [Helmert transformation for resection](#)

Station setup scale factor

When you turn on Advanced Geodetic support, you can apply an additional scale factor to every conventional station setup. All measured horizontal distances are adjusted by this scale factor. To configure the scale factor settings, select *Options* during a [station setup](#), [station setup plus](#), or [resection](#).

This station setup scale factor can be Free (computed) or Fixed. If you have chosen to compute a station setup scale factor, you must observe at least one distance to a backsight during the station setup so that a scale factor can be calculated.

Helmert transformation for resection

When you turn on Advanced Geodetic support, *Resection* has an additional computation method called Helmert transformation. To perform a resection using a Helmert transformation, select *Options* during a *Resection*, and then set the *Resection type* to *Helmert*.

Note - *The standard resection type is the same as the resection method used when Advanced Geodetics is turned off.*

For a Helmert transformation, you must measure distances to the backsight points. The resection calculation will not use a backsight point without a distance measurement.

For more information, see [Neighborhood adjustment](#).

Start the survey

To begin surveying, select the required survey method from [Measure](#).

Note - *If there is only one survey style, it is automatically selected when you start a survey. Otherwise, select a style from the list that appears.*

End the survey

1. From the main menu, select *Measure / End conventional survey*.
2. Tap *Yes* to confirm.
3. Turn off the controller.

WARNING - The current station setup is lost when you select *End conventional survey*.

If a survey is running, end it before editing the current survey style or changing survey styles. You must also end the survey before accessing job functions such as copying. For more information, see [Managing jobs](#).

Conventional Survey – Measure

Measuring points in a conventional survey

The *Measure* screen lets you record points measured using data from the connected conventional survey instrument. For information on setting up the instrument, see [Conventional survey – Getting started](#).

To access the *Measure* screen, from the main menu tap *Measure*. The following measurements or calculations can be performed from the *Measure* screen:

To...	From the <i>Measure</i> screen, select...	And then...
Measure a topographic point	<i>Measure topo</i>	
Measure points with feature codes	<i>Measure codes</i> or <i>Measure topo</i>	
Measure multiple sets of observations	<i>Measure rounds</i>	
Define a plane and then measure points relative to the plane	<i>Measure points on a plane</i>	
Measure a point relative to a 3D axis	<i>Measure 3D axes</i>	
Measure a line of points at a fixed interval	<i>Continuous topo</i>	
Define a surface and then scan points on the surface	<i>Scanning</i> or <i>Surface scan</i>	
Measure an inaccessible point	<i>Measure topo</i>	Select the <i>Distance offset</i> or the appropriate <i>angle offset</i> method
Measure a point that cannot be observed directly with a pole in plumb position	<i>Measure topo</i>	Select the <i>Dual-prism offset</i> method
Measure to a cylindrical object, and calculate the center point and radius of the object such as a pillar or water tank	<i>Measure topo</i>	Select the <i>Circular object</i> method
Calculate the height and/or width of a remote object if the instrument cannot easily measure a distance directly to the	<i>Measure topo</i>	Select the <i>Remote object</i> method

To...	From the <i>Measure</i> screen, select...	And then...
object		
Measure a check class point	<i>Measure topo</i> Press CTRL + K	Tap the <i>Check</i> softkey

The General Survey software also enables you to:

- [Capture panoramas when measuring points](#) if the controller is connected to a Trimble V10 imaging rover.
- [Capture a panorama](#) without measuring a point or performing a scan using a total station that has Trimble VISION technology.
- Measure and automatically store a construction point. For more information, see [Fast fix](#).
- [Measure a point on two faces](#).

Tip - In *Point name* fields there is a *Find* softkey that lets you search for the next available point name. For example, if your job contains points numbered in the 1000s, 2000s and 3000s, and you want to find the next available point name after 1000:

1. In the *Point name* field, tap *Find*. The *Find next free point name* screen appears.
2. Enter the point name you want to start searching from (in this example, 1000) and tap *Enter*.

The General Survey software searches for the next available point name after 1000 and inserts it in the *Point name* field.

Measuring topo points in a conventional survey

To measure a topographic point using the General Survey software and a conventional instrument:

1. From the *Measure* menu, select *Measure topo*.
2. Enter a value in the *Point name* field.
3. If necessary, enter a feature code in the *Code* field.
If the code has attributes, see [Using feature codes with predefined attributes](#).
4. If you have enabled a measured point to be added to a CSV file, select the *Add to CSV file* option. The point will be stored in the displayed file name. To enable adding a file, see [Add to CSV file](#).
5. In the *Method* field, select a measurement method.
6. Enter a value in the *Target height* field and then tap *Measure*.

When measuring to the bottom notch on a [Trimble prism base](#), tap the advanced pop-up arrow () and then select *Bottom notch*.

If you selected the [View before storage](#) check box in the survey style, the measurement information appears on the screen. If necessary, edit the target height and code. Tap the view display button on the left of the measurement information to change the display and then do one of the following:

- To store the point, tap *Store*.
- Turn the instrument to the next point and then tap *Read*. The last point is stored and a measurement is made to the next point.

If you did not select the [View before storage](#) check box, the point is stored automatically and the point name increments (based on the *Auto point step size* setting). The General Survey software stores the raw observations (HA, VA, and SD).

Notes

- *If you selected the Auto average option in the survey style, and an observation to a duplicate point is within the specified duplicate point tolerances, the observation and the computed average position (using all the available point positions), are automatically stored.*
- *Two angles only observations from two different known points can be 'averaged' to compute the coordinates of the intersection point. To average the observations, they must be stored with the same point name. When the Duplicate point: Out of tolerance screen appears, select Average. Alternatively, average the observations using [Compute average](#).*
- *Two averaging methods are supported.*
 - *Weighted*
 - *Unweighted*

You can select the averaging method in the [Cogo settings](#) screen.

To [change the settings for the current survey](#), tap *Options*. You cannot change the current survey style or the system settings.

If you are using a servo or robotic instrument to measure a known (coordinated) point, tap *Turn*. Alternatively, with a servo instrument, set the *Servo auto turn* field in the survey style to *HA & VA*, or *HA only* to automatically turn the instrument to the point.

Tips

- You can tap *Enter* while measuring an *Averaged observations* to accept the measurement before the required number of observations has been completed.
- You can tap *Enter* while measuring a *Direct Reflex (DR)* point with a defined standard deviation to accept the measurement before the standard deviation has been satisfied.
- Instead of going to the *Measure* screen, you can access the *Measure topo* screen from the following:
 - From the *Favorites* menu, select *Measure points*.
 - From the Map, select *Measure* (only available when nothing in the map is selected).
- If you are measuring topo points with feature codes, you may find [Measure codes](#) faster and easier to use than *Measure topo*.
- You can use the Trimble V10 imaging rover to [capture panoramas when measuring a point during a conventional survey](#).

If you are using a Leica TPS1100 instrument with *Measure topo*, you can initiate the measurement on the instrument and then store the measurement in the General Survey software. For more

information on how to do this and on how to configure the Leica TPS1100 instrument, see [Configuring a Leica TPS1100 instrument to record data to General Survey](#).

Measuring a point in two faces

To start a conventional survey in the General Survey software, you must first perform a *Station setup* using one of the following methods:

- [Station setup](#)
- [Station setup plus](#)
- [Resection](#)

You can observe points using face 1 (direct) and face 2 (reverse) measurements during a station setup and during [Measure rounds](#) or [Measure topo](#).

Consider the station setup and the new point measurement method together and choose which to use according to how you want to capture and store the data.

If you only want to use a single backsight (measured on one or both faces), and measure some topo points (on one or both faces), then use *station setup* and *Measure topo*. When you measure on both faces, remember to also measure the backsight on face 2 in *Measure topo*. Otherwise, all foresights on face 2 will be oriented using the face 1 backsight observation.

If you want to measure multiple backsights, measure multiple rounds, or obtain better quality control of your observations, see below for more information on different station setup and new point measurement methods in General Survey.

Use **Station setup plus** to:

- measure a single backsight point or multiple backsight points
- measure backsight and foresight points
- pair the face 1 and face 2 observations and create MTA records
- measure face 1 only observations and create MTA records
- measure one or more rounds of observations
- review the quality of the observations and remove bad observations

Use **Resection** to:

- coordinate the instrument point
- measure multiple backsight points
- measure backsight and foresight points
- pair the face 1 and face 2 observations and create MTA records
- measure face 1 only observations and create MTA records
- measure one or more rounds of observations
- review the quality of the observations and remove bad observations

Use **Station setup** to:

- perform a station setup with a single backsight measurement on one face only

Notes

- *When measuring points on both faces, use Measure topo to observe the backsight on the other face. Alternatively, use Measure rounds and include the observation to the backsight point in the rounds.*
- *When you make topo observations after a Station setup, and you subsequently select Measure rounds, you must reobserve the backsight to include it in the rounds, generate an MTA to the backsight, and calculate turned angles from the backsight MTA for all foresight points.*
- *MTAs are not created during Station setup, but are created later if you make further observations to the backsight using Measure topo or Measure rounds.*

Use **Measure rounds** (after performing a station setup) to:

- measure one or more foresight points
- pair the face 1 and face 2 observations and create MTA records
- measure face 1 only observations and create MTA records
- measure one or more [sets of observations per point](#) in one round
- measure one or more rounds of observations
- review the standard deviations of the observations and remove bad observations

Notes

- *Standard deviations are only available after the second round of observations.*
- *If the station setup has a single backsight (from Station setup or Station setup plus), you can choose whether or not to include the backsight point in the rounds list.*
- *If the station setup has multiple backsights (from Station setup plus or Resection), the backsight points are not included in the rounds list.*
- *If you do not measure the backsight on face 2, then the horizontal angle face 2 measurements that were observed using Measure rounds will not be used when calculating the MTAs.*
- *When you use Measure rounds after a station setup with a single backsight, and you do not include the backsight point in the rounds list, all turned angles are calculated using the backsight observation(s) made during the station setup.*

Use **Measure topo** (after performing a station setup) to:

- measure face 1 or face 2 observations and create MTA records

Note - *You can measure multiple rounds using Measure topo. However, Trimble recommends Measure rounds as a more suitable method to use.*

Additional notes about MTA records

- *When you use Station setup plus or Resection, all observations are stored when the station setup is complete. When you use Measure rounds, the observations are stored at the end of each round. In all three options, the MTAs are stored at the end.*
- *When you use Measure topo, MTAs are calculated and stored on the fly.*
- *You can create MTAs during a station setup using Station setup plus and Resection, and also after a station setup using Measure rounds or Measure topo. When you measure the same point(s) using Measure rounds or Measure topo after Station setup plus and Resection, the*

General Survey software may produce two MTAs for the one point. When more than one MTA exists for the same point in one station setup, the General Survey software always uses the first MTA. To avoid having two MTAs for the same point, do not use both methods to measure a point.

- *Once an MTA record is written to the job database, you cannot change it.*
- *You can delete a face 1 and face 2 observation but the MTA records are not updated.*
- *You cannot delete MTA records in review.*
- *In Station setup plus, Resection, or Measure rounds, when you use the F1... F2 or F1/F2... face order, MTAs that are created pair face 1 and face 2 observations.*
- *In Station setup plus, Resection, or Measure rounds, when you use the F1 only face order, MTAs that are created group face 1 observations.*
- *In Measure topo, MTAs that are created group together all observations for the same point.*

Continuous topo – conventional

Use the *Continuous topo* function to measure points continuously.

A point is stored when one of the following conditions occurs:

- a predefined time has elapsed
- a predefined distance has been exceeded
- both predefined time and/or distance settings have been met
- a predefined stop time and distance settings have been met

Measuring continuous topo points

1. From the main menu, select *Measure / Continuous topo*.
2. Enter a value in the *Start point name* field. This increments automatically.
3. Enter a value in the *Target height* field.
4. In the *Method* field, select *Fixed distance*, *Fixed time*, *Time and distance*, or *Time or Distance*.
5. Enter a value in the *Distance* field and/or the *Time interval* field, depending on which method you are using.
6. Tap *Start* to start recording data and then move along the feature to be surveyed.
7. To stop measuring continuous points, tap *End*.

Tip - To store a position before the predefined conditions have been met, tap *Store*.

Synchronous and non-synchronous angles and distances

Continuous topo with a Trimble total station uses only synchronous angles and distances.

When using any other instrument with continuous topo, for example a Trimble 5600 total station, the General Survey software uses the latest angles and the latest distance when it stores a position. When a synchronized angle and distance is not available (within approximately 1 second) a newer

angle may be paired with an older distance. To minimize any potential position error, you may need to slow the prism movement during Continuous topo.

Measuring continuous topo points using the stop and go method

1. From the main menu, select *Measure / Continuous topo*.
2. Enter a value in the *Start point name* field. This increments automatically.
3. Enter a value in the *Target height* field.
4. In the *Method* field select *Stop and go*.
5. Enter a value in the *Stop time* field for the period of time the target must be stationary before the instrument starts to measure the point.

The user is deemed to be stationary when their velocity is less than 5 cm/sec.

6. Enter a value in the *Distance* field for the minimum distance between points.

When you use an instrument that has a tracklight that has been enabled, the tracklight will be disabled for 2 seconds when the measured point has been stored.

Using an echo sounder to store depths

You can use continuous topo to store depths with measured points.

To configure the survey style:

1. From the Trimble Access menu, tap *Settings / Survey styles / <Style name>*.
2. Tap *Echo sounder*.
3. Select an **instrument** from the *Type* field.
4. Configure the *Controller port*:
 - If you set the *Controller port* to Bluetooth, you must configure the echo sounder **Bluetooth** settings.
 - If you set the *Controller port* to COM1 or COM2, you must configure the port settings.
5. If required, enter the *Latency* and *Draft* and then tap *Accept*.

The latency caters for echo sounders where the depth is received by the controller after the position. General Survey software uses the latency to match and store the depth when it is received with continuous topo points that were saved previously.

6. Tap *Accept* and then tap *Store* to save the changes.

To store continuous topo points with depths, follow the steps above to [Measure continuous topo points](#), while connected to the echo sounder with a correctly configured survey style.

Notes

- *During the survey, you can disable storing depths with continuous topo points. To do this, tap Options and then clear the Use echo sounder check box. You can also configure Latency and Draft from Options.*
- *The Draft affects how the target height is measured. If the Draft is 0.00, the target height is the distance from the transducer to the prism. If a Draft is specified, the target height is the distance from the transducer to the prism, minus the draft.*

When measuring continuous topo points with an echo sounder enabled, a depth is displayed during continuous topo, and also in the map. When a latency has been configured the continuous topo points are initially stored without depths and later updated. The depth that is displayed during continuous topo when a latency has been configured, is an indicator that depths are being received. The depths that are displayed may not be the depths that are stored with the point names that are displayed at the same time.

CAUTION - There are many factors involved in correctly pairing positions with accurate depths. These include sound velocity - which varies with water temperature and salinity, hardware processing time, and the speed at which the boat is moving. Make sure that you use the appropriate techniques to achieve the required results.

The elevations of continuous topo points stored in General Survey software do not have the depth applied to them. Use *Export custom format* files to generate reports with depths applied.

The following sample reports are available for download from www.trimble.com/Survey/Trimble-Access-IS.aspx:

- [Survey report.xml]
- [Comma Delimited with elevation and depths.xml]
- [Comma Delimited with depth applied.xml]

Note - If a Sonarmite instrument is connected, General Survey software configures it to use the correct output format and mode. For an instrument from another manufacturer, you must manually configure it to use the correct output format. For more information, see [Echo sounder instruments](#).

Angles and distance

In a conventional survey, use this measurement method to measure a point by angles and a distance.

To measure an angle offset when using the *Angles and distance* measurement method, tap *Dist* to measure and fix the distance, then turn the instrument. The distance will remain fixed but the horizontal and vertical angles will change.

Note - The distance reverts to ? if *target test* is enabled and the instrument is turned more than 30 cm from the target.

Angles only and H.Angle only

In a conventional survey, use this measurement method to measure a point by both a horizontal and vertical angle or by a horizontal angle only.

Averaged observations

In a conventional survey, use the averaged observations method to:

- increase the measurement precision with a predefined number of observations
- view the associated measurement standard deviations

To measure a point using the averaged observations method:

1. From the *Measure* menu, select *Measure topo*.
2. In the *Point name* field, enter the name of the point.
3. In the *Code* field, enter a feature code (optional).
4. Select *Averaged observations* as the method.
5. Sight the target and tap *Measure*.

While the instrument is carrying out the measurements, standard deviations are displayed for the horizontal (HA) and vertical (VA) angles, and the slope distance (SD).

6. View the resulting observation data, and the associated standard deviations, in the *Store* screen.

If acceptable, tap *Store*.

Note - Use the options available in the *Measure topo* screen to change the number of observations taken by the instrument using averaged observations.

Angle offset, H.Angle offset, and V.Angle offset

In a conventional survey, there are three angle offset methods that you can use to observe a point that is inaccessible; Angle offset, H.Angle offset, and V.Angle offset.

The *Angle offset* method holds the horizontal distance from the first observation, and combines this with the horizontal angle and vertical angle from the second observation to create an observation to the offset location.

The *V.Angle offset* method holds the horizontal distance and horizontal angle from the first observation, and combines this with the vertical angle from the second observation to create an observation to the offset location.

The *H.Angle offset* method holds the slope distance and vertical angle from the first observation, and combines this with the horizontal angle from the second observation to create an observation to the offset location.

All raw observables from the first and second observations are stored internally in the job file and are available in Custom ASCII Export.

Measuring a point using an angle offset method

1. From the *Measure* menu, select *Measure topo*.
2. In the *Point name* field, enter the name of the point.
3. In the *Code* field, enter a feature code (optional).
4. In the *Method* field, select *Angle offset*, *H. Angle Offset*, or *V. Angle Offset*.

When using the *H.Angle offset* measurement method, the target height from the first observation is applied to the horizontal angle offset observation.

When using *Angle offset* or *V.Angle offset* measurement methods you do not need to enter the *Target height*. The offset measurements are to the offset location and the target height is not used in any computations. To ensure that a target height is not applied to the

observation, a target height of 0 (zero) is automatically stored to the General Survey software database.

- Place the target beside the object to be measured, sight the target and then tap *Measure*. The first observation is displayed.

Tip - When using Autolock technology and measuring offset points, select the *Autolock off for offsets* check box. When enabled, Autolock technology is automatically disabled for the offset measurement and then re-enabled after the measurement.

- Turn to the offset location and then tap *Measure*. The two observations are combined into one:
 - if you selected the *View before storage* check box in the survey style, the measurement values appear. Tap *Store* to store the point.
 - if you did not select the *View before storage* check box, the point is stored automatically.

Note - The observation is stored in the database as raw HA, VA, and SD records.

Distance offset

In a conventional survey, use this observation method when a point is inaccessible but a horizontal distance from the target point to the object can be measured.

Distance offset allows you to offset in one, two, or three distances in one step.

Measuring a point using the distance offset method

- From the *Measure* menu, select *Measure topo*.
- In the *Point name* field, enter the name of the point.
- In the *Code* field, enter a feature code (optional).
- In the *Method* field, select *Distance offset*.
- In the *Target height* field, enter the height of the target.
- Tap *Options* and then set the *Offset & Stakeout directions* perspective.

Tip - From the *Options* screen you can also enter values in the *Custom L/R offset 1* and *Custom L/R offset 2* fields to pre-configure two values for the *L/R offset*.

- Enter the *L/R offset* (left or right offset) from the target to the object, if applicable. If custom offsets were preconfigured, tap the pop-up arrow to select the offset.

Tip - From the pop-up menu, tap *Set offsets to 0* to set all three offset values to 0. This option is also available from the *In/Out offset* and *V.Dist offset* fields.

Note - If all three fields are set to 0 the measurement will be treated as an *Angles and distance measurement*.

- Enter the *In/Out offset* from the target to the object, if applicable.
- Enter the *V.Dist offset* from the target to the object, if applicable.

The following figure shows an example where point 5 is measured with the *Offset & Stakeout directions* set to *Instrument perspective*:

- offset to the left (2) of the target (3)
- offset out (4) from the instrument station (1)
- offset vertically (6)

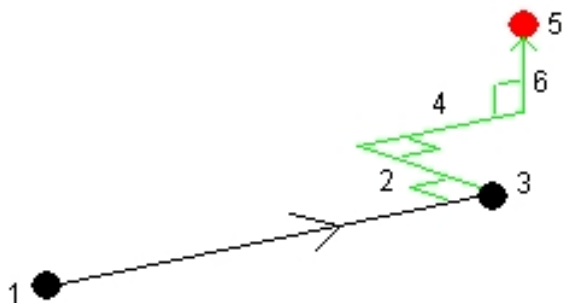

10. Tap *Measure*.

If you selected the *View before storage* check box in the survey style, the observation adjusted for the offset distance appears. Tap *Store* to store the point.

If you did not select the *View before storage* check box, the point is stored automatically.

The General Survey software stores the adjusted horizontal angle, vertical angle, and slope distance in the point record, as well as an offset record with the offset measurement details.

Offset and stakeout directions

The left and right directions used in *Distance offset* depend on the *Offset & Stakeout directions* setting. You can configure this setting in the survey style and also from *Options*.

When looking from the instrument to the object, an object that is offset to the left when the *Offset & Stakeout directions* are set to *Instrument perspective* is to the left.

When the *Offset & Stakeout directions* is set to *Target perspective*, the object is to the right.

When the *Offset & Stakeout directions* are set to *Automatic*, the offset and stakeout directions are with respect to the *instrument* perspective in a Servo survey, and to the *target* perspective in a Robotic survey.

The measurements are editable in *Review job* and are always displayed in the perspective in which they were observed. The perspective cannot be changed in review. The measurement is always stored relative to the instrument position.

Measure points on a plane

In a conventional survey, the Measure points on a plane measurement method is used to define a plane and then measure points relative to the plane.

A horizontal plane, a vertical plane, or a tilted plane can be defined by selecting points in the job or measuring new points. After defining the plane, an *Angles only* measurement to the plane creates an angle and computed distance observation onto the plane. Alternatively, an *Angles and distance measurement* to the plane computes the perpendicular offset to the plane.

The type of plane calculated by the software depends on the number of points selected:

No. of points	Plane type
1	Horizontal
2	Vertical through 2 points
3 or more	Plane with residuals (for 3 points, the residuals will be 0). The plane can be a "Free" plane created as a best fit (typically tilted) plane through all points, or a "Vertical" plane constrained to a best fit vertical plane through all points. Tap the <i>Free / Vertical</i> softkey to toggle between the two modes.

1. From the main menu, select *Measure / Measure points on plane*.
2. To define the plane:
 - a. Either tap *Add* to select the [point selection method](#) and then select the point(s) to use to define the plane, or tap *Measure* to go to the *Measure point* screen and measure a new point to use in the plane definition. Add or measure at least enough points to define the required plane.
 - b. Tap *Calculate* to calculate the plane.
 - c. If the plane uses 3 or more points, you can tap *Vertical* to calculate a vertically constrained plane. If required, tap *Free* to recalculate the plane using the best fit through all points.
 - d. Use the values in the *Residuals* column to identify any points that you want to exclude. Tap a row in the table to exclude or include a point and automatically recalculate the plane. The values in the *Residuals* column are updated.
3. Tap *Continue* to measure points relative to the plane.
4. Enter a *Point name*.
5. Select the *Method* to use for calculating the point:
 - *Angle and distance* calculates coordinates for the measured point as well as the distance from the point to the plane.
 - *Angle only* calculates coordinates for the observed point using the intersection of measured angles and the plane.
6. Tap *Measure*.
7. Tap *Store* to store the point in the database.

Tip - When measuring with *Angles and distance*, configure the instrument [EDM settings](#) to turn on tracking mode to see the delta distance to the plane field update in real time.

Measure 3D axes

To measure a point relative to a 3D axis using General Survey and a conventional instrument:

1. From the *Measure* menu, select *Measure 3D axes*.
2. Key in or measure the two points that define a 3D axis.

Tip - To measure a point, tap the pop-up menu button on the point name field and select *Measure* from the list of options displayed.

3. Tap *Options* to select the format of the delta display for the points measured relative to the axis.

The content and format of the delta display is controlled by XSLT style sheets. Translated default XSLT Measure 3D Axes Style Sheet (*.3ds) files are included with the language files, and accessed by General Survey from the language folders. You can create new formats in the office and then copy them to the [Systems files] folder on the controller.

4. Tap *Next*.

The instrument is automatically put into TRK mode. When General Survey receives a distance, the deltas fields are automatically updated.

If you are not measuring to a prism, use Instrument functions to set DR mode.

You can accept the TRK measurement, or tap *Measure* to take an STD measurement.

The General Survey software reports the coordinates and elevation for the measured point, and the orthogonal and vertical deltas for the point relative to the 3D axis. The following diagram and table describes the reported deltas using the default format.

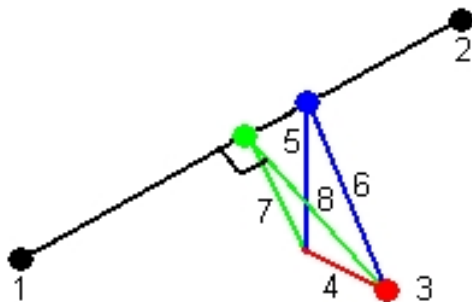

1 Point 1 defining the 3D axis	5 Vertical offset to vertical point on 3D axis
2 Point 2 defining the 3D axis	6 Radial offset to vertical point on 3D axis
3 Measured point	7 Perpendicular offset to orthogonal point on 3D axis
4 Horizontal offset to 3D axis	8 Radial offset to orthogonal point on 3D axis

General Survey also reports the:

- distance from Point 1 and Point 2 to the calculated orthogonal point on the 3D axis
- distance from Point 1 and Point 2 to the calculated vertical point on the 3D axis
- coordinates and elevation for the calculated orthogonal and vertical points on the 3D axis

5. To store the measurement, enter a *Point name*, and a *Code*, if required, and then tap *Store*. You can continue to measure and store additional points.

Tip - Tap *Back* to define a new 3D axis or to change the deltas display format.

Notes

- *Descriptions and Attributes are not supported.*
- *The style sheet that you selected in Measure / Measure 3D axes is used when displaying 3D axes records in Jobs / Review job.*
- *If points 1 and 2 define a vertical axis, all vertical deltas show as null (?).*

Dual-prism offset

In a conventional survey, use this measurement method to coordinate a point that cannot be observed directly with a pole in a plumb position.

Note - *The use of a tiltable prism with the appropriate nodal offset will give accurate results regardless of the direction of pole tilt. Prisms such as the Trimble VX/S Series 360° do not correct the vertical angle and slope distance for the difference between the optical center of the prism and the center line of the rod.*

To measure a point using the dual-prism offset method:

1. As shown in the following diagram, space two prisms (A and B) apart on the range pole. The distance BC is known.

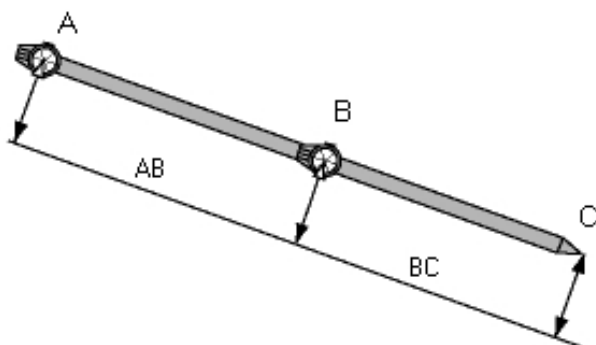

2. From the main menu, select *Measure* and then perform a station setup. See [Station setups – Overview](#).
3. From the *Measure* menu, select *Measure topo*.
4. In the *Point name* field, enter the name of the point.
5. In the *Code* field, enter a feature code (optional).
6. In the *Method* field, select *Dual-prism offset*.
7. Complete the fields as required.

Tip - Enter a suitable *Tolerance AB* to generate a warning if there is a difference between the keyed-in distance AB between the two prisms and the measured distance AB between the two prisms. Exceeding the tolerance could indicate that the entered distance AB is incorrect, or it could indicate pole movement between the measurement to prism A and the measurement to prism B.

8. Take two measurements (tap *Measure*).

The General Survey software calculates the obscured position (C) and then stores it as a raw HA VA SD observation.

All raw observations are stored internally in the job file and are available in Custom ASCII Export.

Circular object

In a conventional survey, use this measurement method to calculate the center point of a circular object, such as a water tank or silo. To do this:

1. From the *Measure* menu, select *Measure topo*.
2. Use the *Circular object* method to measure an angle and distance to the front center face of the circular object.

There are two different workflows you can use to measure a circular object; Bisect tangents (default) and Center + tangent. To configure the method, tap the arrow or press the Shift key to access the second row of softkeys in the *Measure topo* screen, tap *Options*, and then specify the Circular object method.

3. Do one of the following:
 - If you are using the bisect tangent method, you are prompted to point and measure an Angles only to the visible edges of the left and right sides of the circular object.

If the total station is motorized it automatically turns to the half angle between the Angles only measurements, and makes a DR measurement to a point on the circumference of the circular object. If the total station is not motorized you must turn the total station to the half angle so that it can complete the measurements. The two Angles only measurements and the third DR measurement are used to compute the radius of the circular object. The radius distance is added to the DR measurement and a raw HA VA SD observation to the center of the object is stored.

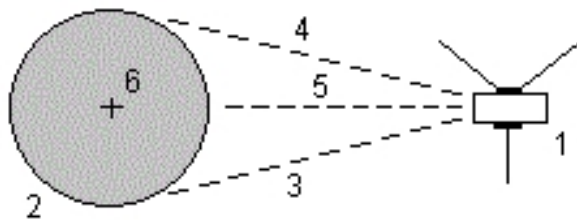

- | | | | |
|---------|--------------------------|---|------------------|
| 1 | Total station | 5 | DR measurement |
| 2 | Circular object | 6 | Center of object |
| 3 and 4 | Angles only measurements | | |

- If you are using the center + tangent method, measure an angle and distance to the front center face of the circular object, and then observe an angles only measurement to the side of the circular object.

From these two measurements, General Survey calculates the center point of the circular object and stores it as a raw HA VA SD observation. The radius is also calculated and stored with the observation.

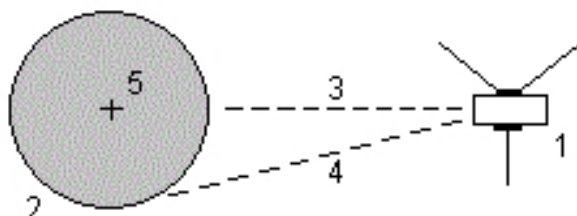

1	Total station	4	Angles only measurement
2	Circular object	5	Center of object
3	Angle and distance measurement		

Measure rounds

This topic describes how to measure multiple sets (rounds) of observations with a conventional instrument and the General Survey software.

A round can consist of one of the following:

- a set of single face 1 observations
- multiple sets of single face 1 observations
- a set of matched face 1 and face 2 observations
- multiple sets of matched face 1 and face 2 observations

Rounds can be used in a number of different ways depending on your equipment, the accessibility of points, and the procedures to observe the points, such as the order in which the observations are made.

Measuring rounds of observations

1. From the *Measure* menu, select *Measure rounds*.
2. Tap *Options* to [configure](#) the rounds options.
Before you start measuring points, make sure that the *Face order* and *Sets per point* settings are correct. You cannot change these settings after you start measuring points.
3. [Manually build the rounds list](#) by observing each point to include in the round on the first face.
4. Measure all points for subsequent rounds.

5. When all observations are complete, General Survey software shows the [Standard deviations screen](#).
6. Tap *Close* to save and exit rounds.

Notes

- *When using servo or robotic instruments, check that the instrument has sighted the target accurately. Manually adjust it if necessary. Some instruments can perform accurate sighting automatically. For information on the instrument specifications, refer to the instrument manufacturer's documentation.*
- *Select [Interrupted target measurement](#) if the measurement is likely to be interrupted, for example, when measuring in traffic.*
- *If you measure to static targets when there are two prisms close together, use [FineLock](#) or [Long Range FineLock](#) technology.*
 - *With a Trimble S8 total station equipped with [FineLock](#) technology, you can use [FineLock](#) mode when measuring to a prism that is 20 m - 700 m away.*
 - *With a Trimble S8 total station equipped with [Long Range FineLock](#) technology, you can use [Long Range FineLock](#) mode when measuring to a prism that is 250 m - 2500 m away.*
- *If you are using a servo or robotic instrument to measure a known (coordinated) point, tap *Turn*. Alternatively, with a servo instrument, set the *Servo auto turn* field in the survey style to *HA & VA*, or *HA* only to automatically turn the instrument to the point.*
- *If you tap *Esc* in the *Measure* screen, the current round is discarded.*
- *The top of the *Measure* rounds screen shows the following:*
 - *the current face observations*
 - *when you use more than one set per point, the number of the current set and the total number of sets to be measured (shown in brackets)*
 - *the number of the current round the total number of rounds to be measured (shown in brackets)*

For example, "Face 1 (2/2) (1/3)" shows that the instrument is on face 1 of the second set of two sets and the first of three rounds.

Building the rounds list manually

When you manually build the rounds list, the General Survey software automatically adds each point to the internal rounds list as it is measured for the first time. The rounds list contains all the information about each point such as point name, code, target height, prism constant, and target ID.

To manually add a point to the rounds list, and then measure rounds:

1. Choose to include or exclude the backsight observation.
See also [Including/excluding the backsight](#).
2. Follow the same procedure as for [measuring a topo point](#).

Note - *To specify the prism constant or the height of the target for each observation in the rounds list, tap the target icon. If the prism constant is to be subtracted from measured distances, enter a negative value. You cannot alter the prism constant or the target height*

for subsequent rounds. Instead, General Survey uses those values stored when building the rounds list.

3. When the rounds list is built, tap *End Face*. The General Survey software:
 - Defaults to the correct point details for each observed point.
 - Directs you to change face when required. With a servo-driven instrument, this happens automatically.
 - Automatically turns and measures when using [Autolock](#) or [FineLock](#) technology, and [Automated rounds](#) is enabled.
 - Displays the results. You can then delete bad data as required.

Notes

- You cannot add the same point to the rounds list more than once. To take more measurements to points already measured, tap *End face*.
- You cannot edit the rounds list. Before you tap *End face*, be sure to observe all points to include in the rounds observations.
- When measuring a DR target with a Trimble VX Spatial Station or Trimble S Series total station with automated rounds, the General Survey software will pause to allow you to sight to the target. You **must** manually sight and measure the point to continue.

Including/excluding the backsight from a set of rounds

Trimble recommends observing the backsight on both faces if you are taking foresight observations on both faces. If you exclude the backsight:

- the backsight observation(s) taken during the station setup is used to compute the MTA.
- if you do not measure the backsight on face 2 and there is only one single face observation to the backsight, and the rounds include observations on both faces, then the horizontal angle face 2 measurements observed using *Measure rounds* will not be used when calculating the MTAs.

Rounds – maximum number

The following limits apply in rounds:

- rounds - maximum 100
- points per round - maximum 200
- sets per point within each round - maximum 10

Even though the maximum limits set in the General Survey software are generous, the limit on how many points you can observe depends on the memory available on the controller. For example, you could measure 100 rounds to 10 points, or 10 rounds to 200 points, but memory limits preclude measuring 100 rounds to 200 points.

For more details see:

[Standard deviations screen](#)

[Point - Residuals screen](#)

[Point details screen](#)

[FineLock](#)

[Face order](#)

[Observation order](#)

[Sets per point](#)

[Number of rounds](#)

[Skipping observations](#)

[Automated rounds](#)

[Monitoring](#)

Standard deviations screen

At the end of each round, the *Standard deviations* screen appears. This screen shows the standard deviations of each point in the rounds list.

Do one of the following:

- To observe another round, tap *+ Round*.
- To store the current rounds session, tap *Close*.
- To view/edit the Details of a point, highlight the point and then tap *Details*.
- To view or edit the residuals of each individual observation to a point, tap the point in the list once.
- If you have enabled a measured point to be added to a CSV file, select the *Add to CSV file* option. The point will be stored in the displayed file name. To enable adding a file, see: [Add to CSV file](#).
- To exit from rounds and delete all rounds observations, tap *Esc*.

Notes

- *Each individual round is stored to the job only when you tap Close or + Round to exit the Standard deviations screen.*
- *To change the rounds configuration settings, tap Options.*

Tips

- To highlight an item in a list, tap and hold the item for at least half a second.
- To sort a column in ascending or descending order, tap the column header. Tap the *Point* column header to sort the point in ascending or descending observed order.
- To change the residual display view, select an option from the drop-down list in the *Residuals* screen.

Point – Residuals screen

The *Point residuals* screen shows the differences between the mean observed position and the individual observations to a particular point.

Do one of the following:

- To disable an observation, highlight it and then tap *Use*.
- To view the details of an observation, highlight it and then tap *Details*.
- To return to the *Standard deviations* screen, tap *Back*.

Notes

- *If you have measured face 1 and face 2 observations to a point, when you disable the observation for one face, the corresponding observation on the opposite face is automatically disabled.*
- *Whenever you make a change in the Point residuals screen, the mean observations, residuals, and standard deviations are recalculated.*
- *If the current station setup has a single backsight only, the Use softkey is not available for observations to the backsight. Observations to the backsight are used to orientate observations and cannot be deleted.*
- *If you remove observations, the  icon appears. If you skipped observations in a round, no icon appears.*

Tip - If the residuals for an observation are high, it may be better to disable the observation from the round.

Point details screen

The *Point details* screen shows the mean observation details for a particular point.

Remote object

In a conventional survey, if the instrument does not support DR mode, or if you cannot measure a distance, use this method to calculate the height and/or width of a remote object. See the following diagram.

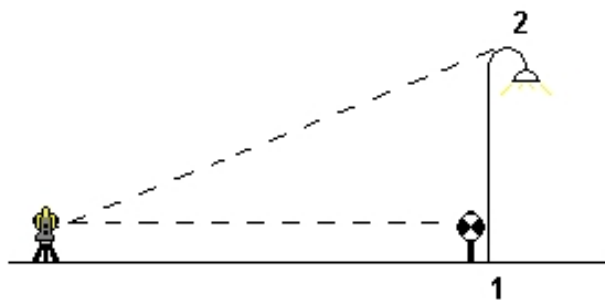

1. Start a conventional survey.
2. Select *Measure / Measure Topo / Remote object*.
3. Measure an angle and distance to the bottom of the remote object (1).
4. Set the method as required.
5. Sight to the Remote point (2).
6. Tap *Store* to store the observation.
7. To make multiple remote object observations, repeat steps 5 and 6.

Using the first measurement and continuous HA VA angles, General Survey calculates the position of the remote object, showing the width and elevation difference from the base point. The observation to the base of the remote object is stored as an HA, VA, SD. The Remote point is stored as an HA, VA with a computed SD, including the Object height and Object width.

Scanning

3D scanning is an automated direct reflex (DR) measuring process that digitally captures the shape of physical objects you have defined using a laser of light. 3D laser scanners create **point clouds** of data from the surface of an object.

The *Scanning* option is only available when connected to a total station that has Trimble VISION technology. Use *Surface scan* when connected to a Trimble S Series total station that does not have VISION technology.

Scanning is available with USB, 2.4 GHz Cirronet radio and Bluetooth connections to the controller.

To access the *Scanning* screen, from the *Measure* menu tap *Scanning*. The options available in the *Scanning* screen depend on the connected instrument.

For more details, see:

[Scan methods](#)

[Framing methods](#)

[Scan points](#)

[Scan parameters](#)

[Scanning modes](#)

[Panorama images](#)

[Progress information](#)

[Ending a scan](#)

Scan methods

Perform a scan using one of the following methods:

Use the method...	To...
HA VA interval	Scan complex surfaces when you cannot use a plane to approximate the surface you are scanning.
Vertical plane	Use Trimble SureScan™ technology to scan plane surfaces where you need a regular grid interval.
Horizontal plane	
Tilted plane	
Line and offset	Scan from a center line that has offsets to the left and/or right. General Survey defines the surface using horizontal offsets perpendicular to the center line.

Notes

- Scan time is increased if there are areas within the scan that will not return an EDM signal. Where possible, try to minimize blank space in the scan area.
- When you perform a scan using a robotic connection, Trimble recommends that you stay within the range of the radio link to ensure that all necessary data is collected successfully. If you lose the radio link, the remainder of the current scan line is skipped.
- You can scan a full 360° horizontally and vertically down to 130° (144 gon).
- Make sure that the DR maximum distance configured in Instrument / EDM settings is set high enough to achieve the required scanning range.

Framing methods









The framing method options depend on the scan method selected. The possible options are:

Framing method	Description
Rectangle	Tap on the video screen to define the first corner and then the opposite corner of the scan rectangle. Tap and drag the rectangle to resize it.
Polygon	Tap on the video screen to define each vertex of the polygon scan area. Tap and drag the last vertex to move it.
Horizontal band	Tap on the video screen to define the upper and lower vertical edges of the full 360° horizontal band.
Plane	For each point on the plane, aim to the point and then tap on the video screen to define the point.

Note – The camera is not coaxial with the telescope. For accurate framing at close range, enter the approximate distance from the instrument to the object being scanned in the *At distance field* and then define the scan frame. Entering the correct distance helps to draw the scanning frame in the correct position and enables the software to correct for the offset between the camera and the telescope. Alternatively, have the instrument in DR and TRK mode when framing.

Navigating the video screen

You can navigate/zoom around the video frame in the scanning window. The navigation controls are as follows.

Button / Softkey	Function
	Zoom in/out to the maximum zoom level/full extents.
	Zoom in/out one zoom level at a time.
	
	Tap Fill region to fill the framing region with shading to improve contrast against the video screen.
	Tap Image settings to define image settings. See Camera options .
	Tap Define region and follow the prompts on screen to tap on the screen and define the region to scan.
	Tap Pan and then tap an area of the map to center on, or tap and drag the video area to where you want to reposition the image.
	Tap Reset region to clear the framing region.
	Tap Undo to undo the remove points from the Video screen.
Options	<i>Display point clouds</i> controls the option to display the point cloud over the scan.
	<i>Color</i> controls the color of the point cloud.
	<i>Point size</i> controls the width of the pixel displayed in the point cloud.

Point cloud color

Select	To...
Cloud color	Show all points the same color
Station color	Indicate the station used to measure the points
Scan color	Indicate the scan the points belong to
Grey scale intensity	Indicate the reflective intensity of points using a grey scale
Color coded intensity	Indicate the reflective intensity of points using color coding

Scan points

When scanning, set up the instrument so that you have a good view of the plane or line you are scanning. For example, when scanning a horizontal plane, set up the instrument as high as possible overlooking the plane. For a vertical plane, the instrument should be set up as close as perpendicular to the plane as possible.

When measuring or selecting scan points, choose points that are reasonably spaced and provide a good spread. For example, when scanning a vertical plane, choosing points that are in diagonally opposing corners of the plane provides the best geometry.

Scan parameters

The scan parameter options depend on the scan method selected.

Note - The time to complete a scan is an estimate only. Actual scan times will vary depending on the surface or object being scanned.

For the method...	Select one of the following options and then enter the appropriate value (s)
HA VA interval	<ul style="list-style-type: none"> • Horizontal and vertical distance intervals • Horizontal and vertical angle intervals • Total number of points in the scan • Total time <p>Note – Defining the scanning grid through distance intervals assumes that the scanning object is a constant distance from the instrument. In other cases, the scan points will not constitute an even grid.</p>
Vertical plane	<ul style="list-style-type: none"> • Grid interval • Total number of points in the scan
Horizontal plane	<ul style="list-style-type: none"> • Total time <p>Note – The defined scan area may not exactly fit the grid interval. There may be an area left over along the scan extents that is smaller than the grid interval. If the width of this area is less than one-fifth of the grid interval, the points along this scan area will not be measured. If the width is more than one-fifth of the grid interval, then an extra point is scanned</p>
Tilted plane	
Line and offset	<ul style="list-style-type: none"> • Interval, entering the left and right <i>Offset</i> values, the <i>Offset interval</i>, and the <i>Station interval</i> • Total number of points in the scan • Total time

Scanning modes

Available *Scanning modes* depend on the connected instrument:

- *High speed* scans up to 15 points per second to a maximum range of about 150 m.
- *Long range (TRK)* scans with the EDM in TRK mode and scans up to 2 points per second to a maximum range of about 300 m.
- *Long range (STD)* scans with the EDM in STD mode and scans up to 1 point per second to a maximum range of about 300 m.

Notes

- *Higher speed scans can result in more skipped points. Select a scanning mode appropriate to the object you are scanning.*
- *When using long range scanning mode, intensity information is not available and is not saved to the TSF file.*

Panorama images

To capture a panorama image with the scan, select the *Panorama* check box and then tap *Next* and specify the settings for the panorama image. See [Panorama](#).

Progress information

During a scan, the following progress information appears in the scanning window:

- The number of panorama images captured.
- The percentage of scan completed.
- The number of points scanned.
- The estimated time remaining. This is updated as the scan progresses to reflect the current scan speed and is dependent on the surface of the object in the scan.

While a scan is in progress:

- Other conventional instrument/survey functions are disabled. If you need to access a conventional survey or instrument function during a scan, you must pause the scan, perform the operation and then continue the scan.
- You cannot access the video window.

Ending a scan

When the scan is complete, the instrument returns to its original position.

To cancel a scan that is in progress, tap *Esc* and then tap *Yes*. The scanning record and associated TSF file will still be written if you manually cancel a scan.

To export scan data, from the *Jobs* menu tap *Import / Export* and then tap *Export fixed format*. Select *Comma delimited* in the *File format* field and then tap *Accept*. In the *Select points* screen, select *Scan file points*. A message confirms the export is complete. Tap *OK*.

Notes

- When the scan is complete, the name of the scan file and the scan properties are stored in the job file.
- Scanned points are not stored in the job file; they are written to a TSF file that is saved to the **<jobname> Files** folder.
- If a scan contains over 100,000 points, the points will not appear in the map or in point manager.
- You can import the JOB or JXL file into the Trimble Business Center or Trimble RealWorks Survey software. Associated TSF and JPEG files stored in the **<jobname> Files** folder are imported at the same time.
- When creating DC files, either on the controller or when downloading the file with office software such as Trimble Geomatics Office or the Trimble Data Transfer utility, the data from the TSF file(s) associated with the job is inserted into the DC file as regular conventional observations.
- To transfer JPEG files from the Trimble CU in the docking station to the office computer, use the USB-to-Hirose cable. You cannot use the DB9-to-Hirose serial cable to transfer JPEG files.

Surface scan

3D scanning is an automated direct reflex (DR) measuring process that digitally captures the shape of physical objects you have defined using a laser of light.

The *Surface scan* option is only available when connected to a Trimble S Series total station. Use *Scanning* when connected to an instrument that has Trimble VISION technology.

Performing a surface scan using General Survey

1. From the *Survey* menu, select *Surface scan*.
2. Enter the *Start point name* and *code* (if necessary).
3. In the *Method* field, select a measurement method.
4. Define the area for the scan and grid interval.
5. Tap the instrument icon to access Instrument functions and set the EDM measurement method (TRK is fastest).

The total number of points to scan, scan grid dimensions, and estimated scan time are displayed. Change the scan size, step sizes or EDM measurement method to increase or decrease the number of points and scan time.

6. Tap *Start*.

Defining the scan area

To define the scan area, do one of the following:

- If the point already exists, enter the point name, or use menu arrow to select it from the list.
- From the pop-up menu in the *Top left* and *Bottom right* fields select *Fast fix* or *Measure* to measure and store points that define the limits of the search.

Define the scan area with one of the following methods:

- HA VA interval
- Rectangular plane
- Line and offset

HA VA interval

Use this method on complex surfaces when you cannot use a rectangular plane to approximate the surface you are scanning.

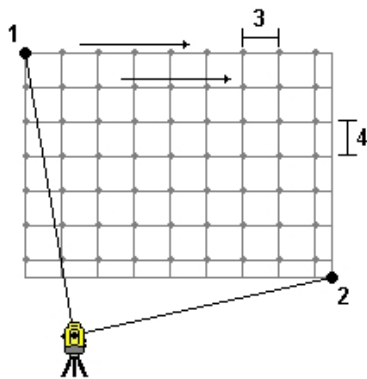

1. Aim to the top left corner of the scan area (1) and measure a point.
2. Aim to the bottom right corner of the scan area (2) and measure another point.
3. Define the angular grid interval, where:
 - 3 is the Horizontal angle
 - 4 is the Vertical angle

Tip - To define a Horizontal only scan of a 360° scan area, set the Top left and Bottom right points to the same name, and set the VA interval to null.

Rectangular plane

Use this method on a plane surface where you need a regular grid interval. General Survey determines the angle of the plane, and uses this and the grid interval to approximate how far to turn the instrument for each subsequent point.

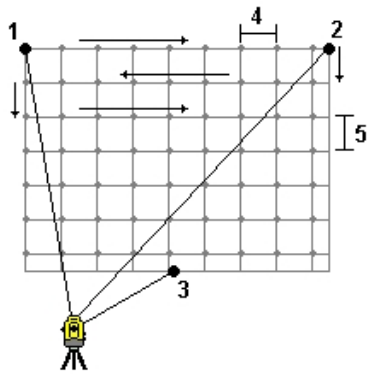

1. Aim to the first corner of the scan area (1) and measure a point.
2. Aim to the second corner of the scan area (2) and measure another point.
3. Aim to the third point on the opposite side of the plane (3) and measure a point.
4. Define the distance grid interval, where:
 - 4 is the horizontal distance
 - 5 is the vertical distance

Line and offset

Use this method to define the area to scan from a center line that has equal offsets to the left and right. General Survey defines the surface using horizontal offsets perpendicular to the center line. The software then uses this definition and the station interval to determine approximately how far to turn the instrument for each subsequent point.

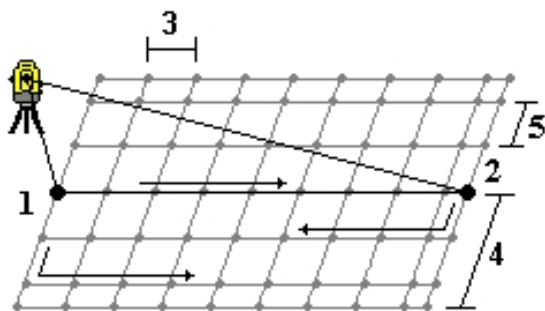

1. Do one of the following:
 - Two point method:
 - a. Aim to the start point of the center line (1) and measure a point.
 - b. Aim to the end point of the center line (2) and measure another point. These two points (1 and 2) define the center line.

- Access the pop-up menu in the *Start point* field. Change the method and then define the line by a start point with azimuth and length.
2. Define the station interval (3).
 3. Define the maximum offset distance (4).
 4. Define the offset interval (5).

General Survey scans the center line first, then the points on the right-hand side, and finally the left-hand side.

Note - With all of the above methods, the defined scan area may not exactly fit the grid interval. There may be an area left over along the scan extents that is smaller than the grid interval. If the width of this area is less than one-fifth of the grid interval, the points along this scan area will not be measured. If the width is more than one-fifth of the grid interval, then an extra point is scanned.

Panorama

In a conventional survey using an instrument that has VISION technology, use the *Panorama* measurement method to capture a panorama image without performing a scan.

Note - To capture a panorama image with a scan, see [Scanning](#).

1. Connect to the instrument.
2. From the *Measure* menu, select *Panorama*.
3. Define the area for the scan. See [Scanning](#).
4. Configure settings for the panorama image(s). The available settings depend on the connected instrument.

Setting	Function
<i>Image size</i>	The image captured is always the same as the video display on screen. Not all image sizes are available at all zoom levels. Use the navigation controls in the video screen to change the zoom level.
<i>Compression</i>	The higher the quality of the image, the larger the file size of the captured image.
<i>Fixed exposure</i>	Fixes the exposure to the settings at the time you tap <i>Start</i> . When using the <i>Panorama</i> function with <i>Fixed exposure</i> enabled, point the instrument toward the location that defines the camera exposure that you want used for all panoramic images before you tap <i>Start</i> . Note - The exposure settings for the camera affect the exposure used by still images/panoramas as well as video. To access these settings, from the <i>Instruments</i> menu tap <i>Video / Camera options</i> .
<i>Fixed contrast</i>	If available, select this check box to adjust each image to the best contrast and white balance. When using the <i>Panorama</i> function with <i>Fixed contrast</i> enabled, point the

Setting	Function
	<p>instrument toward the location that provides the best contrast before you tap <i>Start</i>. If a high contrast area is not available (for example, you want to point the instrument at a low contrast white wall), Trimble recommends clearing the <i>Fixed contrast</i> check box.</p> <p>The <i>Fixed contrast</i> setting is independent of the <i>Fixed exposure</i> setting. Trimble recommends the following:</p> <ul style="list-style-type: none"> • For the best contrast and good blending between adjacent images, enable HDR if it is available, and disable the <i>Fixed exposure</i> and <i>Fixed contrast</i> check boxes. • If HDR is not available: <ul style="list-style-type: none"> • For good contrast but poorer blending between adjacent images, enable the <i>Fixed exposure</i> check box and disable the <i>Fixed contrast</i> check box. • For good blending between adjacent images but less contrast, enable both the <i>Fixed exposure</i> and <i>Fixed contrast</i> check boxes.
<i>High dynamic range (HDR)</i>	<p>If available, enables HDR imaging.</p> <p>With HDR turned on, the instrument captures three images rather than one image, each with different exposure settings. During HDR processing in Trimble Business Center, the three images are combined to produce a composite image that has better tonal range to show more detail than any of the individual images.</p> <p>For best results, Trimble recommends disabling the <i>Fixed exposure</i> and <i>Fixed contrast</i> check boxes when HDR is enabled.</p>
<i>Image overlap</i>	Enter the amount the images should overlap. A higher overlap results in more tie points.

5. Tap *Start* to begin taking the images.
6. Tap *Finish* when all images have been captured.

Panorama images are saved to the <jobname> **Files** folder.

Check point

In a conventional survey, tap *Check* to measure a check class point.

To measure a check point:

1. In the *Point name* field, enter the name of the point to check.
2. In the *Method* field, select a measurement method and enter the required information in the fields that appear.
3. In the *Target height* field, enter the height of the target and then tap *Measure*.

When measuring to the bottom notch on a [Trimble prism base](#), tap the advanced pop-up arrow () and then select *Bottom notch*.

If you did not select the *View before storage* check box, the point is stored with a classification of *Check*. If you selected the *View before storage* check box, the check shot deltas appear on the *Check shot* screen.

When you observe the point, if the station setup is the same as when you originally measured the point, the deltas are the difference in values between the original observation and the check observation. The deltas displayed are horizontal angle, vertical distance, horizontal distance, and slope distance.

If the station setup is different from when you originally measured the point, the deltas are in terms of the best coordinates from the original point to the check point. The deltas displayed are azimuth, vertical distance, horizontal distance, and slope distance.

4. Tap *Enter* to store the check point. Tap *Esc* to abandon the measurement.

Tap *Chk BS* to display the *Check backsight* screen. This is similar to the *Check point* screen, but the *Point name* field shows the backsight of the current station setup. You cannot edit this field.

To observe a check shot to the backsight, use the same procedure as described above.

To return to the *Check point* screen, tap *Chk topo*.

Tip - During a conventional survey, you can use the tap and hold menu in the map to quickly measure a check point. If there are no points selected, *Check backsight* is available; if one point is selected *Check shot* is available. Alternatively, to measure a check shot from any screen, press [CTRL + K] on the controller.

Fast fix

Tap *Fast fix* to quickly measure and automatically store a construction point. Alternatively, select *Fast fix* from the pop-up menu in the *Point name* field.

Note - In a conventional survey, *Fast fix* uses the current measurement mode. If you need more flexibility, select *Measure* from the pop-up menu in the *Point name* field.

Typically, a construction point is used in *Cogo - compute points* or *Key in - lines and arcs*.

Construction points are stored in the General Survey database with autopoint names that increment from Temp0000. They are classified higher than check points and lower than normal points. For more information, see [Database Search Rules](#).

To view construction points in a map or list, select them from the *Select filter* list. To view the *Select filter* list, in the :

- 2D map, tap the up arrow to access more softkeys and then tap *Filter*.
- 3D map, tap  and then select *Filter*.

Survey – Calibration

Calibration

A calibration calculates parameters for transforming WGS-84 coordinates into local grid coordinates (NEE). It either calculates a [horizontal](#) and [vertical](#) adjustment, or a transverse mercator projection and a 3-parameter datum transformation, depending on what has already been defined.

For accurate calibration, your site should be within at least four control points with known 3-D grid coordinates.

WARNING - You must complete a calibration **before** you compute offset or intersection points, or stake out points. If you change the calibration after computing or staking out these points, they will not be consistent with the new coordinate system and any points computed or staked out after the change.

To calibrate point coordinates:

1. Enter the grid coordinates of your control points. Key these in, transfer them from your office computer, or measure them using a conventional total station.
2. Measure the points with GNSS.
3. Perform either an [automatic](#) or a [manual](#) calibration.
4. To obtain the current list of points being used in the calibration, select *Measure / Site calibration*.

Notes and recommendations

- You can perform a calibration using one of the real-time GNSS survey styles in the General Survey software. Do this manually, or let the General Survey software do it automatically. If all the points have been measured, you do not need to connect the Trimble controller to a receiver during a manual calibration.
- Multiple calibrations can be performed in one job. The last calibration performed and applied is used to convert the coordinates of all previously surveyed points in the database.
- You can use up to 20 points for a calibration. Trimble strongly recommends that you use a minimum of four 3D local grid coordinates (N, E, E) and four observed WGS84 coordinates, with the local projection and datum transformation parameters (the coordinate system). This should provide enough redundancy.
- You can use a combination of 1D, 2D, and 3D local grid coordinates. If no projection and no datum transformation are defined, you must have at least one 2D grid point.

- If you did not specify the coordinate system, the General Survey software calculates a Transverse Mercator projection and a three-parameter datum transformation.
- Use the Trimble Business Center software, Trimble Data Transfer utility, or Windows Mobile Device Center to transfer control points.
- Be careful when naming points that are to be used in a calibration. Before you begin, familiarize yourself with the [Database search rules](#).
- The set of WGS-84 coordinates must be independent of the set of grid coordinates.
- You select the grid coordinates. Select the vertical coordinates (elevation), the horizontal coordinates (northing and easting values), or all of these together.
- Place the calibration points around the perimeter of the site. Do not survey outside of the area enclosed by the calibration points, as the calibration is not valid beyond this perimeter.
- The origin of the horizontal adjustment is the first point in the calibration when using one or two calibration point pairs. When there are more than two calibration point pairs, the computed centroid position is used for the origin.
- The origin of the vertical adjustment is the first point in the calibration with an elevation.
- When reviewing a calibration point in the database, notice that the WGS84 values are the **measured** coordinates. The grid values are derived from these, using the current calibration. The original keyed-in coordinates remain unchanged. (They are stored elsewhere in the database as a point with the *Type* field showing *Keyed in coordinates* and the *Stored as* field showing *Grid*.)
- When you are calibrating a no projection, no datum job, (where ground coordinates are required after calibration) you must define the project height (average site height). When the job is calibrated, the project height is used to compute a ground scale factor for the projection, using the inverse of the ellipsoid correction.
- When you start a Scale Factor Only job and then introduce GNSS data, you must perform a site calibration to relate the GNSS data to the Scale Factor Only point coordinates.
When you select *Site Calibration*, you must specify whether the Scale Factor Only coordinates in the job represent grid coordinates or ground coordinates. The site calibration computations then set up a grid coordinate system or a ground-based coordinate system, that best fits the existing data in the job to the GNSS data.

Configuring the survey style for a site calibration

A calibration calculates parameters for transforming WGS-84 coordinates into local grid coordinates (NEE). Set the parameters for computing a calibration when you create or edit a survey style.

To set the parameters for computing a calibration:

1. From the Trimble Access menu, tap *Settings / Survey styles / <Style name>*.
2. Tap *Site calibration*.
3. The *Fix H. scale field to 1.0*: check box details whether the calibration computation should compute a horizontal scale factor or not:

- To compute the horizontal scale factor, make sure the check box is clear. (This is the default setting.) Use this option only if GNSS measurements need to be scaled to fit the local control. (GNSS measurements are usually more precise.)
 - To fix the horizontal scale factor to 1.0, select the check box. Select the check box to avoid distorting the geometry of the GNSS network, but note that the calibration residuals will be higher.
4. For the General Survey software to automatically perform a calibration when you measure a calibration point, select the *Auto calibrate* check box. To switch automatic calibration off, clear the check box.
 5. Select the vertical adjustment type to be computed and applied:
 - The *Constant adjustment only* option will compute a vertical shift value to best fit the calibration point measured elevations to the control elevations.
 - The *Inclined plane* option will compute a vertical shift plus north and east inclinations to best fit the calibration point measured elevations to the control elevations. Typically, the Inclined plane method will result in smaller vertical residuals than the Constant adjustment only method.
 6. Select an observation type appropriate to a calibration point. The options for a calibration point are topo point or observed control point.

Note - If you set the observation type to *Topo point*, all settings are defined in the survey style for a *Topo point*.
 7. If necessary, set the tolerances for maximum horizontal and vertical residuals, and maximum and minimum horizontal scale settings. These settings only apply to automatic calibration and do not affect manual calibration.

You can also specify the maximum slope of the vertical adjustment plane. The General Survey software warns you if the slope in the north direction or the slope in the east direction exceeds this. Generally the default settings are appropriate.
 8. Specify how the calibration points you measure will be named:
 - In the *Method* field, choose one of the following options: *Add prefix*, *Add suffix*, or *Add constant*.
 - In the *Add* field, enter the prefix, suffix, or constant.

The table below shows the different options and gives an example of each.

Option	What the software does	Example value in the Add field	Grid point name	Calibration point name
Same	Gives the calibration point the same name as the grid point	-	100	100
Add prefix	Inserts a prefix before the grid point name	GNSS_	100	GNSS_100
Add suffix	Inserts a suffix after the grid point name	_GNSS	100	100_GNSS
Add constant	Adds a value to the grid point name	10	100	110

For more information, see:

[Calibration](#)

[Automatic calibration](#)

[Manual calibration](#)

Manual calibration

Key in the grid coordinates of your control points. Alternatively, transfer them from your office computer, or use a conventional instrument to measure them. Then measure the points with GNSS.

Performing a manual site calibration

1. From the main menu, select *Measure / Site calibration*.
2. For *Scale factor only* jobs:
 - If the job uses ground coordinates, select *Ground*.
 - If the job uses grid coordinates, select *Grid*.
3. Use *Add* to add a point to the calibration.
4. Enter the name of the grid point and the WGS-84 point in the appropriate fields.
The two point names do not have to be the same, but they should correspond to the same physical point.
5. Change the *Use* field as required and tap *Accept*.
The calibration residuals screen appears.
6. Tap *Results* to see the horizontal and vertical shifts that the calibration has calculated.
7. To add more points, tap *Esc* to return to the calibration screen.
8. Repeat steps 3 through 6 until all the points are added.
9. Do one of the following:
 - If the residuals are acceptable, tap *Apply* to store the calibration.
 - If the residuals are not acceptable, recalculate the calibration.

Recalculating a calibration

Recalculate a calibration if the residuals are not acceptable, or if you want to add or remove points.

1. From the main menu, select *Measure / Site calibration*.
2. Do one of the following:
 - To remove (exclude) a point, highlight the point name and then tap *Remove*.
 - To add a point, tap *Add*.
 - To change the components used for a point, highlight the point name and tap *Edit*. In the *Use* field, choose whether to use the vertical coordinate of the grid point, the horizontal

coordinates, or both horizontal and vertical coordinates.

3. Tap *Apply* to apply the new calibration.

Note - Each calibration calculation is independent of the previous one. When a new calibration is applied, it overwrites any previously calculated calibration.

Automatic calibration

When you use this function to measure calibration points, the calibration calculations are performed and stored automatically.

Define a projection and datum transformation. Otherwise, a transverse mercator projection will be used and the datum will be WGS-84.

Performing an automatic site calibration

1. Set your automatic calibration settings in the *Site calibration* screen.
 - a. To view the *Site calibration* screen, do one of the following:
 - From the Trimble Access menu, tap *Settings / Survey styles* and select your survey style. Tap *Site calibration*.
 - When you measure a calibration point, tap *Options*.
 - b. Select the *Auto calibrate* check box to display calibration residuals only if the calibration tolerances are exceeded.
 - c. Configure the naming relationship between the grid and WGS-84 points.
 - d. Tap *Accept*.

2. Enter the grid coordinates of your Calibration points. Key these in, transfer them from your office computer, or measure them using a conventional total station.

For keyed in coordinates check that the coordinate fields are *North*, *East*, and *Elevation*. If they are not, tap *Options* and change the *Coordinate view* to *Grid*. Key in the known grid coordinates and tap *Enter*.

Select the *Control point* check box. (This ensures that the point is not overwritten by a measured point.)

For transferred coordinates make sure that these coordinates are:

- transferred as grid coordinates (N, E, E), not as WGS84 coordinates (L, L, H)
- control class points

3. Measure each point as a Calibration point.

- a. In the *Method* field, select *Calibration point*.
- b. Enter the grid point name. The General Survey software names the GNSS point automatically, using the naming relationship that you configured earlier.

Once the point has been measured, the Auto-calibrate function matches the points (grid and WGS-84 values), and calculates and stores the calibration. The calibration is applied to all previously measured points in the database.

4. When you measure the next Calibration point, a new calibration is calculated using all of the Calibration points. It is stored and applied to all previously measured points.

When one point has been calibrated, or a projection and datum transformation have been defined, the *Find* softkey appears. You can use this to navigate to the next point.

If the calibration residuals are exceeded, consider removing the point with the most extreme residuals. Do one of the following:

- If at least four points are left after removing that point, recalibrate using the remaining points.
- If not enough points are left after removing that point, measure it again and recalibrate.

It may be necessary to remove (re-measure) more than one point. To remove a point from the calibration calculations:

1. Highlight the point name and tap *Enter*.
2. In the *Use* field, select *Off* and tap *Enter*. The calibration is recalculated and the new residuals are displayed.
3. Tap *Apply* to accept the calibration.

To view the results of an automatic calibration:

1. From the *Measure* menu, select *Site calibration*. The *Site calibration* screen appears.
2. Tap *Results* to see the *Calibration results*.

To change a calibration that has been calculated using the *Auto calibrate* function, select *Site calibration* from the *Measure* menu. Then proceed as described in [Manual calibration](#).

GNSS Survey – Setup

GNSS survey – Getting started

The process for completing measurements using a GNSS receiver is described below. Select each link to view more information.

1. [Configure your survey style](#)
2. [Set up the base receiver equipment](#) (if required)
3. [Set up the rover receiver equipment](#)
4. [Start the survey](#)
5. [Measure points](#)
6. [End the survey](#)

Note - If you need to convert WGS-84 coordinates into local grid coordinates (NEE), then you must perform a [site calibration](#) before performing the above steps.

Configuring GNSS survey styles

All surveys in General Survey are controlled by a Survey Style. Survey Styles define the parameters for configuring and communicating with your instruments, and for measuring and storing points. This whole set of information is stored as a template and used each time you start a survey.

Note - General Survey uses the settings from the selected survey style when you start the survey. General Survey will check the style settings to ensure that they are appropriately configured for the equipment that you are connected to. For example, if GLONASS is enabled in the survey style it will check if the GNSS receiver or antenna you are connected to also supports GLONASS. If General Survey detects an incorrect setting, or if it detects that the settings in the survey style have never been checked, it will ask the user to confirm or correct the settings. Any changed settings are saved to the survey style.'

The GNSS survey type you use will depend on available equipment, field conditions, and the results required.

The General Survey software provides a **Real-Time Kinematic** survey style. Real-time kinematic surveys use a [data link](#) to send observations or corrections from the base station to the rover. The rover then calculates its position in real time.

To use one of the following survey types, you must create your own survey style:

- **FastStatic** - a postprocessed survey using occupations of up to 20 minutes to collect raw GNSS data. The data is postprocessed to achieve sub-centimeter precisions.
- **Postprocessed Kinematic** - postprocessed kinematic surveys store raw stop-and-go and continuous observations. The data is postprocessed to achieve centimeter-level precisions.
- **Real-Time Kinematic and Infill** - allows you to continue a kinematic survey when radio contact with the base station is lost. The infill data must be postprocessed.
- **Real-Time Kinematic and Data Logging** - records raw GNSS data during an RTK survey. The raw data can be postprocessed later, if required.
- **Real-Time Differential Survey** - uses the differential corrections transmitted from a land-based receiver or from SBAS or OmniSTAR satellites to achieve sub-meter positioning at the rover.

To configure a survey style:

1. From the Trimble Access menu, tap *Settings / Survey styles*.
2. Do one of the following:
 - To edit an existing survey style, tap *<Style name>* and then tap *Edit*.
 - Tap *New*. Enter a name for the style and then tap *Accept*.
3. Select each of the options in turn, and set them to suit your equipment and survey preferences.

To configure...	See...
the rover receiver	Rover and base options
the base receiver	Rover and base options
data link settings	Data link options
the parameters for measurement methods	Measurement method options
PP initialization times	PP initialization times
stakeout settings	Stakeout options
settings for a laser rangefinder	Configuring the survey style to use a laser rangefinder
settings for an echo sounder	Echo sounder instruments
settings for outputting NMEA messages	NMEA outputs
the tolerance for a duplicate point warning	Duplicate point tolerance

4. Once you configure all the settings, tap *Store* to save them, and then tap *Esc* to return to the main menu.

Rover and base options

The fields available in the *Rover options* and *Base options* screens are similar for all GNSS survey types. The survey types that enable postprocessing have additional fields for specifying the logging device, logging interval, and the filename formats for files. All fields that appear in the *Rover options* and *Base options* screens for any GNSS survey type are described below.

Note - The *Base options* screen is not available if you have set the *Broadcast format* to FKP, VRS, Multi station, RTCM3Net, or RTX for the RTK survey type, or if you have set the *Broadcast format* to SBAS or OmniSTAR for the RT Differential survey type in the *Rover options* screen.

For information on setting up your rover receiver equipment, see [Setting up the equipment for a rover receiver](#).

Survey type

Select the type of survey you want to use. For a description of the types available, see [Configure the survey style](#). The rest of the fields in the screen update to reflect the survey type selected.

Generally, when a GNSS surveying system setup consists of one base and one rover receiver, make sure that the survey type selected in the *Rover options* field and the *Base options* field is the same. However, when there are multiple rovers, you can have various configurations but make sure that if the rover is logging raw data your base station is also logging raw data.

Broadcast format

The rover selection should always correspond to the broadcast message format generated by the base.

- For real-time kinematic surveys, the format of the broadcast message can be CMR, CMR+, CMRx, or RTCM RTK.

The default is CMRx, which is a format used by the modern Trimble receivers. It is a compressed data format designed to handle the extra load of additional GNSS signals from modernized GPS, GLONASS, Galileo, QZSS, and BeiDou. Only use CMRx if all receivers have the CMRx option installed. To check if this option is installed in the receiver, select *Instrument / Receiver settings* on the controller that is connected to the receiver.

Note - If you want to operate several base stations on one frequency, use CMR+ or CMRx. For more information, see [Operating several base stations on one radio frequency](#).

- For [wide-area](#) RTK surveys, the broadcast message format can be from the following wide-area RTK solutions: FKP (RTCM), VRS (CMR), VRS (RTCM), and RTCM3Net.
- Networked single base RTK is also supported in the form of "Multi station" surveys with both CMR and RTCM formats. These surveys enable you to connect to a network service provider by cellular modem or through the Internet, and receive CMR or RTCM data from the nearest physical reference station in the network.
- For RTX surveys, the *Survey type* must be *RTK* and the *Broadcast format* must be *RTX (SV)* or *RTX (Internet)*. For more information, see [RTX](#).
- For RT differential surveys, the *Broadcast format* must be *RTCM* for land-based transmissions. For satellite-based transmissions, select [SBAS](#) or [OmniSTAR](#).

Use station index

If you want to use multiple base stations on one radio frequency, enter the station index number that you want to use first in the *Use station index* field.

If you do not want to use multiple base stations on one frequency, enter the same station index number that you enter in the *Base options* screen.

To use any base station operating on the frequency set in the rover radio, tap *Any*.

WARNING - If you tap *Any* and there are other base stations operating on the frequency, your rover survey could receive corrections from the wrong base.

For information about using multiple bases, see [Operating several base stations on one radio frequency](#).

Prompt station index

When you use a receiver that supports multiple base stations on one radio frequency, the General Survey software asks you to specify the base to use when you start the rover survey. You can stop this question from appearing by clearing the *Prompt for station index* check box. The station index number in the *Use station index* field is used.

In a GNSS survey style, you can set the *Station index* for the base receiver to a number between 0 and 31, and you can set the *Use station index* for the rover receiver to *Any* or to the same number that the base is transmitting. When the rover station index is set to *Any*, the rover receiver will accept base data from any base. If you set the rover station index to match the same number as the base station index, the rover will accept data only from a base with the same station index.

The base station index number is automatically generated according to the controller serial number. Newer controllers do not all default to the same number, and so fewer base receivers will transmit the same station index, which means there is less chance that you accidentally receive corrections from the wrong base.

The rover station default index value is *Any*. If you know your base station index, and you want to connect to only that base, make sure that you set the appropriate station index for the rover.

If the *Prompt for station* check box is selected, a list of base stations on your radio frequency appears when you start the survey.

Satellite differential

When the radio link is down in a real-time survey, the receiver can track and use signals from [SBAS](#) or [OmniSTAR](#).

Logging device

With survey types that involve postprocessing, set the *Logging device* to be either the receiver or controller.

Note - The *Geo7X* and *GeoXR* controllers always log to the controller.

Logging interval

To define the logging interval, enter a value in the *Logging interval* field. The base and rover logging intervals must correspond to (or be multiples of) each other.

When using an RTK and Infill survey type, the *Logging interval* is for the infill session only.

When using an RTK and Data logging survey type, the *Logging interval* should be the same for each receiver - typically 5 seconds. The *RTK interval* remains at 1 second.

Auto file names

To define the logging file name, clear the *Auto file names* check box and then enter the file name in the *Logging file name* field.

Log data in RTK mode

Select this option to log raw data in the RTK part of an *RTK & infill* survey type. Use this option if you want postprocessed data stored as a backup to your RTK survey. When this option is selected, switching between Infill and RTK modes does not suspend logging.

Elevation mask

You must define an elevation mask below which satellites are not considered. For kinematic applications, the default of 10° is ideal for both the base and rover.

For differential surveys where the base and rover are separated by more than 100 kilometers, Trimble recommends that the base elevation mask be lower than the rover setting by 1° per 100 kilometers of separation between the base and rover. Generally, the base elevation mask should be no lower than 10°.

PDOP mask

Define a PDOP mask for the rover. When the satellite geometry goes above the set PDOP mask, the General Survey software issues high PDOP warnings, pauses the time to initialize counter (PPK surveys), and suspends the measurement of a FastStatic point. Initialization and measurement resumes when the PDOP drops below the mask. The default value is 6.

Antenna settings

To define the antenna details, select the correct antenna from the list of antennas and select the correct measurement method for the equipment and type of survey.

To set the default antenna height, enter a value in the *Antenna height* field.

The *Part number* field automatically displays the part number.

Enter the serial number.

GNSS signal tracking

GNSS signals tracked by the rover receiver must also be tracked by the base receiver.

Notes

- *If you enable tracking of satellite signals that are not being tracked by the base or contained in the RTK messages coming from the base, then those signals will not be used in RTK at the rover. The rover uses battery power when tracking those signals. To save power, enable only those signals available in the base data you are going to use. For example, the RTCM v2.3 format does not support L5 signals, so if you enable L5 in the rover but receive RTCM v2.3 from the base, the L5 signal will not be used in RTK at the rover even though the rover is tracking it*
- *GNSS surveys must contain either GPS or BeiDou observations. If you disable GPS in a GNSS survey, BeiDou is automatically enabled.*
- *GNSS receiver firmware 5.10 or later is required to perform a survey with GPS disabled.*

GPS

The *GPS* check box is available for RTCM RTK single base or multistation surveys using RTCM 3.2 (MSM) format, CMRx format rovers, and postprocessed surveys. To disable the use of GPS in those surveys, clear the *GPS* check box. If GPS signal tracking is disabled, BeiDou signal tracking is automatically enabled because surveys must contain either GPS or BeiDou data. The *xFill* check box is not available if you turn off GPS signal tracking.

If you disable GPS at the rover for RTK you can use either the CMRx or RTCM v3.2 MSM broadcast format. Disabling GPS at the base can only be done for the RTCM v3.2 MSM broadcast format. For CMRx transmission from the base, GPS must remain enabled even though GPS can be disabled at the rovers that are using that CMRx base.

The *Use L2e* check box is read-only.

For real-time surveys where the base data contains L2C observations, select the *GPS L2C* check box. Use this option only when the base receiver can track L2C.

GLONASS

For real-time surveys where the base receiver and the rover receiver can track GLONASS signals, select the *GLONASS* check box in the *Rover options* and the *Base options* screens.

You can use this setting to track GLONASS satellites at the rover even if the base receiver is not tracking GLONASS. However, the satellites will not be used in the RTK processing.

For postprocessed surveys where the base receiver and rover receivers can track the GLONASS signal, select the *GLONASS* check box if you want to use the GLONASS observations.

L5

For real-time surveys where the base receiver and the rover receiver can track L5 signals, select the *L5* check box.

Use this option only when the base receiver can track and transmit L5, and the broadcast format is set to CMRx or RTCM RTK 3.2 (MSM).

Galileo

For real-time surveys where the base receiver and the rover receiver can track Galileo signals and the broadcast format is set to CMRx or RTCM RTK 3.2 (MSM), or if you intend to use Galileo in an RTX survey, select the *Galileo* check box.

For postprocessed surveys where the base receiver and rover receivers can track Galileo test signals, select the *Galileo* check box if you want to use the Galileo test satellite observations.

Notes

- You can log Galileo satellite data only to the receiver memory.
- If you enable Galileo tracking, the satellites will be used in the solution when they are healthy. Be aware that during the in-orbit validation phase of the Galileo system, tracking performance of Galileo satellites may degrade from time to time.
- To track Galileo signals you must also track GPS signals. If you disable GPS signal tracking, the Galileo check box is not available and Galileo signal tracking is disabled.

QZSS

For real-time kinematic surveys where the base receiver and the rover receiver can track QZSS signals and the broadcast format is set to CMRx or RTCM RTK 3.2 (MSM), select the QZSS check box.

You can use this setting to track QZSS satellites at the rover even if the base receiver is not tracking QZSS satellites. However, the satellites will not be used in the RTK processing.

To fall back to QZSS SBAS positioning if your RTK radio link goes down, select *SBAS* in the *Satellite differential* field, and select the QZSS option. The QZSS option is only available if you are using CMRx as your RTK Broadcast format.

For postprocessed surveys where the base receiver and rover receivers can track the QZSS signals, select the QZSS check box if you want to use the QZSS satellite observations. This sets up the GNSS receivers to track the QZSS signals and include the signals in the logged data.

For real-time differential surveys where the rover can track the QZSS signals, select *SBAS* in the *Broadcast format* field, and select the QZSS option. This enables the rover receiver to track the QZSS satellite and, if you are within the valid QZSS differential network, to use the QZSS SBAS differential corrections in the real-time differential survey.

Notes

- You can log the QZSS satellites data only to the receiver memory.
- Both the base and rover receivers must have v4.61 firmware or later installed to track QZSS satellites in a RTK survey.

BeiDou

For real-time surveys where the base receiver and the rover receiver can track BeiDou signals, select the *BeiDou* check box.

For postprocessed surveys where the base receiver and rover receivers can track BeiDou signals, select the *BeiDou* check box if you want to use the BeiDou satellite observations. This sets up the GNSS receivers to track the BeiDou signals and include the signals in the logged data.

Notes

- *BeiDou satellites can be used in RTK surveys only if you are using a receiver that has firmware version 4.80 or later. Although logging of BeiDou satellites was available in earlier firmware versions, it is highly recommended that for postprocessed surveys you also use a receiver that has firmware version 4.80 or later.*
- *To use BeiDou in a CMR RTK survey, you must use CMRx as the broadcast format.*
- *To use BeiDou in an RTCM RTK survey, select RTCM RTK as the broadcast format for the rover, and RTCM RTK 3.2 for the base broadcast format.*
- *In a logging survey (Fast static, PPK, RTK, and logging), BeiDou can be used only if logging to the receiver.*
- *When BeiDou signal tracking is enabled in an SBAS differential survey, the BeiDou SVs are used to augment the solution if their corrections are available.*

Auto-tolerance

In an RTK survey, when you select the *Auto tolerance* check box, the software calculates horizontal and vertical precision tolerances that meet the GNSS receiver's RTK specifications for the baseline length you are measuring. If you want to enter your own precision tolerances, clear this check box. When "Store RTK initialized only" is enabled, only Initialized RTK solutions that meet the precision tolerances can be stored. Uninitialized solutions that meet the precision tolerances cannot be stored.

When "Store RTK initialized only" is not enabled, both RTK Initialized and Uninitialized solutions that meet the precision tolerances can be stored.

To change the precision level at which point storage is acceptable, clear the *Auto tolerance* check box and enter the values that you want to use.



xFill technology



Trimble xFill® technology leverages a worldwide network of Trimble reference stations to bridge communication outages via satellite-delivered correction data.

When using a GNSS receiver that supports xFill, select the *xFill* option to continue surveying during base data outages for up to 5 minutes. Note that the solution precision will degrade over this time.

When using an R10 receiver and if you have purchased access to the Trimble Centerpoint RTX correction service, select the *xFill* option to use xFill-RTX and continue surveying during base data outages indefinitely. The R10 receiver transitions to using corrections from the CenterPoint RTX correction service, with no continuing degradation of solution precision over time. The RTX solution is brought into terms with the RTK base station by the rover receiver.

xFill corrections are based on a global model aligned to WGS84. These corrections are used when the RTK radio link from the base station is lost. To achieve optimal positioning performance during xFill operation, use base station coordinates that are as close as possible to the true WGS84 coordinates for the base station point.

If xFill is not ready, the icon in the status bar is . When xFill is ready the *xFill ready* field shows Yes in the *Rover data link* screen and the status bar icon changes to . If you lose RTK corrections,

xFill takes over and the status bar icon changes to . Regaining RTK reception causes a switch back to RTK and the status bar icon returns to .

If you are using the R10 receiver, once RTX has converged the *xFill-RTX ready* field shows Yes in the *Rover data link* screen. When the receiver transitions to using corrections from the CenterPoint

RTX correction service, the status bar icon changes to .

Notes

- *To use this option, your GNSS receiver must support xFill.*
- *xFill is not available if OmniSTAR has been selected or if GPS signal tracking has been disabled.*
- *Using xFill with receiver firmware earlier than version 4.80 requires the WGS84 coordinates of your RTK base to be accurate to within 1 meter of the correct WGS84 coordinate of that base point. When establishing a field base station using the Here key in Trimble Access, the required accuracy of the base coordinates may be achieved when the position is augmented with SBAS. If using xFill with network RTK such as VRS™, subscribers should check with their network administrator that the network is providing base coordinates and correction data in a global reference frame aligned with ITRF2008 or WGS84.*
- *When measuring a point in xFill, the precisions cannot converge until xFill begins to use the CenterPoint RTX correction service. Until then the best position is the single measurement at the beginning of the occupation. For this reason, any point measured when using xFill technology prior to the transition to using RTX will become acceptable after 1 second. The Occupation time and Number of measurements settings in Options are overridden by the 1 second rule during xFill mode.*
- *If you are using an RTX (SV) survey with hourly blocks purchased for the RTX correction service, an "End RTX tracking to stop subscription timer?" message appears when you end the survey. Select Yes to disable the RTX SV tracking in the receiver. When you start a new survey using the RTX service, you will need to wait for the solution to re-converge. If you wish to start another survey in a relatively short period of time after ending the current survey, and you don't want to wait for the RTX solution to re-converge, select No. Selecting No means your RTX subscription will continue to use time even though you are not in a survey, but the next survey will start with a converged solution if RTX and GNSS tracking is maintained between surveys. For RTX (Internet) surveys using hourly blocks purchased for the RTX correction service, the software stops using the RTX correction service as soon as you end the survey because the Internet connection is automatically disconnected.*
- *Trimble Access continues storing RTK vectors and all points are measured relative to the same RTK coordinate system.*
- *xFill is only available for areas covered by the broadcast satellite. For more information see: www.trimble.com*
- *When using xFill, the SBAS status screen shows the current Correction satellite name. To select a different satellite, tap DataLnk to go to the Rover data link screen, tap RTX SV and then select the required satellite from the list. Alternatively, select Custom and then enter the frequency and bit rate to use. You can change the correction satellite at any time; changing the correction satellite does not require restarting the survey. Changes you make to the settings are used the next time you start a survey.*

Tilt

Select the *Tilt* option when using a GNSS receiver with an in-built tilt sensor so that the *Tilt warnings* and *Tilt auto-measure* options are available when you define the style for a *Topo point*, *Rapid point*, or *Compensated point*. The Tilt option setting also makes the Tilt warnings option available when you define the style for an *Observed control point* or *Continuous points*.

Note - The *Compensated point measurement method* is not available in the *Measure* screen if the *Tilt option* is turned off.

Data link options

The General Survey software provides a **Real-Time Kinematic** survey style. Real-time kinematic surveys use a [data link](#) to send observations or corrections from the base station to the rover. The rover then calculates its position in real time.

The following types of data link can be configured:

Select	If you are using	For more information, see
Radio	an internal or external radio	Configuring a radio data link
Internet connection	an external modem or a Trimble internal modem for a mobile Internet connection	Configuring an Internet data link
Dial-in	an external modem or Trimble internal modem for a circuit-switched dial-in connection	Configuring a dial-in data link

Measurement method options

As part of [configuring the survey style](#) for a GNSS survey, you can configure the parameters for the measurement methods you will use during the survey.

Auto point step size

Sets the increment size for automatic point numbering. The default is 1, but you can use larger step sizes and negative steps.

Quality control

You can store quality control information with each point measurement except compensated points. Options may include *QC1*, *QC1 & QC2*, and *QC1 & QC3*, depending on the type of survey.

Quality control 1: DOP and Time

Number of satellites (minimum for the occupation and number at time of storage), Flag for Relative DOPs (or not, used for legacy firmware that produced RDOP when static), DOP (maximum for duration of occupation), DOP at time of point storage, RMS (legacy systems only, in millicycles, this is from instant before going static to show roving environment, not a converged static reading),

Number of GPS positions used in the occupation (this is the number of epochs within precision tolerance observed), Horizontal standard deviation and Vertical standard deviation field are unused (set to null), Start GPS week (the GPS week when you hit Measure), Start GPS time in seconds (the GPS second of week when you hit Measure), End GPS Week (the GPS week the point was stored), End GPS time in seconds (the GPS second of week when the point was stored, Monitor Status (not used, will be null or not visible), RTCMAge (age of corrections used in RTK solution), Warnings (which warning messages were issued during the occupation or in effect when the point was stored).

Quality control 2: Variance/Covariance matrix of the RTK solution

Error scale (added trace of covariance matrix divided by PDOP, used to convert DOPs into precisions in legacy systems), VCV xx, VCV xy, VCV xz, VCV yy, VCV yz, VCV zz (these are all a-posteriori variances from the stored epoch of the RTK solution), Unit Variance (standard error of unit weight, always set to 1.0 for HD-GNSS, not available in some legacy systems). All values at 1-sigma level.

Quality control 3: Error ellipse of RTK solution

This is in local tangent plane and is calculated directly from VCVs using standard textbook formulae. Sigma north (standard deviation in the north component), Sigma east (standard deviation in the east component, Sigma up (standard deviation in the Up or height component), Covariance east-north (measure of the correlation between the east error and the north error), Semi major axis length of error ellipse in meters, Semi minor axis length of error ellipse in meters, Orientation from north of error ellipse, Unit variance of solution. All values at 1-sigma level.

Auto store point

Select the *Auto store point* check box to automatically store the point when the preset occupation time and precisions have been met.

This check box does not appear in the Rapid point measurement options because rapid points are always stored automatically.

Occupation time and number of measurements

The *Occupation time* and *Number of measurements* together define the time that the receiver is static while measuring a point. The criteria for both must be met before the point can be stored. The *Occupation time* defines the length of clock time for the occupation. The *Number of measurements* defines the number of valid sequential GNSS measurement epochs that meet the currently configured precision tolerance that must occur during the period of the occupation time. When the *Occupation time* and *Number of measurements* criteria have been met, *Store* is available. Alternatively, if *Auto store point* is enabled, the point is stored automatically.

Note - For compensated points and observed control points measured during an RTK survey, the horizontal and vertical precisions must also be satisfied before the point can be stored.

If a point is stored manually when the precision tolerances are not met, the number of measurements that meet the precision criteria will be zero, and this is what will appear in the point record in *Review job*.

The requirement for sequential epochs that meet the precision criteria means the occupation counters will be reset if the precision goes outside the tolerances at any time during the occupation.

In an RTK survey, the RTK engine in the GNSS receiver converges on a solution during the occupation and it is this converged solution that is saved in the General Survey job file when the point is stored.

In a FastStatic survey, the default occupation times are satisfactory for most users. If you change an occupation time, choose a setting according to the number of satellites being tracked by that receiver.

Note - *Changing the occupation times directly affects the outcome of a FastStatic survey. Any changes should increase this time rather than decrease it. If you do not record enough data, the points may not be successfully postprocessed.*

Auto tolerance

In an RTK survey, when you select the *Auto tolerance* check box, the software calculates horizontal and vertical precision tolerances that meet the GNSS receiver's RTK specifications for the baseline length you are measuring. If you want to enter your own precision tolerances, clear this check box. When "Store RTK initialized only" is enabled, only Initialized RTK solutions that meet the precision tolerances can be stored. Uninitialized solutions that meet the precision tolerances cannot be stored.

When "Store RTK initialized only" is not enabled, both RTK Initialized and Uninitialized solutions that meet the precision tolerances can be stored.

To change the precision level at which point storage is acceptable, clear the *Auto tolerance* check box and enter the values that you want to use.

Tilt settings

When using a GNSS receiver with an in-built tilt sensor, you can select:

- *Tilt auto-measure* to auto-measure points when the pole is within a specified *Tilt tolerance*
- *Tilt warnings* to prompt a warning when the pole is outside a specified *Tilt tolerance*

Tip - To enable these options, select *Survey Styles / Rover options* and then select *Tilt*.

Auto abandon

Select *Auto abandon* to abandon and restart the measurement process. When selected, points measured using a GNSS receiver with an in-built tilt sensor that experience excess tilt, or, for all receivers, excess movement, during the measurement process will be abandoned and the measurement process restarted.

HDR

This check box appears only if you are using a V10 imaging rover. For more information, see [HDR imaging](#).

Store low latency positions

This check box only appears in the Continuous topo measurement method options when you do not have Trimble RTX or xFill enabled.

When you select the *Store low latency positions* check box, the measurements are made by the receiver in low latency mode. Low latency is more suitable when using continuous topo with distance based tolerances.

When *Store low latency positions* is not enabled, measurements from the receiver are synchronized on the epoch resulting in slightly more accurate positions, and is more suitable when using continuous topo with time-based tolerances.

Tip - If using Continuous topo as a static test to check the quality of measured positions make sure *Store low latency positions* is not enabled.

PP initialization times

If you have configured a PP Kinematic survey type, the PP initialization times screen appears in the survey style settings list.

Select the *PP initialization times* survey style option to define initialization times. Generally the default settings are appropriate.

In a postprocessed survey, collect enough data during initialization so that the postprocessor can successfully process it. Recommended times are as follows.

Initialization method	4 SVs	5 SVs	6+ SVs
L1/L2 on-the-fly initialization	N/A	15 min	8 min
L1/L2 new point initialization	20 min	15 min	8 min
Known Point initialization	at least four epochs		

Notes

- *The time to initialize counters are paused when the PDOP of the satellites being tracked exceeds the PDOP mask set in the survey style being used. The counters resume when the PDOP falls below the mask.*
- *You cannot initialize if the PDOP is greater than 20.*

WARNING - Reducing any of these times can affect the outcome of a postprocessed survey.

Minimum L1/L2 satellites required for on-the-fly initialization

The number of satellites required depends on whether you are using GPS satellites only, BeiDou satellites only, or a combination of GPS, BeiDou, GLONASS, Galileo and QZSS satellites. The following table summarizes the minimum requirements for on-the-fly initialization.

Satellite systems	Required satellites
GPS only	5 GPS
GPS + QZSS	4 GPS + 1 QZSS
GPS + GLONASS	4 GPS + 2 GLONASS
GPS + BeiDou	4 GPS + 2 BeiDou
GPS + Galileo	4 GPS + 2 Galileo

Satellite systems	Required satellites
BeiDou only	5 BeiDou
BeiDou + GPS	4 BeiDou + 2 GPS
BeiDou + GLONASS	4 BeiDou + 2 GLONASS
GLONASS only	N/A
Galileo only	N/A

Minimum L1/L2 satellites required to maintain initialization, produce positions, and for new point initialization

After initialization, a position can be determined and the initialization can be maintained with one satellite less than the number required to initialize. If the number of satellites drops below this number, the survey must be reinitialized.

The number of satellites required for new point initialization depends on whether you are using GPS satellites only, BeiDou satellites only, or a combination of GPS, BeiDou, GLONASS, Galileo and QZSS satellites.

The following table summarizes the requirements.

Satellite systems	Required satellites
GPS only	4 GPS
GPS + QZSS	3 GPS + 1 QZSS
GPS + GLONASS	3 GPS + 2 GLONASS
GPS + BeiDou	3 GPS + 2 BeiDou
GPS + Galileo	3 GPS + 2 Galileo
BeiDou only	4 BeiDou
BeiDou + GPS	3 BeiDou + 2 GPS
BeiDou + GLONASS	3 BeiDou + 2 GLONASS
GLONASS only	N/A
Galileo only	N/A

After initialization, the survey mode changes from *Not initialized* to *Initialized*. The mode remains *Initialized* if the receiver continuously tracks the minimum number of satellites. If the mode changes to *Not initialized*, you must reinitialize the survey.

Note - The QZSS system operates in the same time-base as GPS and therefore is included in the counters as another GPS satellite.

Setting up the equipment for a rover receiver

This section describes how to assemble the hardware at the rover receiver for a real-time and postprocessed kinematic (PP kinematic) survey. It describes the steps for a Trimble integrated GNSS receiver.

To set up a rover Trimble integrated GNSS receiver:

1. Mount the receiver onto a range pole. Power for the receiver is supplied by the internal battery in the receiver.
2. Attach the controller to the holder. See [Trimble CU controller](#).
3. Connect the controller holder to the range pole.
4. Turn on the receiver.
5. Turn on the controller.

Note - In a postprocessed survey you may find it useful to use a bi-pod to hold the range pole while taking measurements.

To configure the rover receiver in the Trimble Access software, see [Rover and base options](#).

Measuring antenna heights

The following describes how to measure the height of an antenna mounted on a range pole when the *Measured to* field is set to *Bottom of antenna* or *Bottom of antenna mount*. With a fixed height range pole, the height is a constant value.

Zephyr antenna

Refer to the following diagram where (1) is the Zephyr antenna, (2) is the corrected height to APC and (3) is the uncorrected height.

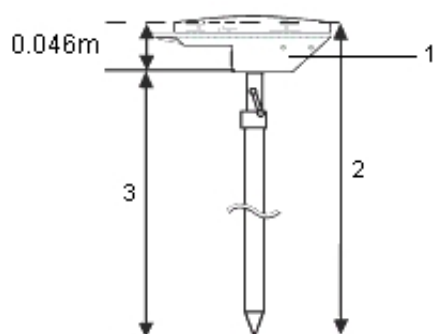

If this antenna is mounted on a tripod, measure the height to the top of the notch on the side of the antenna.

Zephyr geodetic antenna

If this antenna is mounted on a tripod, measure the height to the bottom of the notch on the side of the antenna.

Trimble integrated GNSS receiver

Refer to the following diagram where (1) is the Trimble GNSS receiver, (2) is the corrected height to APC and (3) is the uncorrected height of 1.80m.

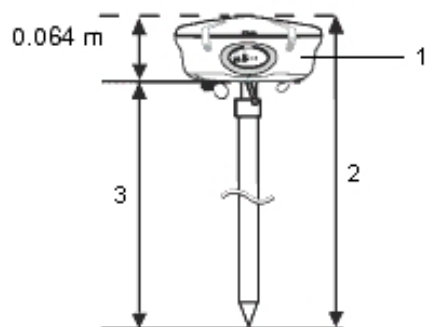

If this receiver is mounted on a tripod, measure the height to the bottom of the groove between the gray base and the white top of the antenna, and select *Center of bumper* in the *Measured to* field.

Tip - If you are using a fixed height tripod, you can measure the height to the bottom of the antenna housing and select *Bottom of antenna mount* in the *Measured to* field.

Micro-centered L1/L2 antenna

Refer to the following diagram where (1) is the Micro-centered antenna, (2) is the corrected height to APC and (3) is the uncorrected height.

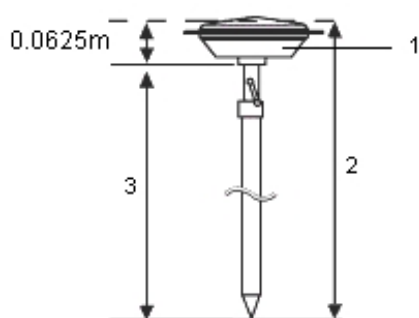

If this antenna is mounted on a tripod, measure the height to the bottom of the plastic housing. Enter this value in the *Antenna height* field and set the *Measured to* field to *Bottom of antenna*.

Tornado antenna

Refer to the following diagram where (1) is the Tornado antenna, (2) is the corrected height to APC and (3) is the uncorrected height.

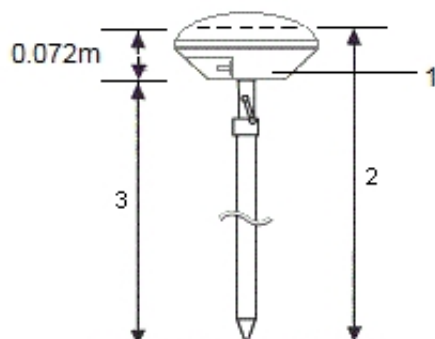

If this antenna is mounted on a tripod, measure the height to the join between the grey and white plastics on the antenna.

Trimble Geo7X and Trimble GeoXR

Refer to the following diagram where (1) is the bottom of the receiver, (2) is the electrical phase center and (3) is the APC.

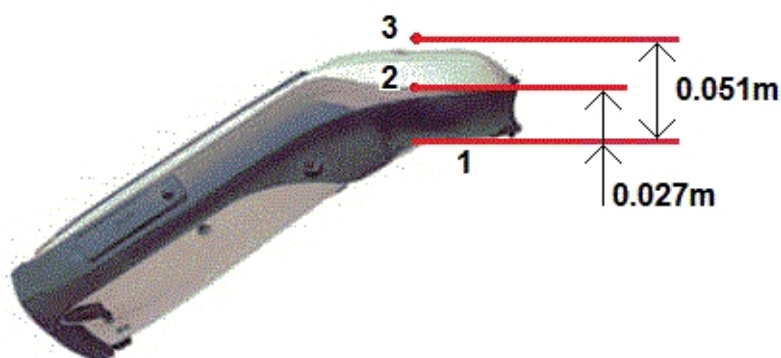

When using the Geo7X/GeoXR mounted on a monopole, select *Bottom of monopole bracket* as the *Measure to* method.

Note - The Geo7X can be used with the version one monopole bracket only if it does not have the laser rangefinder module attached. The Geo7X can be used with the version 2 monopole bracket with or without the laser rangefinder module attached.

Note - If the Geo7X/GeoXR is mounted on the version 1 monopole bracket, the distance from the bottom of the monopole bracket to the APC (3) is 0.095 m. On the version 2 monopole bracket, the distance from the bottom of the monopole bracket to the APC (3) is 0.128 m.

Trimble R10 receiver

Refer to the following diagram where (1) is the Trimble R10 receiver, (2) is the bottom of the antenna mount, (3) is the bottom of the quick release, (4) is the corrected height to the APC from the bottom of the pole.



The following describes how to measure the height of an Trimble R10 receiver using the lever on the R10 extension, when the R10 is mounted on a tripod.

Refer to the following diagram where (1) is the Trimble R10 receiver, (2) is the lever of the R10 extension, (3) is the corrected height to the APC from the ground mark and (4) is the uncorrected height.

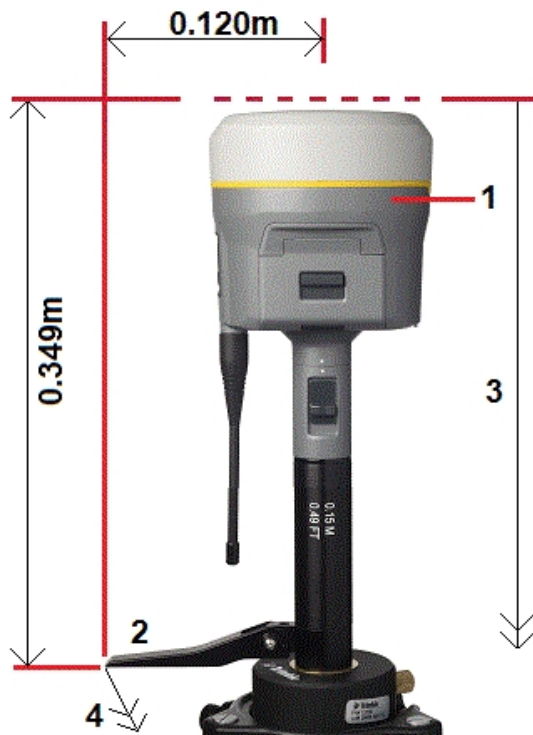

Ground plane

If you are using a ground plane, see the next section.

Measuring the height of an antenna when using a ground plane

If the Micro-centered antenna (or a Compact L1/L2 antenna) has a ground plane measure to the underside of the notch in the ground plane.

Refer to the following diagram where (1) is the Micro-centered L1/L2 antenna, (2) is the ground plane, (3) is the underside of the notch and (4) is the top of the notch.

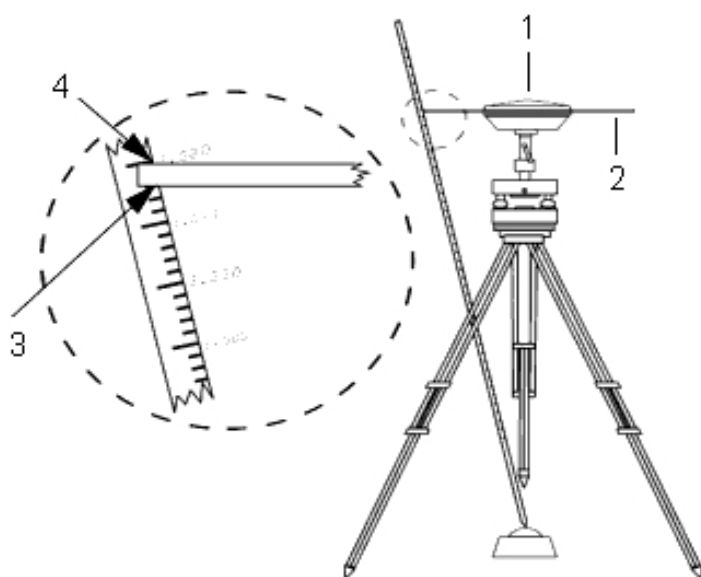

Tip - Measure the height to three different underside notches around the perimeter of the ground plane. Then record the average as the uncorrected antenna height.

Antenna.ini file

The General Survey software includes an integrated Antenna.ini file that contains a list of antennas that you can choose from when creating a survey style. You cannot edit this list in the General Survey software. However, if you want to shorten the list or add a new antenna type, you can edit and transfer a new Antenna.ini file.

To edit the antenna.ini file, use a text editor such as Microsoft Notepad. Edit the *General Survey* group, and transfer the new Antenna.ini file to the General Survey software, using Trimble's Data Transfer utility.

Note - When you transfer an Antenna.ini file, it overwrites any existing file of that name. The information in this file is also used in preference to the antenna information built into the General Survey software.

Base receiver setup

Note - Use the information in this section if you will set up your own receiver as a base receiver.

This topic has the following sections:

[Base station coordinates](#)

[Setting up the equipment for a real-time survey](#)

[Setting up the equipment for a postprocessed survey](#)

Setting up the equipment for a real-time and postprocessed survey

Starting a base survey

Ending a base survey

To configure the base receiver in the Trimble Access software, see [Rover and base options](#) and [Configuring a radio data link](#).

Base station coordinates

When you set up a base, it is important to know the WGS-84 coordinates of the point as accurately as possible.

Note - Every 10 m of error in a base station coordinate can introduce a scale error on every measured baseline of up to 1 ppm.

The following recognized methods, listed in descending order of accuracy, are used to determine base station WGS-84 coordinates:

- Published or precisely-determined coordinates.
- Coordinates computed from published or precisely-determined grid coordinates.
- Coordinates derived using a reliable differential (RTCM) broadcast based on published or precisely-determined coordinates.
- An SBAS position generated by the receiver. Use this method if no control exists for the location and you have a receiver that tracks SBAS satellites.
- An autonomous position generated by the receiver. Use this method for real-time surveys in a location where no control exists. Trimble strongly recommends that you calibrate any jobs started by this method on a minimum of four local control points.

Tip - In the U.S.A., you can regard NAD83 geodetic coordinates as equivalent to WGS-84 coordinates.

Note - If the keyed in WGS-84 coordinates differ from the current autonomous position generated by the receiver by more than 300 m, a warning message appears.

For more information about entering base station coordinates, see [Starting a base survey](#).

Survey integrity

To preserve the integrity of a GNSS survey, consider the following:

- When you start subsequent base receivers for a particular job, make sure that each new base coordinate is in the same terms as the initial base coordinate.

Note - Within a job, only use an autonomous position to start the **first** base receiver. An autonomous position is equivalent to an assumed coordinate in conventional surveying.

- Coordinates published by a reliable source and coordinates determined by control surveys should be in the same system.
- If subsequent base coordinates are not in the same terms, regard observations from each base as a separate job. Each needs a separate calibration.
- Because measured real-time kinematic points are stored as vectors from the base station, not as absolute positions, the origin of the survey must be an absolute WGS-84 position from

which the vectors radiate. If other base stations are subsequently set up on points measured from the original base station, all vectors are resolved back to the original base station.

- It is possible to start the base on any kind of coordinates, for example, grid or local ellipsoid coordinates. However, in a real-time survey, the General Survey software must store a WGS-84 position for the base when a rover survey is started. It is this position that is held fixed as the origin of the network.

When you start a rover survey, the General Survey software compares the WGS-84 position broadcast by the base receiver with points already in the database. If a broadcast point has the same name as a point in the database, but different coordinates, the General Survey software uses the coordinates that are in the database. These coordinates were keyed in or transferred by you, so it assumes that you want to use them.

If a point in the database has the same name as the one being broadcast by the base, but the coordinates are NEE or local LLH rather than WGS-84 coordinates, the General Survey software converts this point to WGS-84 coordinates using the current datum transformation and projection. It then uses these as the base coordinates. If no datum transformation and projection are defined, the broadcast WGS-84 point is automatically stored and used as the base.

The following diagram shows a survey using two base stations.

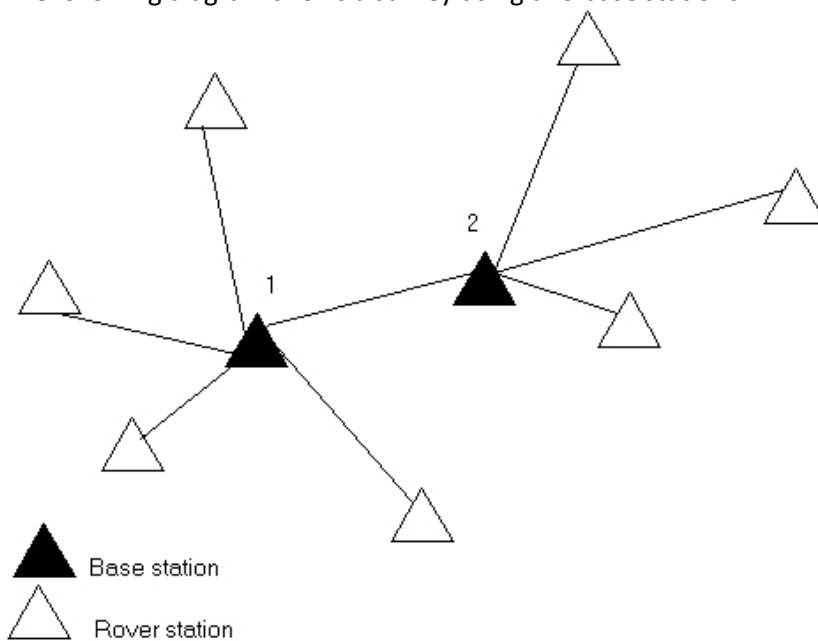

In this survey, Base station 2 was first surveyed as a roving point from Base station 1.

Note - Base stations 1 and 2 **must** be linked together by a measured baseline, and Base station 2 **must** be started with the same name that it had when it was surveyed as a roving point from Base station 1.

Setting up the equipment for a real-time survey

This section describes how to assemble the hardware components at the base receiver for a Real-time kinematic (RTK) or Real-time differential (RT differential) survey.

Using a Trimble modular GNSS receiver

To set up a base receiver for a real-time survey using a Trimble modular GNSS receiver:

1. Set the Zephyr antenna over the ground mark using a tripod, a tribrach, and a tribrach adaptor.
2. Use the tripod clip to hang the receiver on the tripod.
3. Connect the Zephyr antenna to the GNSS receiver port labeled "GPS". Use the GNSS antenna cable.

Note - *Instead of hanging the receiver on the tripod, you can place the receiver in its base case. Run the antenna cable out of the portal in the side of the base case to the antenna so that the case can stay closed while the receiver is running.*

4. Assemble and erect the radio antenna.
5. Connect the radio antenna to the radio using the cable attached to the antenna.
6. Connect the radio to the GNSS receiver port 3. If you are using:
 - A Trimble radio, use the supplied cable.
 - A radio provided by a third party, use the appropriate cable.

Note - *For some third-party radios, a separate power supply is needed for the radio.*

WARNING - Do not force plugs into the receiver ports. Align the red dot on the plug with the red line on the socket and then insert the plug carefully.

7. If external power is required, connect the power supply with a 0-shell Lemo connection to port 2 or port 3 on the receiver.
8. Connect the controller to the GNSS receiver port 1 using the 0-shell Lemo-to-Hirose cable.
9. Turn on the controller, then follow the instructions in [Starting a base survey](#).

Setting up the equipment for a postprocessed survey

This section shows how to assemble the hardware components at the base receiver for a postprocessed kinematic, or a FastStatic survey.

Using a Trimble modular GNSS receiver

To set up the base receiver for a postprocessed survey:

1. Set the Zephyr antenna over the ground mark using a tripod, a tribrach, and a tribrach adaptor.
2. Use the tripod clip to hang the receiver on the tripod.
3. Connect the Zephyr antenna to the GNSS receiver port labeled "GPS". Use the GNSS antenna cable.

Note - Instead of hanging the receiver on the tripod, you can place the receiver in its base case. Run the antenna cable out of the portal in the side of the base case to the antenna so that the case can stay closed while the receiver is running.

WARNING - Do not force plugs into the receiver ports. Align the red dot on the plug with the red line on the socket and then insert the plug carefully.

4. If external power is required, connect the power supply with a 0-shell Lemo connection to Port 2 or Port 3 on the receiver.
5. Connect the controller to the GNSS receiver port 1 using the 0-shell Lemo to 0-shell Lemo cable.
6. Turn on the controller, then follow the instructions in [Starting a base survey](#).

Setting up the equipment for a real-time and postprocessed survey

To conduct a survey that uses both real-time and postprocessed techniques, follow the assembly instructions for real-time surveys. If the receiver has no memory (or has a limited memory), use a controller to store raw data at the base receiver.

Starting a base survey

To conduct a survey using a predefined survey style, make sure that the required job is open. The title of the main menu should be the current job name.

From the main menu, choose *Measure* and select a survey style from the list.

A *Measure* menu is generated. It displays items specific to the chosen survey style and includes the *Start base receiver* and measure options.

WARNING - In a real-time survey, make sure that the radio antenna is connected to the radio before starting the base survey. If it is not, the radio will be damaged.

To start a base survey:

1. From the *Measure* menu, tap *Start base receiver*.
 - If the controller is connected to a receiver that was logging data, the data logging stops.
 - If the base survey requires an internet connection and one doesn't already exist, the connection is established.
 - The first time that you use this survey style, the Style wizard prompts you to specify the equipment you are using.

The style wizard customizes the chosen survey style, setting any parameters specific to the hardware.

Notes

- To correct a mistake when customizing a survey style, first complete the process and then edit the style.
- When using Trimble GNSS receivers that do not have the UHF Transmit option, use an external radio at the base even if you use the internal radio at the rover.
- You can use a Custom radio if the radio you have is not listed.

The *Start base* screen appears.

Note - When you start a survey, the General Survey software automatically negotiates the highest possible baud rate for communicating with the connected receiver.

2. Enter the base station name and coordinates. Use one of the following methods:
 - If WGS84 coordinates are known:

Access the *Point name* field and enter the point name. Tap *Key in*.

In the *Key in point* screen, set the *Method* field to *Keyed in coordinates*. Check that the coordinate fields are *Latitude*, *Longitude*, and *Height (WGS84)*. If they are not, tap *Options* and change the *Coordinate view* setting to *WGS84*. Key in the known WGS84 coordinates for the base station, and tap *Store*.
 - If grid coordinates are known, and projection and datum transformation parameters are defined:

Access the *Point name* field and enter the point name. Tap *Key in*.

In the *Key in point* screen, set the *Method* field to *Keyed in coordinates*. Check that the coordinate fields are *Northing*, *Easting*, *Elevation*. If they are not, tap *Options* and change the *Coordinate view* setting to *Grid*. Key in the known grid coordinates for the base station, then tap *Store*.
 - If local geodetic coordinates are known and a datum transformation is defined:

Access the *Point name* field and enter the point name. Tap *Key in*.

In the *Key in point* screen, check that the coordinate fields are *Latitude*, *Longitude*, and *Height (Local)*. If not, tap *Options* and change the *Coordinate view* setting to *Local*. Key in the known local coordinates for the base station, then tap *Store*.
 - If the coordinates of the point are unknown:

In a real-time survey, to use either the current SBAS position (if tracked), or the current autonomous position derived by the GNSS receiver, access the *Point name* field and enter the point name. Tap *Key in* to access the *Key in point* screen. Tap *Here* and the current position is displayed. Tap *Store* to accept and store this position.

Note - If you want an SBAS position, ensure the receiver is tracking an SBAS satellite by checking the SBAS icon is displayed on the status line when you tap *Here*. The receiver can take 120 seconds to lock on to SBAS. Alternatively, check the *Observation class* field before starting the base.

WARNING - Within a job, only use an autonomous position (the *Here* softkey) to start the first base receiver.

Notes

- If you carry out a real-time survey using RTCM 2.x corrections and use a base point name that is more than eight characters long, the name will be shortened to eight characters when it is broadcast.
 - If you carry out a real-time survey using RTCM 3.0 corrections, you must use a base point name (in upper case) that is within the range RTCM0000 to RTCM4095.
3. The *Observation class* field shows the observation class of the base point. For more information, see [Storing points](#).
 4. Enter values in the *Code* (optional) and *Antenna height* fields.
 5. Set the *Measured to* field as appropriate.

- In the *Station index* field, enter a value.

This value is broadcast in the correction message, and must be in the range 0-31.

Tip - Tap *Scan* to view a list of other base stations operating on the frequency you are using. The list shows the station index numbers of the other bases and the reliability of each. Choose a different station index number to those displayed.

- If the receiver you are using supports transmission delays, the *Transmission delay* field appears. Choose a value depending on how many base stations you intend to use. For more information about transmission delays, see [Operating several base stations on one radio frequency](#).
- Tap *Start*.

The base receiver starts to record data and transmit corrections in the format selected in the Survey Style.

- Do one of the following:

- If you are carrying out a real-time survey, the following message appears:

Base started

Disconnect controller from receiver

Disconnect the controller from the base receiver but **do not** turn off the receiver. You can now set up the rover receiver.

Note - For a real-time survey, check that the radio is working before leaving the equipment. The data light should be flashing.

- If you are logging data in the controller, and/or you are uploading corrections to a remote server, the *Base* screen appears. It shows which point is being surveyed and the time that has elapsed since data logging started. Leave the Trimble controller connected to the base receiver and set up the rover using another Trimble controller.
- If your base is operating as an internet server, the *Base* screen appears and in addition to the above, it shows the IP address that has been assigned to the base, as well as the number of rovers that are currently connected to the base.

Ending a base survey

When all rover surveys using your base are complete, return to the base, connect the controller to the base receiver and then select *Measure / End GNSS base survey*. If the controller was logging base data, tap *End* on the *Base* screen.

Operating several base stations on one radio frequency

In an RTK survey you can reduce the effects of radio interference from other base stations on the same frequency by operating your base station with a different transmission delay. This allows you to operate several base stations on one frequency.

The general procedure is as follows:

1. Check that you have the correct hardware and firmware.
2. Set up the equipment and start a survey at each base station, specifying a transmission delay and a station index number.
3. Start a rover survey and specify which base to use.

Hardware and firmware requirements

To operate several base stations on one frequency, you must use receivers that support the CMR+ or CMRx correction format.

All other base and rover receivers must be Trimble R / 5000 series GNSS receivers.

Note - Do not use transmission delays if you intend to use radio repeaters.

Starting the base with a transmission delay

When you use multiple base stations, you set the transmission delay for each base when you start the base survey. Each base must broadcast with a different transmission delay and station index number. The delays allow the rover to receive corrections from all of the base stations at once. The station index numbers let you select which base station to use at the rover.

Note - You can set the base radio transmission delay only when using Trimble R / 5000 series GNSS receivers. When you carry out surveys using different base stations in one job, make sure that the coordinates of the base stations are in the same coordinate system and are in terms of each other.

Before you start the base receiver, do the following:

1. Select the CMR+ or CMRx correction format. Select this in the survey style for both the base and the rover.
2. Set the over air baud rate in the radio to at least 4800 baud.

Note - If you use a 4800 over air baud rate you can only use two base stations on one frequency. Increase the over air baud rate if you want to increase the number of base stations on one frequency.

When you start the base survey, do the following:

1. In the *Station index* field, enter a value within the range 0-31. This number is broadcast in the correction message.

Tip - You can configure the default station index number in the survey style. For more information, refer to [Station index](#).

2. If the receiver you are using supports transmission delays, the *Transmission delay* field appears. Choose a value, depending on how many base stations you want to use. See the following table.

No. of base stations	Use these delays (in ms) ...			
	Base 1	Base 2	Base 3	Base 4
One	0	-	-	-
Two	0	500	-	-
Three	0	350	700	-
Four	0	250	500	750

For more information about starting the base survey, see [Base receiver setup](#).

For information about starting the rover and selecting which station index to use, see [Start the survey](#).

Swapping bases during a real-time rover survey

If you are using multiple bases on the same frequency, you can swap bases during the rover survey.

To swap bases, from the *Measure* menu, select *Swap base receiver*.

The *Select base station* screen appears. It shows all the base stations operating on the frequency you are using. The list shows the station index numbers of each base and the reliability of each. Tap the base you want to use.

Note - When you change to a different base, your OTF receiver automatically starts the initialization.

Wide-area RTK surveys

Wide-area RTK (WA RTK) systems, also called Network RTK systems, consist of a distributed network of reference stations communicating with a control center to calculate GNSS error corrections over a wide area. Real-time correction data is transmitted by radio or cellular modem to the rover receiver within the network area.

The system improves reliability and operating range by significantly reducing systematic errors in the reference station data. This lets you increase the distance at which the rover receiver can be located from the physical reference stations, while improving on-the-fly (OTF) initialization times.

The General Survey software supports broadcast formats from the following WA RTK solutions:

- FKP (RTCM)
- VRS
- RTCM3Net

To use a WA RTK system, first check that you have the necessary hardware and firmware.

Hardware requirements

All rover receivers must have firmware that support WA RTK. For details of availability, check the Trimble website or contact your local reseller.

Real-time correction data is provided by radio or cellular modem. For details about the delivery option for your system, contact your local reseller.

Configuring the survey style

Before you start a survey using a WA RTK system, configure the RTK survey style.

To select a WA RTK broadcast format:

1. From the Trimble Access menu, tap *Settings / Survey styles / <Style name> / Rover options*.
2. In the *Broadcast format* field, select one of the following options from the list:
 - *FKP (RTCM)*
 - *VRS (RTCM)*
 - *VRS (CMR)*
 - *RTCM3Net*

To store VRS vectors to the nearest Physical Base Station (PBS) in the VRS network, the VRS system must be configured to output the PBS information. If the VRS system does not output PBS data, VRS data must be stored as positions.

To select a radio solution:

1. In the survey style, select *Rover data link*.
2. In the *Type* field, select your radio from the list.

Note - If you are using a radio in a VRS system, you must select a two-way radio. You cannot use Trimble internal 450 MHz or 900 MHz radios.

RTK on demand

If you are using an Internet connection to send RTK data from the base to the rover, then you can use the General Survey RTK on demand functionality to control the amount of data broadcast from the base receiver. You can request the base station to send data only when you require it. This will reduce the amount of data received by your cellular phone and may reduce costs from your cellular network service provider.

The RTK on demand function requires an Internet connection at both the GNSS base station and the rover. The General Survey software must be at both the GNSS base station and the rover, or you must be connected to a Trimble VRS 3 Net, Trimble GPSNet or GPSBase infrastructure system. Once the RTK survey is running over an Internet connection, you can access the *RTK on demand* controls by tapping the  icon in the status bar.

When the survey is started, General Survey will default to Play  mode. When in Play mode, RTK data will be streamed continuously.

If you tap the  softkey, your survey will go into Pause mode and data will only be streamed when required. General Survey will request data from the base station when initialization is lost, or when you choose to measure a point, or when you start continuous topo, or when you use the stakeout functionality. As soon as the receiver has regained initialization, or the survey task is complete, then General Survey will request the base station to stop streaming data.

Note - When in Pause mode, you cannot measure rapid points or fast fix points.

If you tap the  softkey then your survey will go into Stop mode and no RTK data will be streamed. This can be used in situations where you do not wish to end your survey, but do not require the receiver to stay initialized until you are ready to start surveying again.

RTX correction service

If you have a Trimble receiver that supports Trimble RTX™ technology and has a Trimble RTX subscription you can use the Trimble Centerpoint® RTX correction service.

The Trimble Centerpoint RTX correction service is a high-accuracy, precise point positioning (PPP) system that provides real-time centimeter positioning without the need for an RTK base station or VRS network.



Survey using satellite-delivered or Internet-delivered Trimble RTX corrections in open areas where terrestrial-based corrections are not available. When surveying over a great distance in a remote area, such as a pipeline or utility right of way, RTX eliminates the need to continuously move the base station or, when using satellite-delivered corrections, to maintain connection to cell coverage.

In typical conditions, the RTX convergence time is 30 minutes or less when static. The convergence time varies based on GNSS constellation health, level of multipath, and proximity to obstructions, such as large trees and buildings.

RTX QuickStart allows rapid re-convergence on a previously surveyed point or a known survey control point. RTX QuickStart typically converges in less than 5 minutes.

Performing an RTX survey

1. Create an RTK survey style with the broadcast format set to *RTX (SV)* or *RTX (Internet)*.
2. If you select *RTX (Internet)*, in the *Rover options* screen, in the *Rover data link* screen select the GNSS contact you have set up for the RTX Internet service. This GNSS contact must have the *Use RTX (Internet)* check box selected and the appropriate *Mountpoint name* selected. For more information, see [Creating a GNSS contact for an Internet data link](#).
3. Start a survey using this survey style.
4. Select the appropriate tectonic plate. The list is filtered to show only those plates closest to your current position.

When RTX (SV) signals are being received, the radio icon changes to an RTX icon , and RTX appears on the status line. Tap  to see the RTX status.

When data from the CenterPoint RTX correction service is being received via the Internet, the network connection icon  appears.

Wait for convergence. Convergence can take up to 30 minutes in typical conditions.

5. Once convergence has been gained you can begin surveying.

RTX QuickStart on a known point

1. Do one of the following:
 - During an RTX (SV) survey, tap  to view the *RTX status* screen and then tap *QStart*.
 - During an RTX (Internet) survey, from the *Instrument* menu tap *RTX status* and then tap *QStart*.
2. Set up the receiver on the known point and then enter the details for the point, or select it from the list.

The known point used must be either an RTX measurement, or a point that when put through the current coordinate system, site calibration, and RTX-RTK Offset, resolves to the same terms as an RTX measurement. For more information, see [Combining RTK and RTX in the same job](#).
3. Tap *Start*. The *Start* button appears only when RTX positions are being calculated. Wait for convergence. Convergence time is typically less than 5 minutes.
4. When the message "Convergence has been gained" appears, you can continue surveying.

Notes

- *Convergence times given are a guide only. Convergence may take longer in adverse environments.*
- *Although the RTX rover solution may have converged, it may not yet meet the precision tolerances for point measurement. You may need to remain at a point longer to meet the precision tolerances specified, as the RTX rover solution should converge more when the rover is in static mode. Precisions for surveys using the Trimble Centerpoint RTX service are very sensitive to environmental conditions such as multipath, ionosphere scintillation, and particularly tropospheric conditions and tree canopy.*
- *To change the precision level at which convergence is acceptable, clear the Auto tolerance check box in the Rover options screen and enter the values that you want to use.*
- *Coordinates measured in surveys using the Trimble CenterPoint RTX service are stored in the ITRF-2008 epoch 2005.0 reference frame. When you start an RTX survey, you must select a tectonic plate if you have not already done so for that job. The receiver uses the tectonic plate that you select to compute the ITRF 2008 epoch 2005.0 coordinates from ITRF 2008 current epoch coordinates used by the Trimble RTX network, using a tectonic plate motion model embedded in its firmware.*
- *You can use a site calibration to refine the transformation between the RTX reference frame and your local coordinate system.*
- *QuickStart points **must** be able to be expressed in terms of the RTX reference frame. This means that they have either been previously measured using the CenterPoint RTX correction service, or that there is a current precisely computed RTX to RTK offset in the job, or that the job has been site calibrated in terms of RTX.*
- *If you are using an RTX (SV) survey with hourly blocks purchased for the RTX correction service, an "End RTX tracking to stop subscription timer?" message appears when you end the survey. Select Yes to disable the RTX SV tracking in the receiver. When you start a new survey using the RTX service, you will need to wait for the solution to re-converge. If you wish*

to start another survey in a relatively short period of time after ending the current survey, and you don't want to wait for the RTX solution to re-converge, select No. Selecting No means your RTX subscription will continue to use time even though you are not in a survey, but the next survey will start with a converged solution if RTX and GNSS tracking is maintained between surveys. For RTX (Internet) surveys using hourly blocks purchased for the RTX correction service, the software stops using the RTX correction service as soon as you end the survey because the Internet connection is automatically disconnected.

- *To use the CenterPoint RTX correction service, the Trimble R10 receiver must have receiver firmware version 4.83 or later; the Trimble NetR9 Geospatial receiver must have receiver firmware version 4.92 or later.*
- *To process Trimble Access job files with RTX data in Trimble Business Center, you must have version 2.95 (32-bit) or 3.10 (64-bit) or later.*
- *In an RTX survey, the Reset button on the satellite plot/list screen resets SV tracking as well as RTX convergence. The Reset button on the RTX status screen resets the RTX convergence but not the satellite tracking.*
- *The RTX status screen shows the current Correction satellite name. To select a different satellite, tap Options and then select the required satellite from the list. Alternatively, select Custom and then enter the frequency and bit rate to use. Changes you make to the settings are used the next time you start a survey. You can change the correction satellite at any time; changing the correction satellite does not require restarting the survey.*
- *The Trimble RTX subscription expiry date is displayed in the Instrument / Receiver settings screen.*
- *Trimble RTX subscriptions which have been purchased as blocks of hours operate within a validity window, which is the start date and end date between which the number of hours/minutes purchased must be used.*

For more information, go to www.trimble.com/positioning-services.

Combining RTK and RTX in the same job

All GNSS data within a single Trimble Access job must be in the same reference frame. This is the reference frame of the RTK base station(s) or network RTK reference frame used in the job.

The simplest way to combine RTK and RTX data in the same job is to perform the RTK survey in the RTX reference frame, which in Trimble Access is ITRF-2008 epoch 2005.0. This is done by setting up your RTK base on a point that has been measured precisely using CenterPoint RTX correction service, or is known precisely in that reference frame. You cannot combine RTX data and network RTK data in this manner unless the RTK network is broadcasting base data that is in the ITRF-2008 epoch 2005.0 reference frame.

Note - *You cannot use a site calibration to combine RTX and RTK data since a site calibration creates a transformation from the single GNSS reference system to the single local reference system, not from one GNSS reference system to another. However, if you have combined RTX and RTK by setting up your RTK base on a precise RTX point, you could then calibrate the RTX/RTK data to a local reference frame.*

Trimble Access allows RTK data that is not in terms of the RTX reference frame to be combined with RTX data in the same job by using an **RTX-RTK offset**. These offsets are computed from a precise RTK point and a precise RTX point in the same physical location, and that difference is applied to all

measured RTX points to bring them into terms with the RTK data in the job. The raw RTX measurements are stored, and the offset is applied when viewing coordinates or before performing any operations on those RTX measurements such as cogo calculations and stakeout.

When performing a site calibration using RTX measurements when there is an RTX-RTK offset in the job, the offset is applied to bring the RTX measurements into terms with the RTK data before calculating the site calibration. Trimble recommends that you finalize a very precise RTX-RTK offset for the job before performing a site calibration using RTX measurements.

When an RTX-RTK offset is applied to a job, the precision estimates of the RTX measurements are inflated by the precision of the RTX-RTK offset using the propagation of variances principle. The precision of the latest offset in the job is applied to all displayed and stored RTX measurements in the job. When the offset is updated, the precision of the new offset is reapplied to all RTX point measurements in the job.

WARNING - Take great care to avoid changing the offset already in a job to a less precise offset, as this action may cause the precision of the points stored in the job to no longer meet the precision tolerances applied when the points were measured.

Computing an RTX-RTK offset

To compute an RTX-RTK offset, the Trimble R10 receiver must have receiver firmware version 4.83 or later. To import Trimble Access job files with RTX-RTK offsets into Trimble Business Center, you must have TBC version 2.99 (32-bit) or 3.30 (64-bit) or later.

1. From the main General Survey menu, tap *Measure* and then tap *RTX-RTK offset*.
2. In the *RTK point* field, select a point. This must be a point measured using RTK.
3. In the *RTX point* field, select or measure an RTX point. This must be a point measured using the CenterPoint RTX correction service.

The offset is computed immediately when the two point fields are completed.

4. Review the results of the offset computation. If acceptable, tap *Store* to commit the offset to the job.

Note - *The precision of the offset and therefore the precision of the RTX points reduced into the RTK reference frame depends on the precision of the measured RTK and RTX points used to compute that offset. You **must** use the most precise point measurements possible to compute the offset.*

To remove an RTX-RTK offset, view the offset in the *RTX-RTK offset* screen and then tap *None*. Tap *Yes* to confirm. The value of the offset is changed to zero.

Satellite-based augmentation system (SBAS)

SBAS signals provide real-time, differentially corrected positions without the need for a radio link. You can use SBAS in real-time surveys when the ground-based radio link is down.

To use SBAS signals, in the *Rover options* screen of your survey style, set *Satellite differential* to SBAS. In real-time differential surveys, you can set the broadcast format to SBAS to always store SBAS positions without the need for a radio link.

For real-time differential surveys where the rover can track the QZSS signals, select *SBAS* in the *Broadcast format* field, and select the *QZSS* option. This enables the rover receiver to track the

QZSS satellite and, if you are within the valid QZSS differential network, to use the QZSS SBAS differential corrections in the real-time differential survey.

When SBAS signals are being received, the radio icon changes to a SBAS icon, and in an RTK survey, RTK:SBAS is displayed on the status line.

In an SBAS survey, QC1 quality control information is available, while QC2 and QC3 are not available.

The availability of SBAS signals depends on your location. For example:

- WAAS is available in the Americas.
- EGNOS is available in Europe.
- MSAS and QZSS are available in Japan.

OmniSTAR differential correction service

OmniSTAR® is a wide-area differential GPS service provider. OmniSTAR correction signals are proprietary, are available worldwide, but are only supported by an OmniSTAR capable GNSS receiver and a subscription must be bought from OmniSTAR to receive a subscription authorization.

OmniSTAR signals provide real-time, differentially corrected positions without the need for a radio link. You can use OmniSTAR:

- for [RT differential surveys](#)
- for fallback in an [RTK survey](#) when the ground-based radio link is down

Subscription levels for OmniSTAR corrections include:

- OmniSTAR HP, G2 and XP - all three are displayed in Trimble Access as OmniSTAR HP
- OmniSTAR VBS - displayed in Trimble Access as OmniSTAR VBS

In an OmniSTAR survey, QC1 quality control information is available, while QC2 and QC3 are not available.

Notes

- *For SBAS/OmniSTAR surveys, you must use a GNSS receiver that can track SBAS/OmniSTAR satellites.*
- *To track OmniSTAR satellites, start a survey using a style that specifies OmniSTAR as the Satellite Differential service. Once you end that survey, subsequent surveys will track OmniSTAR satellites until you start a new survey with a style that does **not** specify OmniSTAR for the Satellite differential.*
- *The OmniSTAR subscription expiry date is displayed on the OmniSTAR initialization screen or from the Instrument / Receiver settings screen.*
- *OmniSTAR is only available in the Trimble R7-GNSS with firmware 4.60 or later, and in the Trimble R10 receiver.*
- *To process Trimble Access job files with OmniSTAR data in Trimble Business Center, you must have version 2.70 or later.*
- *See your local Trimble distributor for more information.*

OmniSTAR - RTK survey

To survey using RTK and OmniSTAR do this:

1. Create an RTK survey style with the satellite differential set to OmniSTAR. See [Rover and base options](#).

2. Start an RTK survey using this survey style.

The *Select OmniSTAR Offset* screen appears.

To relate the OmniSTAR positions to the RTK positions, you must measure the *OmniSTAR offset* between an RTK measured point and the same position measured using OmniSTAR. Before the offset can be measured, you must wait for the OmniSTAR survey to converge.

Tip - The following techniques enable you to survey without the convergence delay.

- You can choose to measure the *OmniSTAR offset* later when the OmniSTAR system has converged. To do this:
 - a. Tap *Esc* and continue surveying using RTK.
 - b. To check to see if the OmniSTAR survey has converged tap *General Survey / Measure / OmniSTAR initialization*.
 - c. When the OmniSTAR survey has converged, tap *Offset* and then measure the *OmniSTAR offset*. See steps 4 to 10 below.
- You can initialize your OmniSTAR survey enabling you to continue surveying using the OmniSTAR signals if the ground-based radio link goes down during an RTK survey. See [Initializing an OmniSTAR survey](#) below.

3. Tap *New*.

4. From the *Initialization point* field select a previously measured point.

Tip - Trimble recommends selecting the highest quality, most convenient RTK point.

5. Define the antenna.

6. Optionally, enter a note.

7. With the survey receiver positioned at the *Initialization point* tap *Start* to measure the point.

When the measurement is complete, the Trimble Access software computes the offset between the OmniSTAR position and the initialization point and applies this offset to the subsequent OmniSTAR corrected positions from the GNSS receiver, ensuring that the OmniSTAR positions are in terms of the RTK points.

When OmniSTAR signals are being received, the radio icon changes to an SBAS icon , and RTK:OmniSTAR appears on the status line.

Tips

- Tap  to see the SBAS status. From the *SBAS status* screen, tap the *Info* softkey to see the OmniSTAR initialization details. The *Info* softkey is only available when you are in a survey.
- Tap the *Data link* softkey from the *SBAS status* screen to access the [Rover radio](#) screen.

8. Continue surveying.

If the ground-based radio link goes down during an RTK survey you can continue surveying using the OmniSTAR signals.

For subsequent RTK surveys using OmniSTAR and the same RTK base as before, you do not need to measure a new *OmniSTAR offset*. When you start the survey you will be presented with a list of previously measured offsets for the current base. Select an appropriate offset.

Tips

- Tap *All* to see all previously measured offsets for all bases and then *Filter* to filter the list to display the offsets for the current base. You must select an offset for the current RTK base, or for another base that is in the same calibration. Tap *Delete* to delete an offset. Tap *Clear* to clear a previously selected offset.
- The selected offset is indicated by a tick.

Starting an OmniSTAR survey on its own

If you can't start an RTK survey you can start an OmniSTAR survey on its own. To do this:

1. Attempt to start an RTK survey configured to use the OmniSTAR system when RTK is unavailable.
2. Tap *Esc*. You will be asked if you want to cancel the survey or start an OmniSTAR survey without waiting for RTK.
3. Tap *Continue* to start an OmniSTAR survey.
4. Select an OmniSTAR offset.

Note - Because you have not received an RTK base yet, the offset list can not be filtered. You must select an offset with the appropriate base.

Tip - The selected offset is indicated by a tick.

5. Continue surveying

Later, if you are within radio range and the RTK base is detected, a *New base detected* message appears, enabling you to select the base and continue surveying using RTK.

Initializing an OmniSTAR survey

If you start a survey without RTK, or if the ground-based radio link goes down during an RTK survey and you lose lock on satellites resulting in OmniSTAR losing convergence, you can manually initialize the OmniSTAR system. To do this:

1. Tap *General Survey / Measure / OmniSTAR initialization*.
2. If you have not already done so, select an offset.

Tip - The selected offset is indicated by a tick.

3. Tap *Init*.
4. From the *Initialization point* field, select a previously measured point.

Tip - Trimble recommends that you select the highest quality, most convenient RTK point.

5. Define the antenna.

- With the survey receiver positioned at the *Initialization point*, tap *Start* to measure the point. The OmniSTAR system will converge.

Notes

- This procedure is only available for OmniSTAR HP, G2 and XP subscription levels.*
- If your RTK survey is running and an OmniSTAR offset is selected, OmniSTAR can initialize from the RTK survey automatically and this procedure is not necessary.*
- Tap  to see the SBAS status. From the SBAS status screen, tap the Info softkey to see the OmniSTAR initialization details. The Info softkey is only available when you are in a survey.*
- The SBAS status screen shows the current Correction satellite name. To select a different satellite, tap Options and then select the required satellite from the list. Alternatively, select Custom and then enter the frequency and bit rate to use. Changes you make to the settings are used the next time you start a survey. You can change the correction satellite at any time; changing the correction satellite does not require restarting the survey.*

OmniSTAR - RT differential survey

To survey using RT differential and OmniSTAR do this:

- Create an RT differential survey style with the broadcast format set to OmniSTAR. See [Rover and base options](#).
- Start an RT differential survey using this survey style.

When OmniSTAR signals are being received (and not RTK), the radio icon changes to an SBAS icon.

Tip - Tap the SBAS icon to see the SBAS status.

Note - *If you subscribed for OmniSTAR HP, G2, or XP, the accuracy of your position after convergence will improve as the system converges.*

Starting the rover survey

Starting a real-time rover survey

The base survey must be running before you can start a rover survey. If a base survey is not already running, start the base receiver. For more information, see [Base receiver setup](#).

WARNING - If you start a survey while the receiver is logging data, logging stops. If you start a survey that specifies data logging, logging restarts to a different file.

To start a survey using VRS or FKP (RTCM), you must send an approximate position for the rover receiver to the control station. When you start the survey, this position is automatically sent through your radio communications link in a standard NMEA position message. It is used to compute the RTK corrections your receiver will use.

To start the rover receiver for a real-time survey:

1. Make sure that the required job is open. The title of the main menu should be the current job name.
2. From the main menu, choose *Measure* or *Stakeout*. Select a survey style from the list.

When you start a survey using a particular Trimble survey style for the first time, the General Survey software prompts you to customize the style for your specific hardware.

Note - If you have only one survey style, it is automatically selected.

3. Select *Start Survey*.
4. Make sure the rover is receiving radio corrections from the base.

Note - An RTK survey needs radio corrections.
5. If the receiver you are using supports transmission delays and the *Prompt for station index* check box in the *Rover options* option in the survey style is selected, the *Select base station* screen appears. It shows all the base stations operating on the frequency you are using. The list shows the station index numbers of each base and the reliability of each. Highlight the base you want to use and tap *Enter*.

For more information about using transmission delays, see [Operating several base stations on one radio frequency](#).

Tip - If you want to check the point name of the base station being used in the rover survey, select *Files / Review current job* and inspect the *Base point record*.

6. If necessary, initialize the survey using an [RTK initialization](#) method.

Note - If you are carrying out an RTK survey but do not require centimeter-level results, select *Measure / RTK initialization*. Tap *Init* and set the *Method* field to *No initialization*.

For an RTK survey, initialize before starting centimeter-level surveying. If you are using a dual-frequency receiver with the OTF option, the survey automatically starts to initialize using the *OTF initialization* method.

7. [Measure points](#).

Switching to PP infill

During periods when no base corrections are received, the following message flashes in the status line:

Radio link down

To continue surveying select *Start PP infill* from the *Measure* menu. When postprocessing infill starts, this item changes to *Stop PP infill*.

Raw data is logged at the rover during postprocessing (PP) infill. For successful baseline resolution, you must now use postprocessed kinematic observation techniques.

Note - Initialization cannot be transferred between the RTK survey and the PP infill survey. Initialize the PP infill survey like any other postprocessed kinematic survey. For more information, see [Postprocessed initialization methods](#).

Only rely on the OTF (automatic) initialization if you are certain that the receiver will observe at least six satellites, without interruption, for the next 8 minutes. Otherwise, select *Measure / PPK initialization* and perform an initialization.

Note - You cannot stake out points during a postprocessed survey.

When base corrections are received again, the *Radio link up* message appears in the status line. This message also shows the initialization mode of the RTK survey.

Select *Stop PP infill* from the *Measure* menu to stop data logging at the rover. When postprocessing infill stops, this item changes back to *Start PP infill*. Real-time measurements are resumed.

Starting a postprocessed rover survey

To start the rover receiver for a postprocessed survey, select *Start survey*.

You can begin surveying immediately, you do not need to initialize a [FastStatic](#) or [RT differential survey](#).

You must initialize a PP kinematic survey to achieve centimeter-level precisions when the data is processed. With dual-frequency receivers, the initialization process begins automatically if at least five L1/L2 satellites are being observed.

For more information about initializing a postprocessed survey, see [Postprocessed initialization methods](#). For information about measuring points, see [Measure points](#).

Working with no initialization

If you do not want to initialize a survey, start the survey and then select *PPK initialization*. When the *PPK initialization* screen appears, press *Init*. Set the *Method* field to *No initialization* and then tap *Enter*.

Initialization

For an RTK survey, initialize before starting centimeter-level surveying. If you are using a dual-frequency receiver with the OTF option, the survey automatically starts to initialize using the *OTF initialization* method.

You must initialize a PP kinematic survey to achieve centimeter-level precisions when the data is processed. With dual-frequency receivers, the initialization process begins automatically if at least five L1/L2 satellites are being observed.

RTK initialization methods

If base corrections are being received and there are sufficient satellites, the survey is initialized automatically when you start the survey. A survey must be initialized before centimeter-level surveying can begin.

To re-initialize RTK while roving, set the *Method* to *Reset RTK* (R10 receiver only) or *On the fly* and then tap *Reset* or *Start*. The receiver re-initializes RTK. To drop all SV tracking, re-acquire the SVs, and re-initialize RTK, set the *Method* to *Reset SV tracking* and then tap *Reset*.

In the past, you might have used an "antenna dump" (tipping the rod upside down) to lose lock on the satellites in order to obtain an independent set of measurements before and after. With today's tracking performance improvements, dumping the antenna often does not lose lock.

Dumping the antenna is not recommended, instead use the *Reset SV tracking* function to perform the equivalent of an antenna dump. Resetting SV tracking is not recommended in difficult GNSS environments, instead use *Reset RTK* or *On the fly*. In difficult GNSS environments, retaining satellite signal tracking for some time can result in better performance than using re-acquired signals.

The number of satellites required depends on whether you are using GPS satellites only, or a combination of GPS and GLONASS satellites. The following table summarizes the requirements.

Minimum L1/L2 satellites required for initialization

Satellite systems	Required satellites
GPS only	5 GPS
GPS + QZSS	4 GPS + 1 QZSS
GPS + GLONASS	4 GPS + 2 GLONASS
GPS + BeiDou	4 GPS + 2 BeiDou
GPS + Galileo	4 GPS + 2 Galileo
BeiDou only	5 BeiDou
BeiDou + GPS	4 BeiDou + 2 GPS
BeiDou + GLONASS	4 BeiDou + 2 GLONASS
GLONASS only	N/A
Galileo only	N/A

Note - You cannot initialize if the PDOP is greater than 7.

After initialization, a position can be determined and the initialization can be maintained with one satellite less than the number required to initialize. If the number of satellites drops below this number, the survey must be reinitialized.

The following table summarizes the requirements.

Minimum L1/L2 satellites required to maintain initialization and produce positions

Satellite systems	Required satellites
GPS only	4 GPS
GPS + QZSS	3 GPS + 1 QZSS
GPS + GLONASS	3 GPS + 2 GLONASS
GPS + BeiDou	3 GPS + 2 BeiDou
GPS + Galileo	3 GPS + 2 Galileo
BeiDou only	4 BeiDou
BeiDou + GPS	3 BeiDou + 2 GPS
BeiDou + GLONASS	3 BeiDou + 2 GLONASS
GLONASS only	N/A
Galileo only	N/A

With legacy receivers, after initialization, the survey mode changes from Float to Fixed. The mode remains Fixed if the receiver continuously tracks at least four satellites. If the mode changes to Float, reinitialize the survey.

With new GNSS receivers, after initialization, the survey mode changes from *Not initialized* to *Initialized*. The mode remains *Initialized* if the receiver continuously tracks the minimum number of satellites. If the mode changes to *Not initialized*, you must reinitialize the survey.

Multipath

Initialization reliability depends on the initialization method used and on whether or not multipath occurred during the initialization phase. Multipath occurs when GNSS signals are reflected off objects, such as the ground, a building, or trees. When initializing, always choose a site that has a clear view of the sky and is free of obstructions that could cause multipath.

The occurrence of multipath at the GNSS antenna adversely affects GNSS initializations and solutions:

- If initialization is by the Known Point method, multipath can cause an initialization attempt to fail.
- During initialization by the OTF method, it is difficult to detect multipath, which may cause initialization to be lengthy or unsuccessful.

The initialization process in Trimble receivers is very reliable. In legacy receivers, if an incorrect initialization does occur, the Trimble RTK processing routines detect it very quickly, discard the initialization automatically and the Trimble Access software then displays a warning. In receivers equipped with HD-GNSS technology, incorrect initializations are more reliably prevented from occurring, and the precision estimates better reflect the multipath conditions.

Notes

- *You should adopt good survey practice and periodically check your initialization by measuring previously measured points with a new initialization.*
- *To minimize the effect of multipath during an OTF initialization, move around.*

Known Point initialization

To perform a Known Point initialization:

1. Position the rover antenna over a known point.
2. From the *Measure* menu, tap *RTK initialization*.
3. Set the *Method* field to *Known Point*.

Tip - To re-initialize RTK while roving, set the *Method* to *Reset RTK* (R10 receiver only) or *On the fly* and then tap *Reset* or *Start*. The receiver re-initializes RTK. To drop all SV tracking, re-acquire the SVs, and re-initialize RTK, set the *Method* to *Reset SV tracking* and then tap *Reset*. Resetting SV tracking in compromised GNSS environments is not recommended.

4. Access the *Point name* field and tap *List*. Select the point from the list of known points.
5. Enter values in the *Antenna height* field, and make sure that the setting in the *Measured to* field is correct.

- When the antenna is centered and vertical over the point, tap *Start*.

The controller starts to record data, and the static icon () appears in the status bar. Keep the antenna vertical and stationary while data is recorded.

Tip - If you are using a GNSS receiver with an in-built tilt sensor, tap *eBubble* (or press **Ctrl + L**) to display the eBubble. When the bubble is green, tap *Start* to ensure that the point is measured within the predefined tilt tolerance. The tolerance is that specified for a [Topo point](#).

- When the receiver is initialized, a message stating this appears together with the deltas from the RTK position to the known point. Tap *Accept* to continue.
- If the initialization fails, the results are displayed. Tap *Retry* to retry the initialization.

Postprocessed initialization methods

In a postprocessed survey you must initialize to attain centimeter-level precisions.

Use one of the following methods to initialize dual-frequency postprocessed kinematic surveys in the field:

- On-The-Fly
- Known Point

Note - In a postprocessed survey, collect enough data during initialization so that the postprocessor can successfully process it. Recommended times are as follows.

Initialization method	4 SVs	5 SVs	6+ SVs
L1/L2 on-the-fly initialization	N/A	15 min	8 min
L1/L2 new point initialization	20 min	15 min	8 min
Known Point initialization	at least four epochs		

After initialization, the survey mode changes from *Not initialized* to *Initialized*. The mode remains *Initialized* if the receiver continuously tracks the minimum number of satellites. If the mode changes to *Not initialized*, you must reinitialize the survey.

Note - If you do an *On-The-Fly* initialization in a postprocessed kinematic survey, you can measure points before initialization is gained. The Trimble Business Center software can back-process the data later to give a centimeter-level solution. If you do this but lose lock on the satellites while initializing, re-measure any one of the points that you surveyed before lock was lost.

Known Point initialization

In a postprocessed survey you can initialize on:

- a point measured previously in the current job
- a point that you will provide coordinates for later (before the data is postprocessed)

See [Known Point initialization](#) for instructions.

Starting a real-time survey using a dial-in connection

If you are receiving corrections from a single base station, do not start the survey until you have started the base receiver.

To start the rover receiver for a real-time survey:

1. If you are using a cellular modem, make sure that the modem is switched on and then connect it to the receiver (or to the controller if you selected the *Route through controller* option).
2. If you are using a Trimble Internal GSM module, make sure that the receiver is turned on and is connected to the controller.
3. From the main menu, tap *Measure / <Style name> / Measure points*.

The message *Connecting to modem* appears. Once the connection is set up, the modem dials the base station or wide-area RTK service provider. When the call is connected, and the corrections data link is established, the cellular phone icon appears on the status bar.

Tip - Select the *Prompt for GNSS contact* check box to display the GNSS contact that is configured in the survey style, or change the GNSS contact when you start the survey.

To end the survey, tap *Measure / End GNSS survey*. The modem hangs up during the end survey process.

Note - When you send initialization strings to the modem, if you see the error message "No response from modem", check that the strings you set in the survey style are valid for your particular modem. Some modems accept only upper case AT commands.

Note - To configure a survey style to use a dial-in data link, see [Configuring a dial-in data link](#).

Starting a real-time survey using a mobile Internet connection

If you are receiving corrections from a single base station, do not start the survey until you have started the base receiver.

To start the rover receiver for a real-time survey:

1. If you are using a cellular modem, make sure that the modem is switched on, then connect it to the receiver.
2. If you are using a Trimble internal modem, make sure that the receiver is turned on and is connected to the controller.
3. From the main menu, tap *Measure / <Style name> / Measure points*
4. If the *Prompt for GNSS contact* check box is selected in your survey style, select a GNSS contact to use.

The message "Establishing network connection" appears.

5. If *Connect directly to Mountpoint* and the NTRIP Mountpoint name were configured in the GNSS contact, you are not prompted to select one from the Source Table.

If *Connect directly to Mountpoint* was not selected, or the *NTRIP Mountpoint* name was not configured, or the defined Mountpoint cannot be accessed, the Source Table appears. Select the Mountpoint you want to receive corrections from.

Once the corrections data link is established, the radio icon appears on the status bar. Once the connection is completed, the modem receives corrections from the base station or wide-area RTK service provider through the Internet connection.

Notes

- To configure a survey style to use an Internet data link, see [Configuring an Internet data link](#).
- If you are using a Geo7X/GeoXR controller and the Trimble Access software changes the mode of the internal modem when you start the survey, then the current "3G/GSM Selection" displayed in the controller operating system may be incorrect.
- When you start a survey with the controller already connected to the Internet, the existing connection is used for the base data. The Internet connection does not close when you end the survey.

When you start a survey with the controller not connected to the Internet, the controller will open an Internet connection using the connection specified in the Survey Style. This connection closes when you end the survey.

Redialing the base station

If you lose the cellular modem connection when using a dial-in or Internet data link, use *Redial* to re-establish the connection to the base station or [wide-area RTK network](#).

Alternatively, you can hang up the modem using the General Survey software, continue the survey, and later redial the base to re-establish corrections.

To hang up and redial a dial-in connection:

1. Tap the cellular modem icon on the status bar. The *Rover data link* screen appears.
2. To hang up the modem, tap *Hang up*.
3. To redial the base station, tap *Redial*.

To hang up and redial a mobile internet connection:

1. Tap the network connection icon on the status bar. The *Rover data link* screen appears.
2. To hang up the network connection, tap *Hang up*.
3. To redial the base station, tap *Redial*.

Notes

- A mobile Internet connection can be hung up in the *Rover data link* screen only when the connection was established when you started the survey. However, you can always redial the connection from within the *Rover data link* screen while the survey is running.
- When you redial a VRS service provider, a new VRS base station position is sent through the data link. The General Survey software switches to the new base, and the survey continues.

Ending the rover survey

When you have measured or staked out all points required, do the following:

1. From the *Measure* or *Stakeout* menu, choose *End GNSS survey*.
When prompted to power down the receiver, tap *Yes*.
2. Turn off the controller **before** disconnecting the equipment.
3. Return to the base station and end the base survey. For more information, see [Ending a base survey](#).

GNSS Survey – Measure

Measuring points in a GNSS survey

The *Measure* screen lets you record points measured using data from the connected GNSS instrument. For information on setting up the instrument, see [GNSS survey – Getting started](#).

To access the *Measure* screen, from the main menu tap *Measure*.

To measure points, select *Measure points* then select the appropriate measurement method from the *Method* field.

The types of points that you can measure depend on your survey style and the survey method used.

In real-time GNSS surveys, the following methods are available:

Select...	To...
Topo point	measure a point
Compensated point	measure a point using an unlevelled pole with a Trimble R10 receiver, and have the antenna's offset location corrected to produce a ground position at the tip of the pole.
Observed control point	measure a point with an extended occupation time and quality control information.
Calibration point	measure a point during site calibration.
Rapid point	quickly measure a point with no minimum occupation time.

Note - If you have turned off *Tilt* in the *Rover Options* form or set the *Broadcast format* to *RTX* when configuring the survey style, then the *compensated point* measurement method is not available.

In postprocessed GNSS surveys, the following methods are available:

Select...	To...
Topo point	measure a point
Observed control point	measure a point with an extended occupation time and quality control information.
FastStatic	measure a point without tracking satellites between points.

To measure a line of points at a fixed distance, fixed time, or distance and time interval, or to measure points along with depths using an echo sounder, select *Continuous topo* in the *Measure* screen.

To measure points with feature codes, select *Measure codes* or *Measure topo* in the *Measure* screen.

Note - You cannot measure a compensated point or use continuous topo if you are in an RTX survey.

Occupation warnings

During a point measurement the General Survey warns you if there are adverse conditions that result in any of the tolerances being exceeded and prevent the point being stored. The *Confirm and store point?* screen lists all issues that occurred during the measurement, in order of priority.

Tap *Yes* to store the point, tap *No* to not store the point. To re-measure the point, tap *Re-Measure*.

Note - No warnings appear when you are measuring a *Rapid point*.

- When you press *Measure* and the eBubble is outside the tilt tolerance (the bubble is red) a *Receiver not level, measure anyway?* message appears. Tap *Yes* to continue measuring the position.
- You can tap the  button to accept the measurement before the occupation time or precisions have been satisfied or while there are conditions preventing point storage.

Notes

- Two behaviors are supported when measuring a position with **excess tilt** or **excess movement**.
 - **Automated behavior:** Use the *Auto abandon* option for *Topo point* and *Observed control point*. When selected, points measured using a GNSS receiver with an in-built tilt sensor that experience excess tilt, or, for all receivers, excess movement, during the measurement process are abandoned. To re-measure the point you must manually start measuring the point again, unless you are measuring a *Topo point* with *Tilt Auto-measure* enabled, in which case the software will return you to the "Waiting for level" state so no manual interaction is needed.
 - **Manual behavior:** Use the *Re measure* option to discard the current point and re-measure the point.
- The **Position compromised** warning appears when the receiver is in static mode measuring a point and a new GNSS position is different from the immediately previous GNSS position by more than the current 3-sigma precision estimates. This warning appears only when the difference in position is larger than the current precision tolerances, and if the GNSS receiver does not produce excess movement warnings of its own during the occupation. The position compromised warning can occur in severely marginal GNSS environments where there is a lot of multipath or signal attenuation. The QC1 occupation warnings information enables you to tell if this happened while observing a point stored in the database.

GNSS messages

To discard GNSS messages and prevent them re-appearing, tap **Ignore** in the message. For non-RTX messages, the message is discarded and does not appear again. For Trimble RTX correction service messages, only messages regarding the same subscription status are ignored; if the subscription status changes then the Ignore setting is reset and messages appear. Tapping **Ignore** is controller-specific; if you use the same GNSS receiver with a different controller then the Ignore setting for that controller is used and the messages may reappear.

Other ways to measure a point

The General Survey software also enables you to:

- [Capture panoramas when measuring points](#) if the controller is connected to a Trimble V10 imaging rover.
- Measure and store a [check point](#).
- Measure and automatically store a construction point. For more information, see [Fast fix](#).
- [Measure points using a laser rangefinder](#).

Reviewing stored points

To review stored points, select *Review job* from the *Jobs* menu.

Tip - In *Point name* fields there is a *Find* softkey that lets you search for the next available point name. For example, if your job contains points numbered in the 1000s, 2000s and 3000s, and you want to find the next available point name after 1000:

1. In the *Point name* field, tap *Find*. The *Find next free point name* screen appears.
2. Enter the point name you want to start searching from (in this example, 1000) and tap *Enter*.

The General Survey software searches for the next available point name after 1000 and inserts it in the *Point name* field.

Topo point

This is a previously configured method of measuring and storing a point.

Configure [settings for this measurement method](#) in your [survey style](#) or tap *Options* in the *Measure points* screen.

Measuring a topo point in a GNSS survey

You can measure a topo point in every type of survey except a FastStatic survey.

1. Do one of the following:
 - From the main menu, select *Measure / Measure points*
 - Tap *Favorites* and select *Measure point*
 - From the Map, select *Measure* (only available when nothing in the map is selected).

To automatically start the measurement when you select *Measure* from the map, tap *Options* and then select the *Auto measure* check box.

2. Enter values in the *Point name* and *Code* fields (the *Code* field entry is optional), and then select *Topo point* from the *Method* field.
If the code has attributes, see [Using feature codes with predefined attributes](#).
3. Enter a value in the *Antenna height* field and make sure that the setting in the *Measured to* field is set appropriately.
4. If you have not already done so: tap *Options* to:
 - Configure the quality control, precision, and [tilt settings](#).
 - Select *Add vertical offset*, if required. Then in the *Measure points* screen, enter a value in the *Vertical offset* field.
5. When the antenna is vertical and stationary, tap *Measure* to start recording data. The static icon appears in the status bar.
Tip - You can tap *Enter* to accept the measurement before the occupation time or precisions have been satisfied.
6. When the preset occupation time and precisions have been reached, tap *Store*.

Tips

- When using a GNSS receiver with an in-built tilt sensor, you can configure the survey style to prompt a warning when the pole is outside a specified [Tilt tolerance](#). When measuring a point, the *eBubble* appears. Store the point when the bubble is within the tilt tolerance.
- Select the *Auto store point* check box to automatically store the point when the preset occupation time and precisions have been met.
- You can use the Trimble V10 imaging rover to [capture panoramas when you measure a point during a GNSS survey](#).

Tilt auto-measuring a topo point in a GNSS survey

To [Tilt auto-measure](#) a topo point you must use a GNSS receiver with an in-built tilt sensor and [define a suitable survey style](#).

1. Do one of the following:
 - From the main menu, select *Measure / Measure points*
 - Tap *Favorites* and select *Measure points*
 - From the Map, select *Measure* (only available when nothing in the map is selected).
To automatically start the measurement when you select *Measure* from the map, tap *Options* and then select the *Auto measure* check box.
2. Enter values in the *Point name* and *Code* fields (the *Code* field entry is optional) and then select *Topo point* in the *Method* field.
3. Enter a value in the *Antenna height* field and make sure that the setting in the *Measured to* field is set appropriately.
4. Tap *Options* to configure the quality control, precision and [tilt settings](#).

5. Tap *Start*. The eBubble will automatically display and *Waiting for level* will display in the status line.
6. When the receiver is within the specified tilt tolerance, the position will auto-measure. The static icon appears in the status bar.
7. When the preset occupation time and precisions have been reached, tap *Store*.
8. The status line updates to display *Waiting to move*. You can now move to the next point to be measured. When movement of more than 5 degrees of tilt is detected the status line updates to display *Waiting for level*. The system is now ready to measure the next point.
9. To exit the *Tilt auto-measure* process press *End*.

Compensated point

The *Compensated point* measurement method allows you to measure points with an unlevelled pole with a Trimble R10 receiver, and have the antenna's offset location corrected to produce a ground position at the tip of the pole.

Compensated points are useful when:

- You want to speed up your workflow without spending time making sure the pole is level.
- An obstruction means that you are unable to position the antenna directly above the point. Traditionally you would need to use an offsetting technique to measure such points.

To measure compensated points, the Trimble R10 receiver must have receiver firmware version 4.83 or later. To import Trimble Access job files with compensated points in Trimble Business Center, you must have TBC version 2.95 (32-bit) or 3.10 (64-bit) or later.

Configure [settings for this measurement method](#) in your [survey style](#) or tap *Options* in the *Measure points* screen.

Measuring a compensated point in a GNSS survey

Before measuring compensated points you must calibrate the tilt sensor and magnetometer in the GNSS receiver. See [eBubble calibration](#) and [Magnetometer calibration](#).

Note - For best horizontal accuracy, Trimble recommends you calibrate the magnetometer each time you replace the battery in the GNSS receiver.

1. Start a GNSS survey and then go to the *Measure point* screen.
2. Enter a value in the *Point name* field (and *Code* field if required), and then select *Compensated point* from the *Method* field.
3. Enter a value in the *Antenna height* field and make sure that the setting in the *Measured to* field is set appropriately.
4. Tap *Options* to configure the quality control and precision settings.

Note - The precisions shown reflect the amount of tilt of the antenna. If measuring points with large amounts of tilt, you may need to increase the precision tolerance setting.
5. Position the antenna and make sure it is stationary.
6. The eBubble shows the amount of tilt of the antenna. For more information, see [Using a GNSS](#)

[receiver with an in-built tilt sensor and magnetometer.](#)

Note - An "Excess tilt" message appears in the status bar and the eBubble turns red if the tilt exceeds 15 degrees. If you can, level up the antenna so there is less tilt. If you are unable to decrease the tilt to less than 15 degrees, perform an [offset measurement](#) instead.

7. Tap *Measure*. The compensated point icon appears in the status bar. The eBubble changes to help you hold the antenna stationary.

Tip - You can tap *Enter* to accept the measurement before the occupation time or precisions have been satisfied.

8. When the preset occupation time and precisions have been reached, tap *Store*.

Tip - To speed up your workflow, enable one or both of the following options:

- To start measuring automatically when the receiver is within a specified tilt tolerance, enable the *Tilt auto-measure* option. For more information, see [Using a GNSS receiver with a built-in tilt sensor and magnetometer.](#)
- To automatically store the point when the occupation time and precisions have been reached, enable the *Auto store* option.

Magnetic disturbance

The *Compensated point* measurement method uses the tilt sensor and magnetometer built into the Trimble R10 receiver to compute the position of the pole tip. The performance of any magnetometer is affected by nearby metal objects (for example, vehicles or heavy machinery) or objects that generate magnetic fields (for example, high voltage overhead or underground power lines).

The system attempts to detect the amount of magnetic disturbance in the environment by comparing the sensed magnetic field with the expected magnetic field. The expected magnetic field comes from a model of the earth's magnetic field stored in the receiver. The magnetometer senses the magnitude (strength) and the vertical direction (inclination angle) of the environment's magnetic field and compares it to the expected magnitude and vertical direction for the location. If the values do not match, then magnetic disturbance is detected.

The level of magnetic disturbance is indicated by the Magnetic disturbance value, which uses a scale from 0 to 99. The level of magnetic disturbance is also reflected in the precision estimate. If you have correctly calibrated the magnetometer and are working in an environment free of magnetic interference, then you should see magnetic disturbance values lower than 10.

If the value is higher than 50, a warning is displayed on the status line. If the value is 99 you will not be able to store the point unless the pole's tilt distance is within 1 cm of level. Check the vicinity for sources of magnetic interference. If there are no obvious sources of magnetic disturbance, check your calibration.

You can view the magnetic disturbance value for a point in the *Review Job* screen.

WARNING - In magnetically disturbed environments it is possible for the magnetometer to sense the expected magnitude and vertical direction values but an incorrect horizontal direction. It is impossible to detect this. If this happens, the software reports low magnetic disturbance values when in fact there are large magnetic azimuth errors. To avoid these errors, it is important to use compensated points only in areas free of magnetic disturbance.

Tip - Only the horizontal position is dependent on the magnetometer. If your survey requires high vertical accuracy but horizontal accuracy is less important, then magnetic interference may be less significant. The horizontal quality of the point degrades more at a higher tilt angle with higher magnetic disturbance. In other words, magnetic disturbance has no effect if the pole is level.

Using a GNSS receiver with a built-in tilt sensor and magnetometer

A GNSS receiver with an in-built tilt sensor has the following features:

- Tilt auto-measure
- Tilt warnings
- eBubble display

See also: [eBubble calibration](#) and [Magnetometer calibration](#).

Tilt auto-measure

Tilt auto-measure enables a *Topo point*, *Compensated point*, or *Rapid point* to be auto measured when the pole is within a predefined **tilt tolerance**. When surveying using this measurement option an *eBubble*, (electronic bubble) is displayed.

Enabling tilt auto-measure

1. *Settings / Survey Styles - Rover options* and select the **Tilt** option.
2. *Settings / Survey Styles* and select the **Tilt auto-measure** option and then enter a **Tilt tolerance** for topo and rapid point types or enter a **Tilt distance** for compensated points.
3. *Instrument / Receiver settings* and configure the **eBubble**.

Notes

- *Tilt auto-measure does not operate in stakeout mode.*
- *Tilt configuration is also available from Options during a survey.*
- *Once the Tilt auto-measure sequence is started, no other survey measurement or stakeout process is permitted. Similarly, if you are doing another type of measurement or stakeout, you cannot start the Tilt auto-measure sequence.*

Tilt auto-measuring a point

1. From the *Measure points* screen tap **Start** to begin the auto measure process.
2. If the pole is tilted outside of the tilt tolerance the status line will display *Waiting for level* and the *eBubble* will display red.
3. When the pole is within the tilt tolerance for more than half a second the software automatically begins measuring the point.

4. When the point is stored the status line will display *Waiting to move*. This means the system is waiting for you to tilt the pole by more than 5 degrees on your way to the next point to be measured.
5. Once the system has detected you have moved the pole the Status line will display *Waiting for level* and will automatically start another point measurement when you level the pole within the tilt tolerance.
6. To exit the *Tilt auto-measure* mode, press *End* when the status is *Waiting for level* or *Waiting to move*.

Tilt warnings

Tilt warnings is an option that can be enabled to warn you if the rod tilt in excess of the predefined [tilt tolerance](#) is detected during measurement. When tilt warnings are enabled a measurement can only be stored when the *eBubble* is green and within the tolerance circle. You can override the warning and store the point if you wish by pressing the  button.

When the Auto-abandon setting is enabled, points measured using a GNSS receiver with an in-built tilt sensor that experience excess tilt or excess movement during the measurement process are abandoned. For information, see [Measuring points in a GNSS survey](#).

Tilt warnings are supported for the following measurement methods:

- *Topo point*
- *Compensated point*
- *Observed control point*
- *Continuous points*
- Staking a *Point* with General Survey software or Land Seismic software
- Staking a *Line, Arc, or Alignment* with General Survey software.
- Staking a *Road* with Roads software.

Enabling tilt warnings

1. *Settings / Survey Styles - Rover options* and select the *Tilt* option.
2. *Settings / Survey Styles* and select the *Tilt warnings* option and enter a *Tilt tolerance* for topo, observed control, rapid and continuous point types.
3. *Instrument / Receiver settings* and configure the *eBubble*.

Notes - Tilt auto-measure and tilt warnings

- *If the eBubble is outside the tilt tolerance when you are starting to measure a topo or observed control point (the bubble is red), a Receiver not level, measure anyway? message appears. Tap Yes to continue measuring the position.*
- *An Excess tilt detected when static message appears if you have had excess tilt at any time during the measurement process.*
- *An Excess tilt message appears if you have had excess tilt at the time of storage.*
- *The eBubble is aligned to the receiver's LED panel. To operate the eBubble correctly, the LED panel must be facing you (that is, you must be looking directly at the receiver's LED panel).*

- You can specify a Tilt tolerance and not select Tilt warnings. When you do this the eBubble indicates when the receiver is within the specified tolerance but the tilt warning is not displayed.
- Tilt information is stored with every measured point provided the eBubble was calibrated at the time the point was stored. No tilt information will be stored if the eBubble was not calibrated.
- You will be forced to recalibrate the eBubble if the current temperature differs by than more than 30 degrees Celsius from the calibration temperature.

eBubble display

Tilt tolerance is defined as the distance on the ground that the tilt represents given the antenna height. If the pole is held such that the resultant distance on the ground (*Tilt distance*) is less than the tilt tolerance the eBubble will display green and the point can be measured. The *Tilt distance* is stored with the job and is available at *Review job*. The circle on the eBubble vial represents the tilt tolerance.

To display the eBubble, tap the eBubble softkey.

Bubble color	Meaning
Green	You are within the defined tilt tolerance.
Red	You are outside the defined tilt tolerance.

Note - If the eBubble is red, you can still choose to store the position. To do this, tap .

When measuring a compensated point, the graduations in the eBubble vial represent the sphere through which the antenna moves when the pole tip is stationary.

Before you start measuring, the eBubble shows the amount of tilt of the antenna. For example:



Bubble color	Tilt range	Meaning
Green	< 12 degrees	You are within the tilt tolerance for a compensated point.
Yellow	12 to 15 degrees	You are close to exceeding the tilt tolerance for a compensated point.
Red	> 15 degrees	You have exceeded the tilt tolerance for a compensated point.

When you tap *Measure*, the appearance of the eBubble changes to help you hold the antenna stationary. For example:

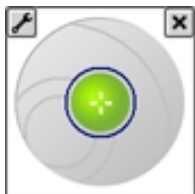

Keep the antenna as still as possible while measuring.

Tips

- To configure the eBubble, tap *Instrument / eBubble options* from the main menu, or tap the Settings icon in the top left corner of the *eBubble* window.
- To move the eBubble window to a new position on the screen, tap and hold on the eBubble and drag to a new position.
- Press **CTRL + L** to show or hide the eBubble from any screen.

Observed control point

Use the Observed control point method to measure a point with an extended occupation time and quality control information.

If the *Topo point* option is configured to perform 180 measurements, the positional result is similar to a point measured using the observed control point measurement type. Differences are:

- the default value in the *Quality control* field
- the observation class given by the office software when the point is downloaded

Configure [settings for this measurement method](#) in your [survey style](#) or tap *Options* in the *Measure points* screen.

Measuring an observed control point

1. Do one of the following:
 - From the main menu, select *Measure / Measure points*.
 - Tap *Favorites* and select *Measure points*.
2. Enter values in the *Point name* and *Code* fields (the *Code* field entry is optional), and then select *Observed control point* in the *Method* field.
3. Enter a value in the *Antenna height* field and make sure that the setting in the *Measured to* field is set appropriately.
4. Tap *Options* to configure the quality control, precision, and [tilt settings](#).
5. Tap *Measure* to start recording data.
6. When the preset number of epochs and precisions are reached, tap *Store* to store the point.

If you are using a GNSS receiver with an in-built tilt sensor and *Tilt warnings* has been selected (see [Measurement method options](#)), the *eBubble* appears. Store the point when the bubble is within the tilt tolerance.

Tips

- If the eBubble is outside the tilt tolerance (the bubble is red) a *Receiver not level, measure anyway?* message appears. Tap *Yes* to continue measuring the position.
- You can tap the  button to accept the measurement before the occupation time or precisions have been satisfied or if there has been movement, tilt, or precision warnings during the occupation.
- If you have been static measuring a point for longer than 15 epochs and the precisions go out of tolerance, a message warns that the occupation timer will reset and allows you to store the last position with good precisions. Tap *Yes* to store the last good position. Tap *No* to reset the timer and continue measuring the point.
- An *Excess tilt detected when static* message appears if you have had excess tilt at any time during the measurement process.
- An *Excess tilt* message appears if you have excess tilt at the time of storage.
- Select *Instrument / eBubble options* to configure the *eBubble*.

Note - For an RTK survey, initialize the survey before starting to measure the point. For a Postprocessed Kinematic survey, you can start measuring a point before initialization, but you should not store it until you have initialized the survey.

Rapid point

This is a method for measuring real-time GNSS points quickly. The point is stored when the preset precisions have been satisfied. There is no minimum occupation time, because the software uses a single epoch of data to define the point. This makes Rapid point the least precise measurement method.

Tip - When measuring a Rapid point, The General Survey software collects just one epoch of data when the preset precisions are reached, so the default precision values should ideally be higher than for other point measurement types.

Configure [settings for this measurement method](#) in your [survey style](#) or tap *Options* in the *Measure points* screen.

Note In an RTK and Data logging survey, points measured using the [Rapid point method](#) are not saved to the T01/T02 file and are not available for postprocessing.

Measuring a rapid point

1. Do one of the following:
 - From the main menu, select *Measure / Measure points*.
 - Tap *Favorites* and select *Measure points*.
2. Enter values in the *Point name* and *Code* fields (the *Code* field entry is optional), and then select *Rapid point* from the *Method* field.

3. Enter a value in the *Antenna height* field and make sure that the setting in the *Measured to* field is set appropriately.
4. Tap *Options* to configure the quality control, precision, and *tilt settings*.
5. Tap *Measure* to start recording data. The point is automatically stored when the preset precisions are reached.



Tip - When using a GNSS receiver with an in-built tilt sensor, you can configure the survey style to prompt a warning when the pole is outside a specified *Tilt tolerance*. When measuring a point, the *eBubble* appears. Store the point when the bubble is within the tilt tolerance.

Tilt auto-measuring rapid points

To *Tilt auto-measure* rapid points, you must use a GNSS receiver with an in-built tilt sensor, and *define a suitable style*.

1. Do one of the following:
 - From the main menu, select *Measure / Measure points*.
 - Tap *Favorites* and select *Measure points*.
2. Enter values in the *Point name* and *Code* fields (the *Code* field entry is optional), and then enter *Rapid point* in the *Method* field.
3. Enter a value in the *Antenna height* field and make sure that the setting in the *Measured to* field is set appropriately.
4. Tap *Options* to configure the quality control, precision, and *tilt settings*.
5. Tap *Start*. The *eBubble* automatically appears and *Waiting for level* appears in the status line.

Tip - Select *Instrument / eBubble options* to configure the *eBubble*.
6. When the receiver is within the specified tilt tolerance, the position will auto-measure.

If the Rapid point has 'poor precision' or 'excess tilt' or 'poor DOP' at the beginning or during the 1 second epoch, the  button appears, preventing the point from auto-storing. If the precision improves, or the pole is relevelled, then the point is stored automatically. To discard the warning and store the point, tap the  button.

Note - There are no 'Excess movement' or 'Bad GNSS Environment' checks when measuring a Rapid point.
7. The status becomes *Waiting to move*. You can now move to the next point to be measured. When movement of more than 5 degrees of tilt is detected, the status changes to *Waiting for level*. The system is now ready to measure the next point.
8. To exit the *Tilt auto-measure* sequence, press *End*.

FastStatic point

This type of point is measured in a *FastStatic survey*.

Configure *settings for this measurement method* in your *survey style* or tap *Options* in the *Measure points* screen.

Note - *FastStatic surveys are postprocessed and do not need to be initialized*.

Measuring a FastStatic point

- Do one of the following:
 - From the main menu, select *Measure / Measure points*.
 - Tap *Favorites* and select *Measure points*.
- Enter values in the *Point name* and *Code* fields (the *Code* field entry is optional).
- Enter a value in the *Antenna height* field and make sure that the setting in the *Measured to* field is set appropriately.
- Tap *Measure* to start measuring the point.
- When the preset occupation time is reached, as shown in the following table, tap *Store* to store the point.

Receiver type	4 SVs	5 SVs	6+ SVs
Single-frequency	30 min	25 min	20 min
Dual-frequency	20 min	15 min	8 min

Tip - No satellite tracking is necessary between measuring points.

Note - The occupation time counter for measuring a FastStatic point is paused when the PDOP of the satellites being tracked exceeds the PDOP mask set in the survey style being used. The counter resumes when the PDOP falls below the mask.

The number of satellites required for measuring a FastStatic point depends on whether you are using GPS satellites only, BeiDou satellites only or a combination of GPS, BeiDou, GLONASS, Galileo and QZSS satellites. The following table summarizes the **minimum** requirements:

Satellite systems	Required satellites
GPS only	4 GPS
GPS + QZSS	3 GPS + 1 QZSS
GPS + GLONASS	3 GPS + 2 GLONASS
GPS + BeiDou	3 GPS + 2 BeiDou
GPS + Galileo	3 GPS + 2 Galileo
BeiDou only	4 BeiDou
BeiDou + GPS	3 BeiDou + 2 GPS
BeiDou + GLONASS	3 BeiDou + 2 GLONASS
GLONASS only	N/A
Galileo only	N/A

Continuous topo – GNSS

Use the *Continuous topo* function to measure points continuously.

A point is stored when one of the following conditions occurs:

- a predefined time has elapsed
- a predefined distance has been exceeded
- both predefined time and/or distance settings have been met
- a predefined stop time and distance settings have been met

If you are doing a postprocessed survey, the time interval is the logging interval. Configure this logging interval in the *Rover options* screen of the postprocessed survey style.

Configure [settings for this measurement method](#) in your [survey style](#) or tap *Options* in the *Measure points* screen.

Measuring continuous topo points

1. From the main menu, tap *Measure / Continuous topo*.
2. In the *Method* field, select one of the following:
 - *Fixed time*
 - *Fixed distance*
 - *Time and distance*
 - *Time or distance*
 - *Stop and go*

Note - For a postprocessed survey, you can only use the *Fixed time* continuous method. The *time interval* is set by default to the same value as the *logging interval*.

3. Tap *Options* to configure the quality control, precision, and [tilt settings](#).
4. Enter a value in the *Antenna height* field and make sure that the setting in the *Measured to* field is set appropriately.
5. Enter a value in the *Time interval* field, or the *Stop and go* field and/or the *Distance* field, depending on the method you are using.
6. To generate offsets, set the *Offset* field to *One* or *Two*. The *Fixed time* method does not support offsets.
7. Enter a value in the *Start point name* field (or enter a start point name for the center line when measuring offset points). This increments automatically.
8. If you are measuring an offset line, enter the offset distances and the start point name. To enter a left horizontal offset, enter a negative offset distance or use the *Left* or *Right* pop-up menus.
9. Tap *Measure* to start recording data, and then move along the feature to be surveyed.
If you are using a GNSS receiver with an in-built tilt sensor and *Tilt warnings* has been selected, you will not be able to measure a point until the receiver is within the defined tilt tolerance as indicated by the eBubble.

Note - To change the distance interval, time interval, or offset while measuring points, enter new values in the fields.

10. To stop measuring continuous points, tap *End*.

Tip - To store a position before the predefined conditions have been met, tap *Store*.

Using an Echo sounder to store depths

You can use continuous topo to store depths with measured points.

Configuring the survey style

1. From the Trimble Access menu, tap *Settings / Survey styles / <Style name>*.
2. Tap *Echo sounder*.
3. Select an **instrument** from the *Type* field.
4. Configure the *Controller port*:
 - If you set the *Controller port* to Bluetooth, you must configure the echo sounder **Bluetooth** settings.
 - If you set the *Controller port* to COM1 or COM2, you must configure the port settings.
5. If required, enter the *Latency* and *Draft* and then tap *Accept*.
The latency caters for echo sounders where the depth is received by the controller after the position. General Survey software uses the latency to match and store the depth when it is received with continuous topo points that were saved previously.
6. Tap *Accept* and then tap *Store* to save the changes.

Storing continuous topo points with depths

To store continuous topo points with depths, follow the steps above to [Measure continuous topo points](#), while connected to the echo sounder with a correctly configured survey style.

Notes

- *During the survey, you can disable storing depths with continuous topo points. To do this, tap Options and then clear the Use echo sounder check box. You can also configure Latency and Draft from Options.*
- *The Draft will have an effect on how the antenna height is measured. If the Draft is 0.00 then the antenna height is the distance from the transducer to the antenna. If a Draft is specified, then the antenna height is the distance from the transducer to the antenna, minus the draft.*

When measuring continuous topo points with an echo sounder enabled, a depth is displayed during continuous topo, and also in the map. When a latency has been configured the continuous topo points are initially stored without depths and later updated. The depth that is displayed during continuous topo when a latency has been configured, is an indicator that depths are being received. The depths that are displayed may not be the depths that are stored with the point names that are displayed at the same time.

CAUTION - There are many factors involved in correctly pairing positions with accurate depths. These include sound velocity - which varies with water temperature and salinity, hardware

processing time, and the speed at which the boat is moving. Make sure that you use the appropriate techniques to achieve the required results.

The elevations of continuous topo points stored in General Survey software do not have the depth applied to them. Use *Export custom format* files to generate reports with depths applied.

The following sample reports are available for download from www.trimble.com/Survey/Trimble-Access-IS.aspx:

- [Survey report.xml]
- [Comma Delimited with elevation and depths.xml]
- [Comma Delimited with depth applied.xml]

Note - If a Sonarmite instrument is connected, General Survey software configures it to use the correct output format and mode. For an instrument from another manufacturer, you must manually configure it to use the correct output format.

Fast fix

Tap *Fast fix* to quickly measure and automatically store a construction point. Alternatively, select *Fast fix* from the pop-up menu in the *Point name* field.

Note - In a real-time GNSS survey, *Fast fix* uses the *Rapid point* method. If you need more flexibility, select *Measure* from the pop-up menu in the *Point name* field.

Typically, a construction point is used in *Cogo - compute points* or *Key in - lines and arcs*.

Construction points are stored in the General Survey database with autopoint names that increment from Temp0000. They are classified higher than check points and lower than normal points. For more information, see [Database search rules](#).

To view construction points in a map or list, select them from the *Select filter* list. To view the *Select filter* list, in the :

- 2D map, tap the up arrow to access more softkeys and then tap *Filter*.
- 3D map, tap  and then select *Filter*.

Check point

In a real-time GNSS survey, measure a point twice. Give the second point the same name as the first point. If the duplicate point tolerances are set to zero, the General Survey software warns that the point is a duplicate when you try to store it. Select *Store as check* to store the second point as a check class point. For more information, see [Duplicate point tolerance](#).

Measuring points with a laser rangefinder

To measure laser points as offsets from a known point during a survey, you must first connect the laser rangefinder to the controller and configure the laser rangefinder in your survey style. For more information, see [Configuring a survey style to use a laser rangefinder](#).

1. From the main General Survey screen, tap *Measure*.
2. Tap *Measure laser points*.
3. Enter the point name and a code for the point.
4. In the *Start point* field, do one of the following:
 - Select the point you are measuring the laser point from.
 - Measure a new point using the connected GNSS receiver. To do this:
 - a. Select *Measure* in the *Start point* field.
 - b. Enter the details for the point and then tap *Measure*.
 - c. Tap *Store*.

The software returns to the *Measure laser points* screen and the point you just measured is selected in the *Start point* field.
5. Enter the laser height and the target height.

Note - If you are using the Geo7X laser rangefinder module, make sure you enter the height in the *Laser height* field in the General Survey software, not the laser rangefinder application.
6. Tap *Measure*.
7. Use the laser rangefinder to measure the distance to the target. The details for the measurement appear in the *Measure laser points* screen.
8. Tap *Store*.

Notes

- If you enter a value for magnetic declination in the laser, make sure the *Cogo settings* value is set to zero.
- If the Geo7X laser rangefinder application is set to *Magnetic*, or your laser rangefinder is set to output magnetic azimuths, key in the declination value in *Cogo settings*.
- If the Geo7X laser rangefinder application is set to *True*, the Geo7X obtains the magnetic declination from an internal model and applies that to the azimuth readings. Make sure the *Cogo settings* value is set to zero.
- Allow the laser to settle for a few seconds before you take a measurement with it.
- If the General Survey software receives only a distance measurement from the laser, another screen is displayed with the measured distance in a *Slope distance* field. Enter a vertical angle if the measured distance was not horizontal.
- If you are using a laser without a compass, you must key in a magnetic azimuth before the General Survey software can store the point.

See also:

[Compute point](#)

[Taped distances](#)

Survey – Integrated

Integrated surveys

Using an integrated survey (IS) allows you to connect to both a GNSS receiver and a conventional instrument at the same time.

You can perform an integrated survey using Trimble servo total stations and RTK surveys.

For more information, see:

[Configuring an integrated survey style](#)

[Starting an integrated survey](#)

[Switching between instruments](#)

[Ending an integrated survey](#)

[Using the eBubble in an integrated survey](#)

[Using an IS rover survey rod](#)

Configuring an integrated survey style

An integrated survey style is created by referencing a conventional survey style and an RTK survey style, and then providing additional information specific to the integrated survey.

To configure an integrated survey style:

1. From the Trimble Access menu, tap *Settings / Survey styles* and then tap *New*.
2. Enter the *Style name*, set the *Style type* to *Integrated Surveying* and then tap *Accept*.
3. Select the *Conventional* and *GNSS* styles you want to reference for the integrated style and then tap *Accept*.
4. Enter the *Prism to antenna offset*.
5. Tap *Accept* and then tap *Store* to save the changes.

Note - When the IS rover option is enabled, the only way to change the GNSS antenna height in an integrated survey is to enter the height to the **prism** for the current target. The GNSS antenna height is computed automatically using the Prism to antenna offset configured in the IS style.

Starting an integrated survey

There are a number of ways to start an integrated survey. Use the method that best suits the way you work:

- Start a conventional survey and then start a GNSS survey at a later time.
- Start a GNSS survey and then start a conventional survey at a later time.
- Start an integrated survey. This starts a conventional survey and a GNSS survey at the same time.

To start an integrated survey, first create an [integrated survey style](#), and then select *Measure / <integrated survey style name>*.

To start a single survey, and then start an integrated survey at a later time, begin your first survey as usual and then select *Measure / Integrated surveying*. Only the styles that are configured in the integrated survey style are available in an integrated survey.

Tip - When using an integrated survey you can measure points using GNSS during a Resection and Station Setup Plus.

Switching between instruments

In an integrated survey, the controller is connected to both devices at the same time. This makes switching between instruments very quick.

To switch from one instrument to another, do one of the following:

- Tap the Status line
- Select *Measure / Switch to <survey style type>*
- Tap *Switch to* and then select *Switch to <survey style type>*
- If the Trimble controller has [configurable application/function keys](#), customize one of the keys to *Switch to TS/GNSS* and then press that key.

In an integrated survey, identify the instrument that is currently 'active' by looking at the Status bar or the Status line.

When you use the General Survey software in an integrated survey, there are some areas of functionality within the General Survey software where you cannot switch instruments. For example, if the current screen is Continuous topo.

For more information on how the different features behave, and the way to switch the feature to use the active instrument see the following sections:

Measure topo / Measure points

- If you switch instruments during an integrated survey when you are using Measure topo (conventional), the software automatically switches you to the Measure points (GNSS) screen (and vice versa).
- The **point name** defaults to the next available name.
- The **code** defaults to the last **stored** code.
- Switch instruments before you change the point name and code. If you enter a point name or code before switching instruments, they will not be the default after the switch.

Measure codes

- When you switch instruments, the active instrument is used for the next observation.

Continuous topo

- Only one Continuous topo survey is possible at one time.
- You cannot switch the instrument used in Continuous topo while Continuous topo is running.
- To change the instrument that is being used in Continuous topo, tap *Esc* to **exit** Continuous topo and then restart Continuous topo.
- You can switch instruments if the Continuous topo screen is open but running in the background. If you switch instruments when the Continuous topo screen is running in the background, and you later make the Continuous topo screen the active screen, the General Survey software automatically switches to the instrument with which you started Continuous topo.

Stakeout points, lines, arcs, alignments, and roads

- When you switch instruments, the graphical stakeout display changes.
- If you switch instruments when the Stakeout graphics screen is running in the background, and you later make the Stakeout graphics screen the active screen, the General Survey software automatically switches to the instrument you last used.
- If you switch instruments and a vertical offset to a DTM is specified in the survey style, the vertical offset from the survey style that was last added to the job is used (unless you manually change the vertical offset in the Map options or a Stakeout screen).

Ending an integrated survey

To end an integrated survey, you can end each survey individually, or select *End integrated survey* to end the GNSS survey and the conventional survey at the same time.

Using the eBubble in an integrated survey

If you are using a GNSS receiver with an in-built tilt sensor or an active target, the *eBubble* can be displayed, but for all conventional measurements *Tilt auto-measure* is not supported and no tilt warnings will be issued.

Tips

- Press **CTRL + L** to show or hide the *eBubble*.
- To move the *eBubble*, tap and hold on the *eBubble* then and drag it to a new position.
- Select *Instrument / eBubble options* to configure the *eBubble*. If you are connected to more than one sensor that has an eBubble, tap the appropriate softkey to view the *eBubble options* screen for each sensor.
- The receiver *eBubble* is aligned to the receiver's LED panel. To operate the *eBubble* correctly, the LED panel must be facing you (that is, you must be looking directly at the receiver's LED panel).

IS rover survey rod

When surveying with an integrated survey style you can use an IS rover survey rod.

For more information, see:

[Configuring an IS rover](#)

[Using an IS rover survey rod](#)

Configuring an IS rover

The IS rover survey rod is configured as part of the [integrated survey style](#).

When you configure the IS rover survey rod, enter the *Prism to antenna offset*. The offset is measured from the center of the prism to the position on the GNSS antenna. The position on the GNSS antenna is defined in the *Rover options* form of the GNSS survey style which is referenced by the integrated survey style.

The following table shows the offset distance from the center of the prism to the Trimble R8 antenna:

Prism type	Offset measured to bottom of antenna mount
VX/S Series MT1000	0.034 m
VX/S Series 360°	0.057 m
RMT606	0.033 m
Active Track 360	0.095 m

The following table shows the offset distance from the center of the prism to the Trimble R10 receiver antenna:

Prism type	Offset measured to bottom of quick release
R10 360°	0.028 m
VX/S Series MT1000	0.034 m
Active Track 360	0.095 m

Note - If an incorrect antenna measurement method is set, the incorrect offset is applied to the GNSS antenna heights.

Using an IS rover survey rod

In an integrated survey you must enable *IS rover* and use the target **prism** height to update the GNSS height automatically. When the *IS rover* option is enabled, a change to the conventional target height applies the *Prism to antenna offset* configured in the IS style and automatically updates the GNSS antenna height.

To change the IS rover height:

1. Ensure that the *Prism to antenna* offset is correctly configured and applies to the antenna *Type* and *Measured to* setting configured in the RTK style.

12 Survey – Integrated

2. Tap the target icon in the status bar and select the appropriate target.
3. Enter the *Target height* (the height to the center of the prism).
The updated height is not displayed in the Status bar until the target form is closed.
4. Tap *Antenna* to see the entered target height, style configured prism to antenna offset, and computed antenna height. This step is optional.
5. Tap *Accept*.

Survey – Imaging

Trimble V10 imaging rover

The Trimble V10 imaging rover enables you to capture 360° panoramas. You can capture a panorama and associate it with any measured point, or you can combine capturing panoramas with your usual workflow for measuring points during a conventional survey or a GNSS survey. This requires connecting the following additional equipment to the quick release connector on the V10 camera head:

- For conventional surveys, connect any Trimble prism supported by the Trimble Access software.
- For GNSS surveys, connect any Trimble GNSS receiver that connects to a TSC3 controller or tablet running the Trimble Access software.

For more information, see:

[Equipment setup](#)

[Height measurement methods](#)

[Capturing panoramas when measuring a point in a conventional survey](#)

[Capturing panoramas when measuring a point in a GNSS survey](#)

[HDR imaging](#)

[Attaching a panorama to a point](#)

[Photo station coverage areas](#)

[V10 camera calibration check](#)

[V10 eBubble options](#)

[V10 magnetometer calibration](#)

Equipment setup

This section summarizes how to set up your equipment. For more information on equipment setup, refer to the *Trimble V10 Imaging Rover User Guide*.

Note - You should check the magnetometer calibration and camera calibration regularly.

The power rod is especially designed for use with the V10 imaging rover. The shock absorbing tip will dampen the G-force that the instrument is exposed to each time it is placed in position on the ground.

Attaching the camera head to the power rod or power mount

1. Put the camera head onto the power rod.
2. Turn the power rod until the keying is found.
3. Push the camera head into position.
4. Lock the camera head onto the power rod by screwing the locking collar until it stops.



Connecting a Trimble receiver to the V10

The Trimble R10 GNSS receiver connects directly to the V10 camera head.

To connect any other Trimble [integrated GNSS receiver](#) to the V10 camera head, an adapter between the V10 quick release and the 5/8" thread of the GNSS receiver is needed. If the GNSS radio is used when connected to the V10 camera head, you must also use a specially tuned antenna. For more information, refer to the *Trimble V10 Imaging Rover User Guide*. Once you have fitted the adapter and antenna to the receiver, use the instructions below to connect the receiver to the V10.

Note - Before attaching the prism you must remove the quick release cover. To do this, hold the release cover and at the same time press the quick release button downward. While the quick release button is pressed, pull off the quick release cover.

1. Press the quick release button downward.
2. While the quick release button is pressed, connect the receiver to the camera head.
3. Release the quick release button.

4. Press the receiver down firmly so that the quick release locks in place. To get a water tight seal between the receiver and the camera head, the yellow rubber seal on the top of the camera must be compressed.
5. Make sure the quick release has locked correctly by checking that the quick release button has returned to the top position.

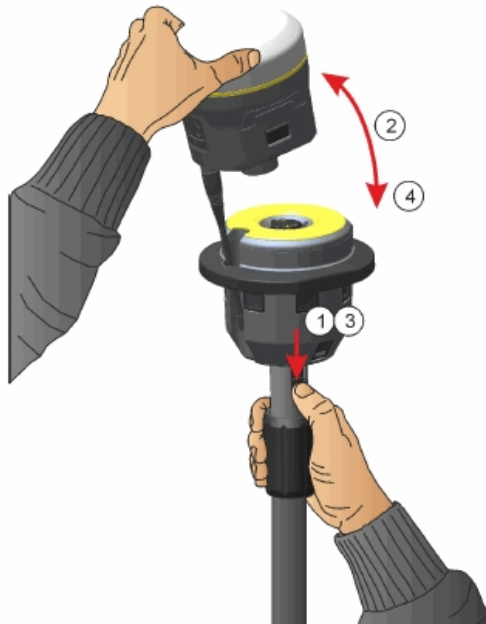

Connecting a Trimble prism to the V10

Note - Before attaching the prism you must remove the quick release cover. To do this, hold the release cover and at the same time press the quick release button downward. While the quick release button is pressed, pull off the quick release cover.

1. Mount the adapter to the prism.
2. Press the quick release button downward.
3. Line up the keying on the prism to the camera head quick release and while pressing the quick release button downward, connect the prism to the camera head. The prism may need to be turned to find the correct position.
4. Release the quick release button.
5. Press the prism down firmly so that the quick release locks in place. To get a water tight seal between the prism and the camera head, the yellow rubber seal on the top of the camera must be compressed.
6. Make sure the quick release has locked correctly by checking that the quick release button has

returned to the top position.

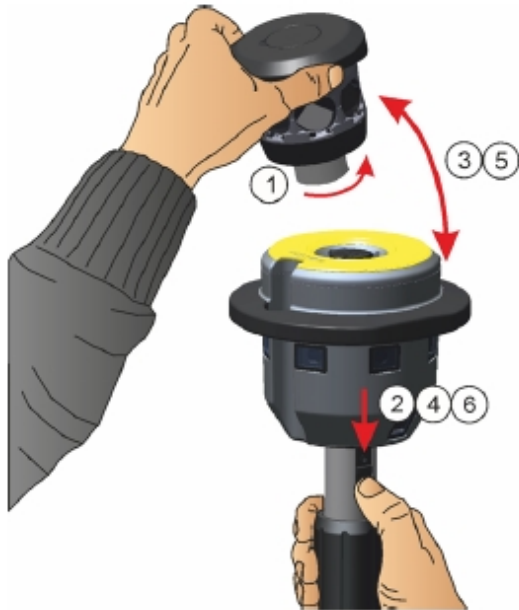

Connecting the V10 to a controller

To attach the V10 to the controller, use the 1.5m USB to mini-USB cable provided by Trimble. Insert the USB connector into the controller and insert the mini-USB connector into the socket on the V10 camera head.

Height measurement methods

The measurement method used when connected to a [V10 imaging rover](#) depends on the other equipment you are using. The measurement method must match the measurement method selected in the software.

The following measurement methods are shown:

- [V10 with Trimble prism mounted on the power rod](#)
- [V10 with Trimble prism fitted to a tripod](#)
- [V10 with Trimble receiver mounted on the power rod](#)
- [V10 with Trimble receiver fitted to a tripod](#)
- [V10 with custom prism and/or custom adapter](#)

V10 with Trimble prism mounted on the power rod

Refer to the following diagram, where (1) is the V10, (2) is the prism, (3) is the bottom of the V10, (4) is the V10 photogrammetry center, (5) is the corrected height to the center of the prism from the

bottom of the pole, and (6) is the height from the bottom of the V10 to the center of the prism. For this value, refer to the table below the diagram.



Prism	Adapter	Bottom of V10 to center of prism (m)
Trimble R10 360, S-Series 360	One-piece	0.151
	Adjustable two-piece	0.160
Trimble AT360, MT1000, S-Series traverse prism	One-piece	0.255
	Adjustable two-piece	0.264

V10 with Trimble prism fitted to a tripod

For high-accuracy measurements, or during calibration check, you must attach the V10 to the V10 power mount and then fit it to a tripod. Measure to the lever of the V10 extension.

Refer to the following diagram where (1) is the V10, (2) is the prism, (3) is the lever of the V10 extension, (4) is the V10 photogrammetry center, (5) is the corrected height to the center of the prism from the ground mark, (6) is the uncorrected height, and (7) is the height from the lever of the V10 extension to the center of the prism. For this value, refer to the table below the diagram.

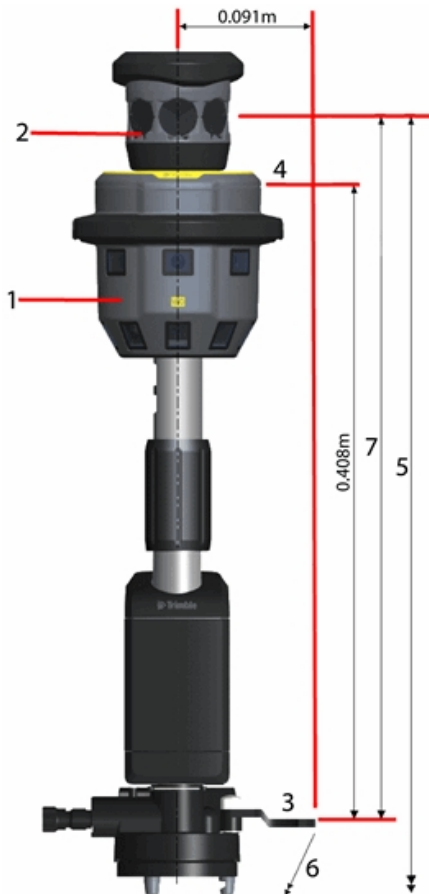

Prism	Adapter	Lever of V10 extension to center of prism (m)
Trimble R10 360, S-Series 360	One-piece	0.451
	Adjustable two-piece	0.460
Trimble AT360, MT1000, S-Series traverse prism	One-piece	0.554
	Adjustable two-piece	0.563

V10 with Trimble receiver mounted on the power rod

Refer to the following diagram, where (1) is the V10, (2) is the receiver, (3) is the bottom of the V10, (4) is the V10 photogrammetry center, (5) is the corrected height to APC from the bottom of the pole, and (6) is the height from the bottom of the V10 to APC. For this value, refer to the table below the diagram.

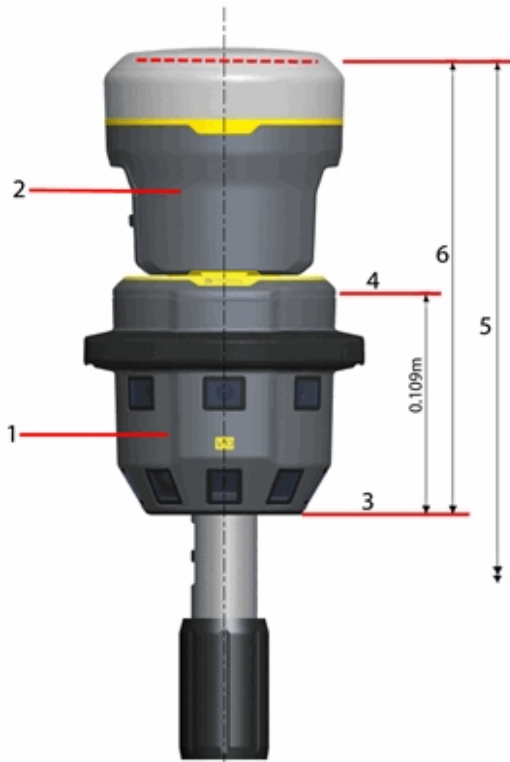

Receiver	Adapter	Bottom of V10 to APC (m)
Trimble R10	None	0.247
Other Trimble integrated GNSS receiver	One-piece	0.185
	Adjustable two-piece	0.194

V10 with Trimble receiver fitted to a tripod

For high-accuracy measurements, or during calibration check, you must attach the V10 to the V10 power mount and then fit it to a tripod. Measure to the lever of the V10 extension.

Refer to the following diagram, where (1) is the V10, (2) is the receiver, (3) is the lever of the V10 extension, (4) is the V10 photogrammetry center, (5) is the corrected height to APC from the ground mark, (6) is the uncorrected height, and (7) is the height from the lever of the V10 extension to APC. For this value, refer to the table below the diagram.

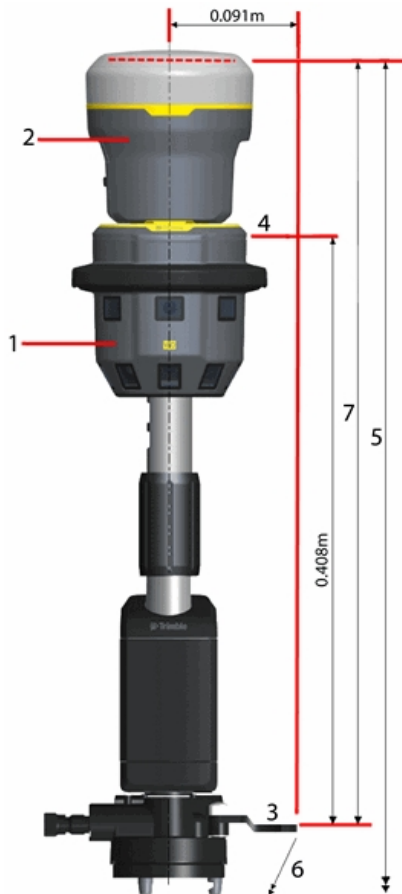

Receiver	Adapter	Lever of V10 extension to APC (m)
Trimble R10	None	0.546
Other Trimble integrated GNSS receiver	One-piece	0.484
	Adjustable two-piece	0.493

V10 with custom prism and/or custom adapter

If you are using a V10 and set the *Quick release adapter* field to *Custom*, you must specify the adaptor base (1) to thread base (2):

Adapter	Adapter base to thread base (m)
Trimble One-piece	0.031
Trimble Adjustable Two-piece	0.022

If you are using a V10 with a custom prism, you must specify the distance from the prism base (3) to the prism center (4).

If you are using a V10 with a custom prism **and** a custom adapter, you must specify distance from the adapter base (1) to the prism center (4).

Refer to the following diagram, where (1) is the adapter base, (2) is the thread base, (3) is the prism base, and (4) is the prism center.

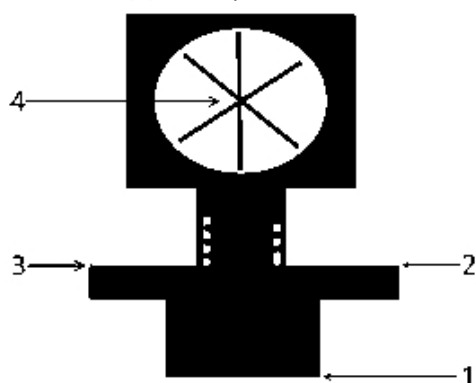

Capturing panoramas when measuring a point in a conventional survey

In a conventional survey, you can capture a panorama when measuring a topo point if the Method is set to Angles and distance or Averaged observations.

1. Connect to the V10. For more information, see [Trimble V10 imaging rover](#).
2. From the main General Survey menu, select *Measure / Measure points*.
3. Enter a value in the *Point name* field, and if required enter a feature code in the *Code* field.
4. Make sure the correct target type is selected. The target type is indicated by the prism icon in the status bar.
5. Select a measurement method and enter a value in the *Target height* field.

Note - Make sure the target height is measured to the bottom of the V10 if you are using the power rod or measured to the lever of the V10 extension if you are using a tripod.
6. Select *Custom adapter* if you have inserted an extension between the adaptor and the prism, and then enter the height for the extension.

7. Tap *Options* to configure the [tilt settings](#) and [HDR settings](#), if you have not already done so.
8. Select the *Panorama* check box.
9. Use the V10 eBubble to ensure the prism is level before you measure the point. Note that when both a V10 and an active target are connected, the information shown in the eBubble is streamed from the active target.

Note - You must use a bipod to keep the power rod vertical and steady during panorama capture.

10. Tap *Start* to start recording data.
11. To store the point, tap *Store*.

The panorama is captured after you tap *Store*.

12. Tap *Store* to store the panorama.

Panorama images are saved to the **<jobname> Files\V10 Panorama Files** folder. The relative path must be maintained when importing data into Trimble Business Center, otherwise the software will not be able to find the panoramas.

Tips

- In the *Panorama* screen, tap the thumbnail to view the larger image.
- Tap *Redo* to recapture the panorama. Tap *Discard* to discard the panorama and delete the point. Tap *Esc* to discard only the panorama.

Note - To capture a panorama for a point that you key in or select from a list, see [Attaching a panorama to a point](#).

Capturing panoramas when measuring a point in a GNSS survey

During a GNSS survey, you can capture a panorama when measuring a *Topo point*, *Observed control point*, *Calibration point* or *Rapid point*.

1. Connect to the V10. For more information, see [Trimble V10 imaging rover](#).
2. From the main General Survey menu, select *Measure / Measure points*.

Note - In a GNSS survey if you are using an Internet connection for your corrections, and your Internet connection is established prior to starting the survey, then you must disconnect the V10 from the controller in order to start the survey. Otherwise the survey will not start and in some instances the connection to the GNSS receiver may be disconnected.

3. Enter a value in the *Point name* field, and if required enter a feature code in the *Code* field.
4. Select a measurement method.
5. Enter a value in the *Antenna height* field and make sure that the setting in the *Measured to* field is set to *Bottom of V10* if you are using the power rod or set to *Lever of V10 extension* if you are using a tripod.
6. Select *Custom adapter* if you have inserted an extension between the adapter and the receiver, and then enter the height for the extension.

7. Tap *Options* to configure the quality control, precision, [tilt settings](#), and [HDR settings](#), if you have not already done so.
8. Select the *Panorama* check box.
9. Use the eBubble to ensure the antenna is level before you measure the point. Note that when both a V10 and an Trimble R10 receiver are connected, the information shown in the eBubble is streamed from the Trimble R10 receiver.

Note - You must use a tripod to keep the power rod vertical and steady during panorama capture.

10. When the antenna is vertical and stationary, tap *Start* to start recording data. The static icon appears in the status bar.
11. When the preset occupation time, precisions, and tilt tolerance have been reached, tap *Store*. The panorama is captured after you tap *Store*.
12. Tap *Store* to store the panorama.

Panorama images are saved to the **<jobname> Files\V10 Panorama Files** folder. The relative path must be maintained when importing data into Trimble Business Center, otherwise the software will not be able to find the panoramas.

Tips

- In the *Panorama* screen, tap the thumbnail to view the larger image.
- Tap *Redo* to recapture the panorama. Tap *Discard* to discard the panorama and delete the point. Tap *Esc* to discard only the panorama.

Note - To capture a panorama for a point that you key in or select from a list, see [Attaching a panorama to a point](#).

HDR imaging

The V10 imaging rover enables you to capture high dynamic range (HDR) images.

With HDR turned on, the V10 captures three images rather than one image, each with different exposure settings. Immediately after image capture, the V10 processes the images to produce a single composite image, which has better tonal range and can therefore show more detail than any of the individual images.

Enabling HDR

1. Open the measurement method options screen. To do this, do one of the following:
 - In the *Measure point* screen, tap *Options*.
 - In the *V10 Panorama* screen, tap *Options*.
 - When configuring the survey style, select *Measurement method options*.
2. Select the *HDR* check box.

HDR appears next to the V10 icon in the status bar  HDR to indicate that HDR is turned on.

Notes

- The V10 imaging rover must have firmware version E1.0.xx or later.

Attaching a panorama to a point

When the controller is connected to a [V10 imaging rover](#), you can capture a panorama for a point that you key in or select from a list.

Note - You do not need to have started a survey or be connected to any other sensor to do this.

1. Tap *Instrument / V10 Panorama*.
2. Enter the point name or select the point from a list.
If you enter a point name that does not exist, then *North*, *East*, and *Elevation* fields allow you to key in the coordinates.
To capture a panorama for a point that has no coordinates, leave the coordinate fields in this screen empty.
3. Enter the *Instrument height*, measured to the bottom of the V10 if you are using the power rod or measured to the lever of the V10 extension if you are using a tripod. To set this, tap the arrow beside the *Height* field and then select the appropriate method.
4. Select *Custom adapter* if you have inserted an extension between the adapter and the prism or receiver, and then enter the height for the extension.

Note - You must use a bipod to keep the power rod vertical and steady during panorama capture.

5. Use the eBubble to check the tilt of the pole. The eBubble in the V10 Panorama screen always shows tilt information for the V10 imaging rover, even if another tilt sensor is connected. When the bubble is within the tilt tolerance, tap *Start* to capture the panorama.
6. In the *Panorama* screen, tap the thumbnail to view the larger image. Tap *Store* to store the panorama. Tap *Redo* to recapture the panorama. Tap *Esc* to discard the panorama.

Panorama images are saved to the **<jobname> Files\V10 Panorama Files** folder. The relative path must be maintained when importing data into Trimble Business Center, otherwise the software will not be able to find the panoramas.

V10 photo station coverage areas

If you have a job with photo stations attached to a point with coordinates then a coverage area for the photo station is displayed in the map. The photo station coverage area shown depends on whether you are in the [map](#) or the [3D map](#). The coverage area indicates the area captured for the photo station, with the lines shown at ground level. The software uses the instrument height for the V10 panorama and assumes the ground is level.

Note - The photo station coverage area is oriented to match the orientation of the camera head. For the photo station coverage area to be oriented correctly, you must set the magnetic declination for the job. To do this, from the main General Survey menu tap *Jobs / Properties of job / Cogo settings*.

To control whether photo station coverage areas are displayed, toggle them on or off using the *Select filter* list. To view the *Select filter* list, in the :

- 2D map, tap the up arrow to access more softkeys and then tap *Filter*.
- 3D map, tap  and then select *Filter*.

Photo station coverage areas in the map

The downward facing cameras capture the area between bounding lines 1 and 2. The outward facing cameras capture the area from bounding line 3 outward.

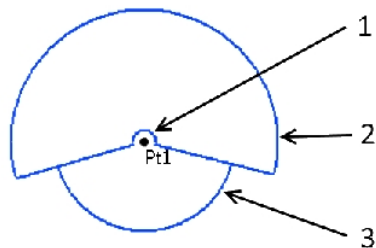
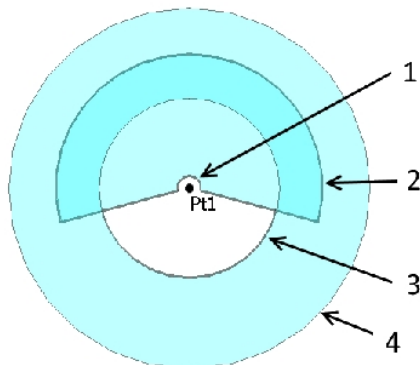

Photo station coverage areas in the 3D map

The downward facing cameras capture the area between bounding lines 1 and 2. The outward facing cameras capture the area from bounding line 3 outward. Line 4 is an arbitrary outer limit.



V10 camera calibration check

To check the camera calibration of the [V10 imaging rover](#), perform the camera field calibration check and then process the job containing the camera calibration data in Trimble Business Center.

Calibration check images are saved to the <jobname> Files\V10 Panorama Files folder. The relative path must be maintained when importing data into Trimble Business Center, otherwise the software will not be able to find the images.

Note - The camera calibration check does not calibrate or "correct" the camera. It is a process used to collect images to evaluate if the calibration of the cameras is still within specifications.

1. Select *V10 settings*.
2. Tap *Check*.
3. Enter the distance from the V10 to the wall where you will mount the wall target, ensuring it is within prescribed limits.
4. Enter the height of the instrument, ensuring it is within prescribed limits.
5. Tap *Next*.
6. Position the targets as shown in the software, within the prescribed limits.
7. Enter the height to the center of the wall target.
8. Enter the distance from the wall to the center of the floor target.
9. Tap *Next*.
10. Rotate the V10 until the red line runs through the center of the target. Tap *Next* to save the image pair. Repeat this step until you have captured all image pairs.
11. Process the job in Trimble Business Center.

For more information, refer to the *Trimble V10 Imaging Rover User Guide*.

V10 eBubble options

The V10 has inbuilt tilt sensors so an eBubble (electronic bubble) is available.

Note - If another tilt sensor is connected as well as the V10, then the V10 eBubble appears only in the V10 Panorama screen. Elsewhere in the Trimble Access software, the eBubble shows information from the other tilt sensor. For more information, see [Receiver eBubble options](#) and [AT360 eBubble options](#).

To configure the V10 eBubble, tap *Instrument / eBubble options* from the main menu. You can configure the following settings:

Option	Description
eBubble sensitivity	The bubble moves 2mm for the specified sensitivity angle. To decrease sensitivity select a large angle.
Tilt tolerance	Defines the maximum radius that the V10 can tilt and be considered in tolerance. The allowable range is 0.001m to 1.000m. The tilt distance shown is calculated using the current antenna height.
eBubble response	Controls the eBubble's responsiveness to movement.

Tip - You can also access the *V10 eBubble options* screen by doing one of the following:

- Tap the Settings icon in the top left corner of the *eBubble* window.
- Tap the *V10* softkey from the *eBubble options* screen for a different sensor. If you have more than one tilt sensor connected, changing the *eBubble* settings for one sensor changes the *eBubble* settings for all connected tilt sensors.

eBubble display

To display the *eBubble*, tap the *eBubble* softkey.

Bubble color	Meaning
Green	You are within the defined tilt tolerance.
Red	You are outside the defined tilt tolerance.

Tips

- To move the *eBubble* window to a new position on the screen, tap and hold on the *eBubble* and drag to a new position.
- Press **CTRL + L** to show or hide the *eBubble* from any screen.

V10 magnetometer calibration

The magnetometer calculates the direction that the *V10 imaging rover* is facing so that the panoramas can be oriented correctly. Trimble recommends calibrating the magnetometer whenever the configuration of equipment on the power rod changes, for example, if you add or remove a Trimble receiver or prism.

WARNING - The performance of the magnetometer is affected by nearby metal objects (for example, vehicles or heavy machinery) or objects that generate magnetic fields (for example, high voltage overhead or underground power lines). Always calibrate the magnetometer away from sources of magnetic disturbance. In practice this usually means outdoors.

Note - *Calibrating the magnetometer near sources of magnetic disturbance does not "correct" for the interference caused by these objects.*

Calibrating the magnetometer

1. In the *Instrument* screen, tap *eBubble options* and then tap *Calib*.
2. To perform the magnetometer calibration, tap *Calibrate*.
3. Tap *Start* and then rotate the *V10* as shown on-screen, until calibration is complete.

Notes

- *If the V10 suffers severe abuse such as a pole drop, you should recalibrate the magnetometer.*
- *If you tap Cancel before the calibration is complete, the existing magnetometer calibration is used.*

13 Survey – Imaging

- *The runtime displayed for the V10 in the Calibration screen is the amount of time the V10 has been running since the last calibration.*
- *The details of the calibration are stored in the job and can be reviewed from Jobs / Review job.*

Survey – Stakeout

Stakeout – Overview

In a real-time GNSS survey or a conventional survey, you can stake out points, lines, arcs, polylines, alignments, roads, and DTMs.

To stake out an item:

- Define the item to be staked out.
- From the map, or from *Stakeout*, select the item to be staked out.
- Navigate to the point, or direct the person holding the rod to the point.
- Mark the point.
- Measure the point (optional).

You can define the item to be staked out:

- in the *Key in* menu
- with a [linked CSV or job file](#)
- from lines and arcs uploaded with the job file
- from an [active map](#) file
- from an alignment (.rxl) or road (.rxl, crd, .inp, .mos, or .xml)

To stake out a line between two points without keying the line into the job database, you can select two points from the map, tap and hold in the map to access the pop-up menu and then select *Stake out line*.

To use GNSS to stake out lines, arcs, Digital Terrain Models, and alignments, you must define a projection and datum transformation.

WARNING - Do not change the coordinate system or calibration after you have staked out points.

For more information, see:

[Arcs](#)

[Lines](#)

[Points](#)

[Alignments \(polylines\)](#)

[DTMs](#)

[Stakeout - Display mode](#)

Stakeout - Options

Using the graphical display

Configuring the stakeout display mode

The display varies depending on whether you are performing a [Conventional](#) or [GNSS](#) survey.

Conventional surveys

For a conventional survey the [Stakeout graphical display](#) screen displays directions using the conventional instrument as a reference point.

For a conventional survey, you can configure the *Stakeout directions* and the *Display mode* of the [Stakeout graphical display](#).

Offset & Stakeout directions allows you to configure the stakeout directions to be from an instrument perspective, target perspective, or automatic. *Automatic* configuration sets the stakeout directions automatically, based on whether you have a servo connection or a robotic connection to the instrument:

Display mode allows you to configure the graphical navigation display.

When the *Display mode* is set to *Direction and distance*, the navigation screen displays:

- A large arrow pointing in the direction you have to move. When you are close to the point, the arrow changes to the in/out and left/right directions, relative to the instrument.

When the *Display mode* is set to *In/out and left/right*, the navigation screen displays:

- In/out and left/right directions, with the conventional instrument as a reference point.

To configure the display:

1. From the Trimble Access menu, tap *Settings / Survey styles / <Style name> / Instrument*.
2. Set the *Offset & Stakeout directions*:
 - Automatic - navigation directions are from *Instrument perspective* (during a servo connection), or *Target perspective* (during a robotic survey).
 - Instrument perspective (standing behind the instrument) - in/out and left/right navigation directions given from an instrument perspective, looking from the instrument towards the target.
 - Target perspective (standing at the target) - in/out and left/right navigation directions given from a target perspective, looking from the target towards the instrument.
3. Tap *Accept*, and then select *Stakeout*.
4. Set the *Display mode*:
 - Direction and distance - navigate using the large arrow, similar to GNSS stakeout. When you are close to the point, the display automatically changes to the in/out and left/right display.
 - In/out and left/right - navigate using in/out and left/right directions, with the instrument as a reference point.

5. Choose a setting in the *Deltas (points)* and *Deltas (other)* fields. The two deltas fields allow you to configure one deltas default for point stakeout, and the other deltas default for arc, line, alignment and road stakeout.
 - Distances - navigate to a point using distances only
 - Delta grid - navigate to a point using delta grid values
 - Station and offset - navigate to a point using station and offset when staking a line or arc.

When staking to the line or arc the station and offset view displays the Station, H.offset, V.Dist and the Grade.

When staking to the Station on the line / arc or the Station/offset from line / arc the view displays the Station, H.offset, V.dist, delta Station and delta H.offset.
6. Use the *Distance tolerance* field to specify the allowable error in distance. If the target is within this distance from the point, the graphical stakeout display indicates that the distance(s) is correct.
7. Use the *Angle tolerance* field to specify the allowable error in angle. If the conventional instrument is turned away from the point by less than this angle, the graphical stakeout display indicates that the angle is correct.
8. If a *DTM* file has been transferred into the General Survey software, you can select the *Display cut/fill to DTM* check box, and the graphical display screen will display the cut or fill relative to that DTM. Use the *DTM* field to specify the name of the DTM to be used. If necessary, specify a vertical offset to raise or lower the DTM. Tap  and select whether the offset is to be applied vertical or perpendicular to the DTM.

Note - All DTM files from all folders are listed.

Alternatively, tap *Options* from the *Stakeout* screen to configure the settings for the current survey.

GNSS surveys

For a real-time GNSS surveys, you can set the mode of the *Stakeout graphical display* so that the point stays fixed in the center of the screen, or so that your position stays fixed in the center of the screen.

To configure the display:

1. From the Trimble Access menu, tap *Settings / Survey styles / <Style name> / Stakeout*.
2. In the *Display mode*, select either *Target centered*, or *Surveyor centered*.
3. Choose a setting in the *Deltas* field. The options are:
 - Azimuth and distance - navigate to a point using azimuth and distance
 - Delta grid - navigate to a point using delta grid values
 - Station and offset - navigate to a point using station and offset
 - Forward / Backward - navigate to a point using distances with "Go forward/back" and "Go left/right" commands

When staking To the line or arc the station and offset view displays the Station, H.offset, V.Dist and the Grade.

When staking to the Station on the line or arc, or the Station/offset from line or arc the view displays the Station, H.offset, V.Distance, delta Station and delta H.offset.

4. Choose a setting in the *Display orientation* field. The options are:
 - Direction of travel - the screen will orientate so that the top of the screen points in the direction of travel.
 - North / Sun - the small orientation arrow shows the location of North or the sun. The screen will orientate so that the top of the screen points toward North or the sun. When using the display, tap the *North/Sun* softkey to toggle the orientation between north and the sun.
 - Reference azimuth:
 - For a point the screen will orientate to the azimuth specified when the *Stake* option is set to *Relative to azimuth*.
 - For a line the screen will orientate to the azimuth of the line.

Notes

- If, when staking a point, the *Display orientation* is set to *Reference azimuth* and the *Stake* option is not set to *Relative to azimuth* the display orientation behaviour will default to *Direction of travel*.
 - When using the *controller's* internal compass, the compass is ignored if the *Display orientation* is set to *North* or *Reference azimuth*.
5. If a *DTM* file has been transferred into the General Survey software, you can select the *Display cut/fill to DTM* check box, and the graphical display screen will display the cut or fill relative to that *DTM*. Use the *DTM* field to specify the name of the *DTM* to be used. If necessary, specify a vertical offset to raise or lower the *DTM*. Tap  and select whether the offset is to be applied vertical or perpendicular to the *DTM*.

Note - All *DTM* files from all folders are listed.

Alternatively, tap *Options* from the *Stakeout* screen to configure the settings for the current survey.

Using the graphical display during stakeout

The graphical display in *Stakeout* helps you to navigate to a point. The display varies depending on whether you are performing a *Conventional* or *GNSS* survey.

Tip - Depending on the *controller* you are using, you may be able to use the internal compass to aid navigation. See *Compass* for further details.

Conventional

To use the graphical display in a conventional survey:

If you are using the *Direction and distance* mode:

1. Hold the display screen in front of you as you walk forwards in the direction that the arrow is pointing. The arrow points in the direction of the point.

- When you get to within 3 meters (10 feet) of the point, the arrow disappears, and the in/out and left/right directions appear, with the instrument as a reference point. Follow the instructions below to navigate in this mode.

Note - When navigating to the position, a grid is displayed as you near the target and when the large navigation arrow disappears. The grid changes scale as you move closer to the target.

If you are using the *In/out and left/right* mode:

- The first display shows which way the instrument should be turned, the angle that the instrument should display and the distance from the last point staked to the point currently being staked.
- Turn the instrument (two outline arrows will appear when it is on line), and direct the rod person on line.

If you are using a servo instrument, and the *Servo auto turn* field in the survey style is set to *HA & VA*, or *HA only* the instrument automatically turns to the point.

If you are working robotically, or when the *Servo auto turn* field in the survey style is set to *Off*, the instrument does not turn automatically. To turn the instrument to the angle indicated on the screen, tap *Turn*.

- If the instrument is not in *TRK* mode, tap *Measure* to take a distance measurement.
- The display shows how far the person holding the rod should move towards or away from the instrument.
- Direct the person holding the rod, and take another distance measurement.
- Repeat steps 2 - 5 until the point has been located (when four outline arrows are displayed), then mark the point.
- If a measurement to the target is within the angular and distance tolerances, tap *Store* at any time to accept the current measurement.

If the instrument is in *TRK* mode and you require a higher precision distance measurement, tap *Measure* to take an *STD* measurement and then tap *Store* to accept that measurement.

To discard the *STD* measurement and return the instrument to *TRK* mode, tap *Esc*.

If you are operating a robotic instrument remotely from the target:

- the instrument automatically tracks the prism as it moves
- the instrument continuously updates the graphical display
- the graphical display is reversed and the arrows are shown from the target (prism) to the instrument

GNSS

When you use the graphical display in a GNSS survey to navigate to a point, the screen first shows a large navigation arrow when you are some distance away from the point and then automatically changes to a bull's-eye target as you move in closer.

Note - When the *Display orientation* is set to *Direction of travel*:

- The arrow assumes that you are moving forward at all times.
- The bull's eye target does not assume that you are moving forward.

Tap the *North/Sun* softkey to change the reference point used by the small orientation arrow.

To use the graphical display in a GNSS survey:

1. Hold the display screen in front of you as you walk forwards in the direction that the arrow is pointing. The arrow points in the direction of the point that you intend to measure.
2. When you get to within 10 feet (3 meters) of the point, the arrow disappears and a bull's-eye target appears.

When the bull's-eye target is displayed, do not change your orientation. Keep facing in the same direction and only move forwards, backwards, left or right.

Note - *When staking a Point, Line, Arc or Alignment a grid is displayed as you near the target and when the large navigation arrow disappears. The grid changes scale as you move closer to the target.*

3. Continue moving forwards until the cross, representing your current position, covers the bull's-eye target, representing the point. Mark the point.

Stakeout options

Configure the stakeout settings when you create or edit a survey style.

Select *Stakeout* and set the *As-staked point details*, and *Stakeout display mode*.

If you do not want the total station EDM set to *TRK* mode when you enter stakeout, clear the *Use TRK for stakeout* check box.

Alternatively, tap *Options* from the *Stakeout* screen to configure the settings for the current survey.

If you do not want the point removed from the stake out point list after it has been staked, clear the *Remove staked point from list* check box.

Tap *Options* from the *Stakeout* screen to enable/disable the internal *compass*. See *Controllers* to check if your controller has an internal compass.

In a GNSS survey, select the *Auto measure* option to automatically start measuring when the *Measure* key is tapped.

As-staked point details

Configure the *As-staked point* details either in the *Stakeout* option, when you create or edit a survey style, or by tapping *Options* in the *Stakeout* screen.

You can configure the *View before storage*, *Horizontal tolerance*, *Staked deltas format*, *As-staked name*, *As-staked code*, and *Store grid deltas*.

View before storage and horizontal tolerance

If you want to see the differences between the design point and the as-staked point before you store the point, select the *View before storage* check box and then choose one of these options:

- To see the differences every time, set the Horizontal tolerance to 0.000 m.
- To see the differences only if the tolerance is exceeded, set the Horizontal tolerance to a suitable value.

Note - The Stake delta values are reported as differences **from** the measured/as-staked point **to** the design point.

User definable stakeout reports (staked deltas format)

The General Survey software supports user-definable stakeout reports, which enable you to configure the display of staked information on the *Confirm staked deltas* screen that appears when you enable *View before storage*.

User definable stakeout reports can offer the following benefits:

- important information can be displayed first
- the data can be ordered to suit the user's requirements
- information that is not required can be removed
- additional data can be computed for display, for example by applying construction offsets to reported values
- the point design elevation can be edited after the stake out measurement is completed
- up to 10 extra design elevations with individual vertical offset values can be defined and edited, with the cut/fill to each extra design elevation being reported

Formatting of the staked deltas screen also supports the following settings:

- the size of the font for prompts
- the size of the font for reported values
- the color of the font for prompts
- the color of the font for reported values
- widescreen on or off

The content and format of the stakeout reports is controlled by XSLT style sheets. Translated default XSLT Stakeout Style Sheet (*.sss) files are included with the language files, and accessed by the General Survey software from the language folders. You can create new formats in the office and then copy them to the [System files] folder on the controller.

From the *Staked deltas format* field, select an appropriate display format.

The following list shows the translated stakeout reports that are supplied with the language files, and the support offered by those reports:

- Point - Stake markup
Provides a simplified stakeout display that presents the vertical distance (cut/fill) to the design point. The vertical distance to a DTM will also be displayed if applicable.
- Point - Stake multiple elevs

Provides a stakeout display that allows you to edit the point design elevation (the cut/fill value will be updated) and entry of up to two extra design elevations with associated vertical offsets and updated cut/fill values.

- Line - Stake markup

Provides a simplified stakeout display that presents the vertical distance (cut/fill) to the design position. The appropriate station and offset values are reported, based on the selected line stakeout method.

- Arc - Stake markup

Provides a simplified stakeout display that presents the vertical distance (cut/fill) to the design position. The appropriate station and offset values are reported, based on the selected arc stakeout method.

- DTM - Stake markup

Provides a simplified stakeout display that presents the vertical distance (cut/fill) to the DTM being staked.

If the Roads application is installed, the following additional translated stakeout reports are available:

- Road - Catch + offsets

Provides details of all the standard road staked deltas plus a list of the horizontal and vertical distances to each of the cross-section positions from the staked offset position. The reported horizontal and vertical distances include the applied horizontal and vertical construction offsets.

- Road - Stake markup

Provides a simplified stakeout display that presents the vertical distance (cut/fill) to the road design position. Appropriate station and offset values and cross-section details (in the case of catch point staking) are reported, based on the road stakeout method.

- Road - XS details

Provides all the standard road staked deltas details as well as a list of the cross-section elements (left and right) that define the design cross-section at the selected station.

If the Pipelines application is installed, the following additional translated stakeout reports are available:

- Pipelines - Alignment stakeout

Provides details of all the standard alignment staked deltas plus the ahead and behind station values are now reported for positions measured in the internal and external angles of non-tangential intersection points in the alignment.

Select this *Staked delta format* when staking a pipeline alignment.

- Pipelines - Points stakeout

Provides details of all the standard point staked deltas plus the ahead and behind station values are now reported for positions measured in the internal and external angles of non-tangential intersection points in the alignment.

Select this *Staked delta format* when staking points.

Refer to the diagram where:

- 1 Staked point
- 2 Ahead station
- 3 Ahead offset
- 4 Back station
- 5 Back offset

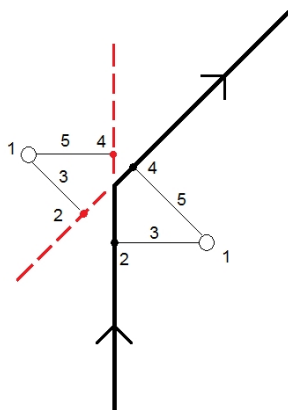

Tip - When you use multiple Stakeout Style Sheet files, Trimble recommends that you set the Staked deltas format. From the Trimble Access menu, tap *Settings / Survey styles / <Style name> / Stakeout*, to configure unique formats for Points, Lines, Arcs, DTMs, and Roads. You can also select the format within *Options* during stakeout.

Note - The development of the XSLT style sheets is an advanced procedure recommended for users with programming experience. For more information, please refer to the stylesheets available at www.trimble.com/Survey/Trimble-Access-IS.aspx.

As-staked name and as-staked code

You can set the **name** of the As-staked point to be one of the following:

- the next *Auto point name*
- the *Design point name* (not available for roads)

You can also set the **code** of the As-staked point to be one of the following:

- *Design name*
- *Design name (with prefix)*
- *Design name (with suffix)*
- the next *Auto point name*
- *Design code*
- *Last code used*
- *Design station and offset*

For the design name options that have a prefix or suffix, complete the *Prefix/Suffix* field as required.

Note – The design name options are available only when staking points.

The **Description** defaults as follows:

- When staking a point, line or arc with descriptions, the description of the as-staked point will default to the description of the design entity unless the *As-staked* code is set to *Last code used* in which case the last used description is used.

- When staking a road using the Roads application, the description will always be the last used independent of the *As-staked code* setting.

Store grid deltas

Set the *Store grid deltas* check box. Do one of the following:

- Select the check box to display and store the delta northing, delta easting, and delta elevation during stakeout.
- Clear the check box to display and store the deltas as a horizontal distance, vertical distance, and azimuth.

Note - If you use a user definable stakeout report, the *Store grid deltas* option is not used, unless it is referenced in your report.

Staking out points

There are many ways to stake a point. Select the method that suits you best:

- From the [Map - single point](#)
- From the [Map - using a list](#)
- From [Stakeout / Points- single point](#)
- From [Stakeout / Points- using a list](#)
- From [Stakeout / Points- using a CSV/TXT file](#)

For more information, see:

[GNSS stake methods](#)

[Editing the design elevation](#)

[Offsetting a point](#)

Tip – When using a GNSS receiver with an in-built tilt sensor, you can:

- Tap [eBubble](#) to display an electronic bubble
- Configure the survey style to prompt a warning when the pole is outside a specified [Tilt tolerance](#)
- Tap [Options](#) to configure the quality control, precision, and [tilt settings](#).

Staking a single point from the Map

1. From the map, do one of the following:
 - Select the point to be staked out and then tap [Stakeout](#).
 - Double-tap the point to be staked.

2. Do one of the following:
 - In a GNSS survey:
 - If the antenna height is null, select the [Stake method](#), enter the *Antenna height*, and set the *Measured to* field appropriately and then tap *Start*.
 - If the antenna height was configured in the survey style, or recently entered, you are not prompted to enter the antenna height again.
To change the antenna height, tap the antenna icon in the status bar and then enter the new value in the screen that appears. Tap *Accept*.
 - In a conventional survey:
 - To change the target height, tap the target icon in the status bar, tap the antenna height field and then enter the new value in the screen that appears. Tap *Accept*.
3. Use the [graphical display](#) to navigate to the point.
If required, [edit the design elevation](#).
4. When the point is within tolerance, measure the point.
When the point has been stored, you are returned to the map. The selection of the point that was just staked has been removed.
5. Select another point to stake and then repeat the process.

Staking a group of points from the Map

1. From the map, select the point(s) to be staked out. Tap *Stakeout*.
If you have selected more than one point from the map for staking out, the *Stake out points* screen appears. Go to the next step. If you have selected one point from the map, go to step 4.
2. The *Stake out points* screen lists all points selected for stakeout. To add more points to the list, do one of the following:
 - Tap *Map* and then select the required points from the map. Tap *Stakeout* to return to the *Stake out points* screen.
 - Tap *Add* and then add points using one of the [methods listed](#) to add more points to the list.
3. To select a point for stake out, do one of the following:
 - Tap the point name.
 - Use the controller arrow keys to highlight the point and then tap *Stakeout*.
4. Do one of the following:
 - In a GNSS survey:
 - If the antenna height is null, select the [Stake method](#), enter the *Antenna height*, and set the *Measured to* field appropriately and then tap *Start*.
 - If the antenna height was configured in the survey style, or recently entered, you are not prompted to enter the antenna height again.
To change the antenna height, tap the antenna icon in the status bar and then enter the new value in the screen that appears. Tap *Accept*.

- In a conventional survey:
 - To change the target height, tap the target icon in the status bar, tap the antenna height field and then enter the new value in the screen that appears. Tap *Accept*.
- 5. Use the [graphical display](#) to navigate to the point.
If required, [edit the design elevation](#).
- 6. When the point is within tolerance measure the point.
When the point has been stored, the point is removed from the stake out list and you are returned to the stake out point list.
- 7. Select the next point and then repeat the process.

Staking a single point from the Stakeout menu

1. From the main menu, select *Stakeout / Points*.
2. Make sure that you are in the stake a single point mode:
 - If a *Point name* field is displayed, stake out point is in the stake a single point mode.
 - If a stake out point list is displayed, stake out point is in the stake from a list mode. Tap > *Point* to change to the stake a single point mode.
3. Enter the name of the point to stake, or tap the pop-up arrow and then select a point using one of the following methods:

Method	Description
List	Select from a list of all points in the current job and linked files.
Wildcard search	Select from a filtered list of all points in the current job and linked files.
Key in	Key in the coordinates of the point to stake.

Tip - Tap *Closest* to automatically populate the *Point name* field with the name of the closest point. *Closest* searches the current job and all linked files to find the closest point that is **not** an as-staked point or a design point for the as-staked points.

4. Enter the *Point increment* and then tap *Stakeout*. Do one of the following:
 - To return to the stake out point screen after staking a point, enter an increment of 0 or ?.
 - To stay in the graphical stake out display and automatically increment to the next point, enter a valid increment value.

If a point does not exist using the increment specified, tap *Cancel* to return to this form after staking a point. Alternatively, tap the *Search* button to find the next available point.

You can use a decimal point increment, for example 0.5. You can also increment the numeric component of a point name that ends in alpha characters, for example, you can increment 1000a by 1 to 1001a. To do this, tap the advanced pop-up arrow on the point increment field and then clear the *Apply to numeric only* setting.

5. Do one of the following:

- In a GNSS survey:
 - If the antenna height is null, select the *Stake method*, enter the *Antenna height*, and set the *Measured to* field appropriately and then tap *Start*.
 - If the antenna height was configured in the survey style, or recently entered, you are not prompted to enter the antenna height again.
 - o change the antenna height, tap the antenna icon in the status bar and then enter the new value in the screen that appears. Tap *Accept*.
 - In a conventional survey:
 - To change the target height, tap the target icon in the status bar, tap the antenna height field and then enter the new value in the screen that appears. Tap *Accept*.
6. Use the *graphical display* to navigate to the point.
If required, *edit the design elevation*.
 7. When the point is within tolerance measure the point.
 8. When the point has been stored, the increment value is used to determine the next point to stake:
 - If the next point using the increment value exists, you remain in the stake out graphics screen with the navigation details updated for the next point.
 - If the next point does not exist, tap *Cancel* to return to the stake out point screen where you can enter the name of the next point to stake. Alternatively, tap the *Search* button to find the next available point.

Tip - When using stake a single point mode, you can still use a stake point list to ensure that you stake all required points. To do this, build the stake list, make sure that *Remove staked point from list* is enabled, and stake points using the stake a single point mode. As points are staked they will be removed from the stake list. Tap > *List* as required to check which points still need to be staked.

Staking a group of points from the Stakeout menu

1. From the main menu, select *Stakeout / Points*.
2. Make sure that you are in the stake out list mode:
 - If a stake out point list is displayed, stake out point is in the stake from a list mode.
 - If a *Point name* field is displayed, stake out point is in the stake a single point mode. Tap > *List* to change to the stake from a list mode.
3. The *Stake out points* screen lists all points selected for stake out. The list may already contain points that were added to the list previously but not staked out.
Tap *Add* and add points using one of the *methods listed* to add more points to the list.
4. To select a point for stake out, do one of the following:
 - Tap the point name.
 - Use the controller arrow keys to highlight the point and then tap *Stakeout*.
5. Do one of the following:

- In a GNSS survey:
 - If the antenna height is null, select the *Stake method*, enter the *Antenna height*, and set the *Measured to* field appropriately and then tap *Start*.
 - If the antenna height was configured in the survey style, or recently entered, you are not prompted to enter the antenna height again.
To change the antenna height, tap the antenna icon in the status bar and then enter the new value in the screen that appears. Tap *Accept*.
 - In a conventional survey:
 - To change the target height, tap the target icon in the status bar, tap the antenna height field and then enter the new value in the screen that appears. Tap *Accept*.
6. Use the *graphical display* to navigate to the point.
If required, *edit the design elevation*.
 7. When the point is within tolerance measure the point.
When the point has been stored, the point is removed from the stake out list and you are returned to the stake out point list.
 8. Select the next point and then repeat the process.

Staking out points from a CSV/TXT file or another job

There are many ways to stake out points in a linked file; from linked points displayed in the *map*, or using various methods to *build a stake out list*.

This section describes how to build a stake out list from a CSV/TXT or Job file that does not need to be linked:

1. From the main menu, select *Stakeout / Points*.
2. Make sure that you are in the stake out list mode:
 - If a stake out point list is displayed, stake out point is in the stake from a list mode.
 - If a *Point name* field is displayed, stake out point is in the stake a single point mode. Tap *> List* to change to the stake from a list mode.
3. Tap add and choose *Select from file*.
4. Choose the file from which to select points to add to the stake out list. Do one of the following:
 - Tap the file.
 - Use the controller arrow keys to highlight the file and then tap *Accept*.
5. If *Advanced Geodetics* is enabled, and you select a CSV or TXT file, you must specify if the points in the linked file are Grid points or Grid (local) points.
 - Select *Grid points* if the points in the CSV/TXT file are grid points.
 - Select *Grid (local) points* if the points in the CSV/TXT file are Grid (local) points and then select the input transformation to transform them to grid points.
 - To assign the transformation later, select *Not applied, this will be defined later*, and then tap *Accept*.

- To create a new display transformation, select *Create new transformation*, tap *Next* and then complete the [required steps](#).
 - To select an existing display transformation, select *Select transformation*, select the display transformation from the list and then tap *Accept*.
6. All the points in the selected file are listed. To check the points that are to be added to the list, do one of the following:
 - Tap *All*. A check mark appears beside every name.
 - Tap the point names. A check mark appears beside the name of each point that you selected.

Note - Points in the CSV/TXT/JOB file that are already in the stake out list do not appear and cannot be added again to the list.
 7. Tap *Add* to add the points to the stake out list.
 8. To select a point for stake out, do one of the following:
 - Tap the point name.
 - Use the controller arrow keys to highlight the point and then tap *Stakeout*.
 9. Do one of the following:
 - In a GNSS survey:
 - If the antenna height is null, select the [Stake method](#), enter the *Antenna height*, and set the *Measured to* field appropriately and then tap *Start*.
 - If the antenna height was configured in the survey style, or recently entered, you are not prompted to enter the antenna height again.
To change the antenna height, tap the antenna icon in the status bar and then enter the new value in the screen that appears. Tap *Accept*.
 - In a conventional survey:
 - To change the target height, tap the target icon in the status bar, tap the antenna height field and then enter the new value in the screen that appears. Tap *Accept*.
 10. Use the [graphical display](#) to navigate to the point.
If required, [edit the design elevation](#).
 11. When the point is within tolerance measure the point.
When the point has been stored, the point is removed from the stake out list and you are returned to the stake out point list.
 12. Select the next point and then repeat the process.

GNSS stake methods

In a GNSS survey, configure the stake method to control how stake out navigation information appears.

In the *Stake* field, select one of the following methods for staking out the point:

- *To the point* - stake out the point with directions from your current position.
- *From fixed point* - stake out the point with cross-track information and directions from another point. Enter a point name in the *From point* field. Select from a list, key in, or measure this value.
- *From start position* - stake out the point with cross-track information and directions from the current position when you start to navigate.
- *From last point staked* - stake out the point with cross-track information and directions from the last point that was staked out and measured. The **staked** point is used, not the design point.
- *Relative to azimuth* - stake out the point with the cross-track information and directions relative to a keyed-in azimuth.

Notes

- *The cross-track function creates a line between the point to be staked out and one of the following: a fixed point, the start position, the last point staked, or a reference azimuth. The General Survey software displays this line, and an extra field (Go left or Go right), in the graphical stake out screen gives the offset to the line.*
- *When the Deltas field is set to Station and offset the Go left or Go right field shows the same information as the H.Offset field.*
- *When the Deltas is set to Station and offset and the Stake method is set to Relative to azimuth, the Go left or Go right field is replaced by the delta Elev (to last) staked point field.*

If the antenna height was already entered, you can configure the Stake methods. From the second row of softkeys in the stake out point list screen, tap *Options*. To see the other softkeys, tap the arrow or press the Shift key.

Editing the design elevation

- The design elevation appears in the bottom right corner of the navigation window. To edit the elevation, tap the arrow. To reload an edited elevation, select *Reload original elevation* from the pop-up menu in the *Design elevation* field.

If the navigation window contains five rows of navigation information, the label for the *Design elevation* field is not shown.

- After staking, you can modify the design elevation in the as-staked deltas screen, depending on the [stake out style sheet](#) being used.

Offsetting a point

When staking a point using the Stake option *To the point* you can stake an offset point defined by an azimuth and offset from the point. You can also define a second offset point on the same azimuth as the first offset point.

1. When navigating to the point, from the second row of softkeys in the graphical display, tap *Offset*.
2. Use the *Offset* option, as shown in the diagram below, to stake out points (1) at an azimuth (2)

from a point (3) and offset by a horizontal distance (4).

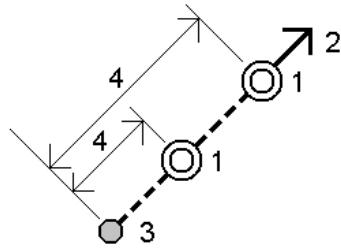

The elevation for each offset point can be defined by:

- *Slope from point* – the elevation is computed by a slope from the elevation of the point selected to stake.
- *Delta from point* – the elevation is computed by a delta from the elevation of the point selected to stake.
- *Key in* – the elevation is keyed in.

Note - If the point has no elevation, the elevation for the offset points must be keyed in.

3. Tap *Accept*.

The map shows the selected point and the first offset point.

4. Use the [graphical display](#) to navigate to the offset point.

5. When the point is within tolerance, measure the point.

When the point has been stored, you are returned to the map. If a second offset point has been defined, the map is updated to show this point.

6. Use the graphical display to navigate to the offset point.

When the second offset point has been measured and stored, the point is removed from the stakeout list and you are returned to the stakeout point list.

7. Select the next point and then repeat the process.

Staking out lines

To stake out a line in an RTK or conventional survey:

1. Do one of the following:

- From the main menu, select *Stakeout / Lines* and then tap the pop-up arrow next to the *Line name* field and select:
 - *List* to view a list of previously defined lines to select from.
 - *Two points* to define the line from two points.
 - *Azimuth* to define the line by a start point and an azimuth.
- From the map:
 - Select two points to define a line, tap and hold on the map and then select *Stake out line* from the menu.
 - Double-tap the line on the map.

- Select the line to be staked out and then tap *Stakeout*, or tap and hold on the map and then select *Stake out line* from the menu.

When selecting a line to stakeout from the map, tap near the end of the line that you want to designate as the start. Arrows are then drawn on the line to indicate the direction. If the direction is incorrect, tap the line to deselect it and then tap it at the correct end to reselect the line in the direction required. Alternatively tap and hold on the map and select *Reverse line direction* from the menu.

Note - If the line has been offset, the offset directions are not swapped when the line direction is reversed.

2. In the *Stake* field, select one of the following options:

- *To the line*
- *Station on the line*
- *Station/offset from line*
- *Slope from line*
- *Station/skew offset from line*

When staking by *Station on the line*, *Station/offset from line* or *Station/skew offset from line*, use the *Sta-* and *Sta+* softkeys to select the station to stake, or tap the pop-up arrow at the *Station* fields to select the start or end station.

3. To review the line definition, tap *Details*.
4. Enter the *Antenna/Target height*, the value of the station to be staked out (if any), and any further details, such as horizontal and vertical offsets. Tap *Start*.
5. Use the [graphical display](#) to navigate to the point.
6. When the point is within tolerance measure the point.

Tips

- When using a GNSS receiver with an in-built tilt sensor, you can:
 - tap *eBubble* to display an electronic bubble
 - configure the survey style to prompt a warning when the pole is outside a specified *Tilt tolerance*
- Tap *Options* to configure the quality control, precision, and *tilt settings*.

To the line

Use this option, as shown in the diagram below, to measure your position (1) relative to a defined line (2).

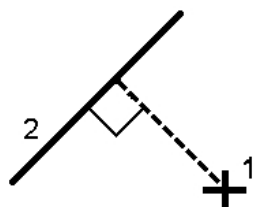

Station on the line

Use this option, as shown in the diagram below, to stake out stations (1) on a defined line at the station interval (2) along the line.

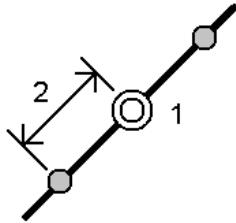

Station/offset from line

Use this option, as shown in the diagram below, to stake out a point (1) perpendicular to a station (3) on a defined line (2) and offset to the left or right by a horizontal distance (4). The design elevation of the point is the same as the elevation of the line at the selected station.

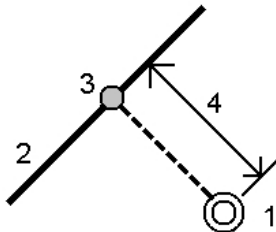

Slope from line

Use this option, as shown in the diagram below, to measure your position relative to a slope (2) defined either side of a defined line (1). Each slope can be defined with a different grade (3).

Use the *Slope left* field and the *Slope right* field to define the type of grade in one of the following ways:

- horizontal and vertical distance
- grade and slope distance
- grade and horizontal distance

The software reports your position relative to the line and the vertical distance as a cut (4) or a fill (5) to the slope.

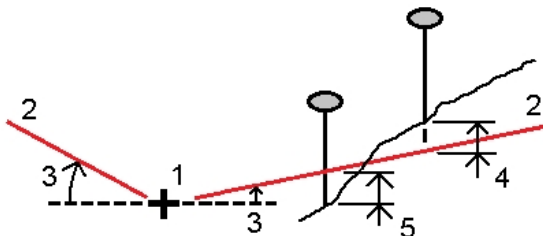

Station/skew offset from line

Use this option, as shown in the diagram below, to stake out a point (1) at a skew (2) from a station (3) on a defined line (4) and offset to the left or right by a skew distance (5). The skew can be defined by a forward or backward delta angle to a line (6) at right angles to the line being staked, or the skew can be defined by an azimuth. The diagram shows a point defined by a skew forward and offset to the right.

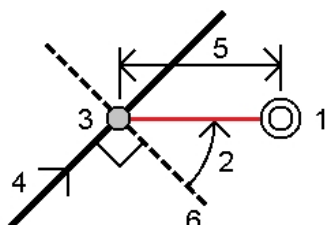

The elevation for the point can be defined by:

- *Slope from line* – the elevation is computed by a slope from the elevation of the line at the entered station
- *Delta from point* – the elevation is computed by a delta from the elevation of the line at the entered station.
- *Key in* – the elevation is keyed in.

Note - If the line has no elevation, the elevation for the point must be keyed in.

Staking out arcs

Follow these steps to stake out an arc in an RTK or conventional survey:

1. Do one of the following:
 - From the main menu, select *Stakeout / Arcs* and then tap the pop-up arrow next to the *Arc name* field and select:
 - *List* to view a list of previously defined arcs to select from.
 - *Two points* to define the arc from two points.
 - *Azimuth* to define the arc by a start point and an azimuth.
 - From the map, select the arc to be staked out. Tap *Stakeout*, or tap and hold on the map and then select *Stakeout* from the menu.

When selecting an arc to stakeout, tap near the end of the arc that you want to designate as the start. Arrows are then drawn on the arc to indicate the direction. If the direction of the arc is incorrect, tap the arc to deselect it and then tap it at the correct end to reselect the arc in the direction required. Alternatively tap and hold on the map and select *Reverse arc direction* from the menu.

Note - If the arc has been offset, the offset directions are not swapped when the arc direction is reversed.

2. In the *Stake* field, select one of the following options:

- *To the arc*
- *Station on the arc*
- *Station/offset from arc*
- *Slope from arc*
- *Station/skew offset from arc*
- *Intersect point of arc*
- *Center point of arc*

When staking by *Station on the arc*, *Station/offset from arc*, or *Station/skew offset from arc*, use the *Sta-* and *Sta+* softkeys to select the station to stake, or tap the pop-up arrow at the *Station* fields to select the start or end station.

3. To review the arc definition, tap *Details*.
4. Enter the *Antenna/Target height*, the value of the station to be staked out (if any), and any further details, such as horizontal and vertical offsets. Tap *Start*.
5. Use the [graphical display](#) to navigate to the point.
6. When the point is within tolerance measure the point.

Tips

- When using a GNSS receiver with an in-built tilt sensor, you can:
 - tap *eBubble* to display an electronic bubble
 - configure the survey style to prompt a warning when the pole is outside a specified *Tilt tolerance*
- Tap *Options* to configure the quality control, precision, and *tilt settings*.

To the arc

Use this option, as shown in the diagram below, to measure your position (1) relative to a defined arc (2).

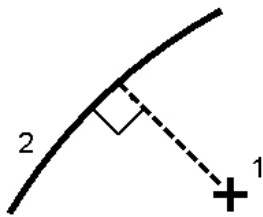

Station on the arc

Use this option, as shown in the diagram below, to stake out points (1) on a defined arc at the station intervals (2) along the arc.

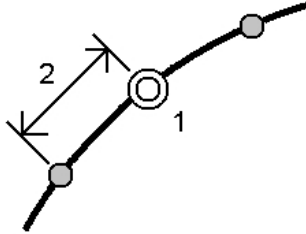

Station/offset from arc

Use this option, as shown in the diagram below, to stake out a point (1) perpendicular to a station (3) on a defined arc (2) and offset to the left or right by a horizontal distance (4). The design elevation of the point is the same as the elevation of the arc at the selected station.

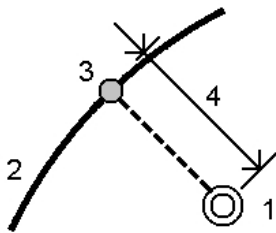

Slope from arc

Use this option, as shown in the diagram below, to measure your position relative to a slope (2) defined either side of a defined arc (1). Each slope can be defined with a different grade (3).

Use the *Slope left* field and the *Slope right* field to define the type of grade in one of the following ways:

- horizontal and vertical distance
- grade and slope distance
- grade and horizontal distance

The software reports your position relative to the arc and the vertical distance as a cut (4) or a fill (5) to the slope.

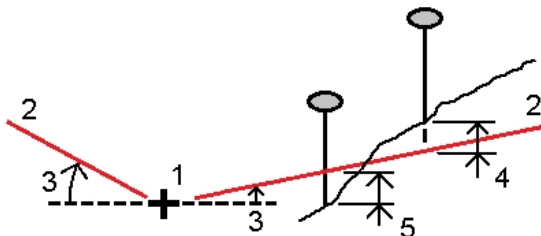

Station/skew offset from arc

Use this option, as shown in the diagram below, to stake out a point (1) at a skew (2) from a station (3) on a defined arc (4) and offset to the left or right by a skew distance (5). The skew can be defined as a forward or backward delta angle to a line (6) at right angles to the arc being staked, or the skew can be defined by an azimuth. The diagram shows a point defined by a skew forward and offset to the right.

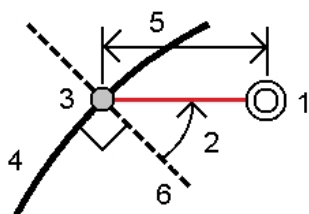

The elevation for the point can be defined by:

- *Slope from arc* – the elevation is computed by a slope from the elevation of the arc at the entered station.
- *Delta from arc* – the elevation is computed by a delta from the elevation of the arc at the entered station.
- *Key in* – the elevation is keyed in.

Note - If the arc has no elevation, the elevation for the point must be keyed in.

Intersect point of arc

Use this option as shown in the diagram below, to stake out the Intersection point (1) of an arc (2).

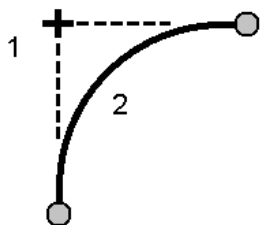

Center point of arc

Use this option, as shown in the diagram below, to stake out the Center point (1) of a defined arc (2).

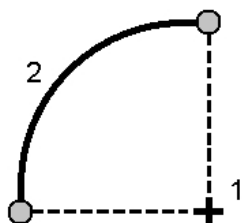

Staking out alignments

The General Survey software supports offsetting and stakeout of alignments, which are sometimes known as polylines.

Alignments always have a horizontal component; the vertical component is optional. If an alignment is created using entities that have elevations, the alignment will have a vertical component.

You can select or create and stake alignments using one of the following methods:

- [Key in point name ranges.](#)
- [Select one or more polylines in graphical view.](#)
- [Selecting an existing alignment from the Stakeout menu](#)
- [Select an existing alignment \(RXL or LandXML\) from the map.](#)
- [Select a series of points in the map.](#) The points can be from the current job, a linked job, or a linked csv file.
- Select a combination of points, lines, arcs, polylines, or alignments in the map.

Tip - To add files from another folder to the list, tap *Add*, navigate to the required folder and then select the file(s) to add.

You can edit alignments using *Key in / Roads*. The horizontal and vertical components are edited individually. If you edit the horizontal alignment, you must check if the vertical alignment also needs editing.

Creating an alignment by keying in a point name range

1. From the main menu, select *Stakeout / Alignments*.

You can stake an existing alignment or key in a new alignment. If the *Point range* field is not visible, tap *New* to enter a new alignment.

2. Enter the point names that define the alignment.

The following name range techniques are supported:

Enter	Result
1,3,5	Creates a line between points 1 to 3 to 5
1-10	Creates lines between all points from 1 through 10
1,3,5-10	Creates a line between points 1 to 3, to 5, and 5 through 10
1(2)3	Creates an arc between points 1 and 3, through point 2
1(2,L)3	2 (Radius point), L (left) or R (right) Creates a Left hand arc between points 1 and 3, with point 2 as the radius point
1(100,L,S)3	1 to 3, radius=100, L (left) or R (right), L (large) or S (small) Creates a Left hand Small arc between points 1 and 3 with a radius of 100

- To store the alignment, select the *Store alignment* check box, enter an *Alignment name*, enter a *String name* (if required) and a *Start station* and *Station interval*, and then tap *Next*.

This takes you to stakeout.

Alignments are stored as RXL files. If you save the alignment, you can easily stake it again, view it in the map, and share it with other jobs and with other controllers.

Tip - To offset the alignment, tap *Offset*. If the *Store alignment* check box is enabled, tap *Next* to store the alignment and go to stakeout. To store the alignment without going to stakeout, tap *Store*.



- You can stake an alignment by the following methods:

[Station on alignment](#)

[Side slope from alignment](#)

[Station/skew offset from alignment](#)

Staking a polyline from a DXF, STR or SHP file

- From the main menu, tap *Map*. In the 2D map, tap the up arrow to access more softkeys and then tap *Layers*. In the 3D map, tap  and then select *Layers*.
- Tap the file name once to make it visible; tap it again to make it selectable.
Tap  to expand the layers within a DXF or STR file and to allow individual selection of layers to be visible and selectable.
- Tap *Accept* to confirm the selection and return to the map.
- Tap the polyline you want to stake.
Tap the end of the polyline that you want to be the start of the polyline.
- To stake the polyline/alignment:
 - Tap *Stakeout*, or tap and hold on the map screen, and then select *Stake out alignment*. This allows you to stake the polyline without storing the alignment.
 - Tap and hold on the map screen and then select *Create/Offset alignment*. Complete the fields as required and then tap *Next*. You can then do one or more of the following:

- stake the polyline
- store the polyline as an alignment
- offset and stake the alignment
- store the offset alignment
- store the offset alignment and store node points at vertices
- stake the alignment or offset alignment

You can stake a polyline directly from a DXF, STR or SHP file, but all polylines are converted to alignments for stakeout and when saved to the controller.

6. You can stake an alignment by the following methods:

[Station on alignment](#)

[Side slope from alignment](#)

[Station/skew offset from alignment](#)

Selecting an existing alignment from the Stakeout menu

Note – You can stake a LandXML alignment only by selecting it from the map. See [Staking an existing alignment from an RXL or LandXML file selected from the map](#).

1. From the main menu, select *Stakeout / Alignments*.
2. Select the alignment to stake and then tap *Next*.
3. You can stake an alignment by the following methods:

[Station on alignment](#)

[Side slope from alignment](#)

[Station/skew offset from alignment](#)

Staking an existing alignment from an RXL or LandXML file selected from the map

1. From the main menu, tap *Map*. In the 2D map, tap the up arrow to access more softkeys and then tap *Layers*. In the 3D map, tap  and then select *Layers*.
2. Tap the file name once to make it visible, tap it again to make it selectable.
3. Tap *Accept* to confirm the selection and return to the map.
4. Tap the alignment you want to stake.
The direction of an alignment is defined when it is created; it cannot be changed.
5. To stake the alignment:
 - Tap *Stakeout*, or tap and hold on the map screen, and then select *Stake out alignment*. This takes you directly to Stake out alignment.
 - Tap and hold on the map screen and then select *Create/Offset alignment*. Complete the fields as required and then tap *Next*. You can then do one or more of the following:

- stake the polyline
 - store the polyline as an alignment
 - offset and stake the alignment
 - store the offset alignment
 - store the offset alignment and store node points at vertices
 - stake the alignment or offset alignment
6. You can stake an alignment by the following methods:
- [Station on alignment](#)
 - [Side slope from alignment](#)
 - [Station/skew offset from alignment](#)

Staking an alignment defined by points selected from the map

1. From the main menu, tap *Map*.
2. Select the points defining the alignment.
3. To stake the alignment:
 - Tap and hold on the map screen, and then select *Stake out alignment*. This takes you directly to Stake out alignment.
 - Tap and hold on the map screen and then select *Create/Offset alignment*. Complete the fields as required and then tap *Next*. You can then do one or more of the following:
 - stake the polyline
 - store the polyline as an alignment
 - offset and stake the alignment
 - store the offset alignment
 - store the offset alignment and store node points at vertices
 - stake the alignment or offset alignment
4. You can stake an alignment by the following methods:
 - [Station on alignment](#)
 - [Side slope from alignment](#)
 - [Station/skew offset from alignment](#)

Offsetting alignments

You can create an offset alignment from a keyed-in alignment, an alignment from an RXL or LandXML file, or a polyline from a DXF, STR, or SHP file.

When creating an offset alignment, you can stake the alignment without saving it, or you can give the alignment a name and then save the offset alignment as an RXL file. You can also create and save node points at the vertices of the horizontal alignment.

Note – You can stake a LandXML alignment only by selecting it from the map. See [Staking an existing alignment from an RXL or LandXML file selected from the map](#).

To offset and stake an alignment:

1. From the main menu, select *Stakeout / Alignments*.

You can select an existing alignment or key in a new alignment:

- To select an existing alignment, tap the alignment name (if the *Select an alignment* screen is displayed). If the *Point range* field is displayed, tap *Select* to view the alignments already on the controller.
- To key in a new alignment, enter the point names that define the alignment (if the *Key in alignment* screen is displayed). If the *Select an alignment* screen is displayed, tap *New* to enter the point range.

For more information, see the section [above](#).

2. To offset an alignment, tap *Offset*.
3. Enter the offset distance. To offset to the left, enter a negative value.
4. To store the offset alignment, enable the *Store alignment* check box, enter an *Alignment name*, enter a *String name*, if required, and then tap *Next*. The alignment is stored as an RXL file.
5. To store node points at the vertices of the offset alignment, enable the *Store points at nodes* check box, enter a *Start point name*, enter a *Code*, if required, and then tap *Next*.
Selecting *Next* stores the alignment, if the *Store alignment* check box is enabled, and takes you to stakeout. To store an alignment without going to stakeout, tap *Store*.
6. You can stake an alignment by the following methods:

[Station on alignment](#)

[Side slope from alignment](#)

[Station/skew offset from alignment](#)

An offset alignment will have a vertical component if the vertical geometry of the original alignment is coincident with the horizontal geometry and the vertical geometry consists only of points. The offset vertical geometry cannot include curves. If the vertical geometry of an alignment cannot be offset, only the horizontal component will exist in the offset alignment. You cannot offset an alignment that includes transitions.

Staking out relative to a DTM

You can stake an alignment relative to a **DTM**. When you do this the horizontal navigation is relative to the alignment but the cut/fill delta value shown is to a selected DTM.

1. From the main menu, select *Stakeout / Alignments* and then select the alignment to stake.
2. Tap *Options* and in the Display group select the DTM and then set the *Display cut/fill* field to *DTM*. If required, specify a vertical offset to the DTM. Tap  and select whether the offset is to be applied vertical or perpendicular to the DTM.

Notes

- The heading for the displayed cut/fill value changes to *V.dist DTM*.
- When a horizontal construction offset is applied, the cut/fill value reported is to the DTM at the position selected for stakeout and not to the DTM at your current position.

Station abbreviations

The General Survey software uses the following abbreviations in the *Station* field pop-up menu.

Abbreviation	Meaning	Abbreviation	Meaning
CS	Curve to transition	SS	Transition to transition
PC	Point of curvature (Tangent to curve)	ST	Transition to tangent
PI	Point of intersection	TS	Tangent to transition
PT	Point of tangent (Curve to tangent)	VCE	Vertical curve end
AS	Alignment start	VCS	Vertical curve start
AE	Alignment end	VPI	Vertical point of intersection
SC	Transition to curve	XS	Regular sections
Hi	Vertical curve high point	Lo	Vertical curve low point

Staking out a station on an alignment

1. In the *Stake* field, select *Station on alignment*.
2. Select a *Station* to stake and then specify the *Station interval*.
You can select a station using one of the following methods:
 - Select from the list in the *Station* field pop-up menu.
 - Key in a value.
 - Tap *Sta+* or *Sta-* to select the next/previous station.
3. If required, enter an *Offset*.
4. To edit the design elevation, tap the arrow. To reload an edited elevation, select *Reload original elevation* from the pop-up menu in the *Design elevation* field.
Note - If the position that you select for stakeout has no elevation, the *Design elevation* field becomes available. Enter an elevation into this field.
5. If required, enter values in the *Construction offsets* fields.
6. To change target or antenna heights, tap the target icon in the status bar.
7. Tap *Stakeout* and then use either the plan or *cross section* graphical display to navigate to the point.

The graphical display shows the:

- Station value
- Offset
- Elevation of your current position (shown in blue)
- Design elevation of the selected position (shown in red if edited)
- Construction offset values

The base of the screen displays the navigation deltas.

Tips

- To select the delta display, tap the arrow to the left of the navigation deltas.
 - Tap *Options* for further delta display options.
 - To view the [cross section](#) of your current position, tap the icon at the bottom right of the graphics window. Alternatively, press the [Tab] key on the controller to switch between the plan view and the cross section view.
 - To access the status bar while the graphics window is in widescreen mode, tap the arrow on the far right of the screen. The status bar appears for approximately three seconds, after which time the window returns to widescreen.
 - To change the widescreen mode tap and hold in the graphics window and then select *Widescreen*.
8. When the point is within tolerance measure the point.

Tips

- When using a GNSS receiver with an in-built tilt sensor, you can:
 - tap *eBubble* to display an electronic bubble
 - configure the survey style to prompt a warning when the pole is outside a specified *Tilt tolerance*
- Tap *Options* to configure the quality control, precision, and *tilt settings*.

Staking out the side slope from an alignment

1. In the *Stake* field, select *Side slope from alignment*.
2. Enter a value in the *String name* field (this step is optional).

Tip - The annotation entered in the *String name* field is assigned to the end of the side slope and is displayed during stakeout.
3. Select a *Station* to stake and then specify the *Station interval*.

You can select a station using one of the following methods:

 - Select from the list in the *Station* field pop-up menu.
 - Key in a value.
 - Tap *Sta+* or *Sta-* to select the next/previous station.
4. To define the hinge, select a *Hinge derivation* method and then complete the appropriate fields.

Note - If the alignment consists of only a horizontal alignment, the only hinge derivation method available is *Offset and elevation*.
5. To define the *Side slope*, enter appropriate values in the *Cut slope*, *Fill slope*, and *Cut ditch width* fields.

Note - *Cut and fill slopes are expressed as positive values*.

Tip - To define a side slope with only a cut or fill slope, leave the other slope value field as '?'.

6. If required, enter values in the *Construction offsets* fields.
7. To change target or antenna heights, tap the target icon in the status bar.
8. Tap *Stakeout* and then use either the plan or *cross section* graphical display to navigate to the point.

The graphical display shows the:

- Station value
- Offset
- Side slope value defined by your current position (shown in blue)
- Design side slope value
- Elevation of your current position (shown in blue)
- Construction offset values

The base of the screen displays the navigation deltas.

When you are within 3m of the target the graphical display in the plan view shows your current position along with the target. Also displayed is a dashed line that connects the side slope catch position, (the point where the side slope intersects with the ground), to the side slope hinge position.

Tips

- To select the delta display, tap the arrow to the left of the navigation deltas.
 - Tap *Options* for further delta display options.
 - To view the *cross section* of your current position, tap the icon at the bottom right of the graphics window. Alternatively, press the [Tab] key on the controller to switch between the plan view and the cross section view.
 - To access the status bar while the graphics window is in widescreen mode, tap the arrow on the far right of the screen. The status bar appears for approximately three seconds, after which time the window returns to widescreen.
 - To change the widescreen mode tap and hold in the graphics window and then select *Widescreen*.
 - When you are within 3m of the target the graphical display in the plan view shows your current position along with the target. Also displayed is a dashed line that connects the side slope catch position, (the point where the side slope intersects with the ground), to the side slope hinge position.
9. When the point is within tolerance measure the point.

Tips

- When using a GNSS receiver with an in-built tilt sensor, you can:
 - tap *eBubble* to display an electronic bubble
 - configure the survey style to prompt a warning when the pole is outside a specified *Tilt tolerance*
- Tap *Options* to configure the quality control, precision, and *tilt settings*.

Notes

- If you are staking to a [catch point](#) with construction offsets, navigate to the catch point and then tap *Apply* to add the construction offsets. You are prompted to apply the offsets from your current position. If you are not on the catch position, select *No*, navigate to the catch position and then tap *Apply* again.

If you want to store the catch position and the construction offset, see [Specifying construction offsets](#).

- To also stake the appropriate hinge position, tap *Select>>* and select either the *Hinge point (Cut)* or *Hinge point (Fill)* option.

Staking out a station at a skew offset from an alignment

1. In the *Stake* field, select *Station/skew offset from alignment*.
2. Select a *Station* to stake and then specify the *Station interval*.

You can select a station using one of the following methods:

- Select from the list in the *Station* field pop-up menu.
- Key in a value.
- Tap *Sta+* or *Sta-* to select the next/previous station.

3. Enter skew and offset values.

As shown in the diagram below, the point to stake (1) is defined from the station (3) by an offset (5) along the skew (2). The skew can be defined by a forward or backward delta angle to a line (6) at right angles to the alignment being staked (4), or the skew can be defined by an azimuth. The diagram shows a point defined by skew forward and offset to the right.

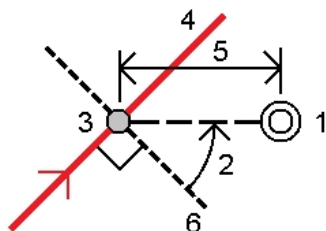

4. The elevation for the point can be defined by:
 - *Slope from alignment* – the elevation is computed by a slope from the elevation of the alignment at the entered station.
 - *Delta from alignment* – the elevation is computed by a delta from the elevation of the alignment at the entered station.
 - *Key in* – the elevation is keyed in.

Note – If the alignment has only a horizontal alignment, the elevation for the point can be defined only by *Key in*.

5. If required, enter values in the [Construction offsets](#) fields.

Note – *If the computed position is before the start or beyond the end of the alignment the point cannot be staked.*

6. To change target or antenna heights, tap the target icon in the status bar.
7. Tap *Stakeout* and navigate to the point.

The graphical display shows the:

- Station value
- Skew offset and delta angle/azimuth
- Elevation of your current position (shown in blue)
- Design elevation of the selected position
- Construction offset values

The base of the screen displays the navigation deltas.

Tips

- To select the delta display, tap the arrow to the left of the navigation deltas.
 - Tap *Options* for further delta display options.
 - When staking a station at a skew offset, the cross section view is unavailable.
 - To access the status bar while the graphics window is in widescreen mode, tap the arrow on the far right of the screen. The status bar appears for approximately three seconds, after which time the window returns to widescreen.
 - To change the widescreen mode tap and hold in the graphics window and then select *Widescreen*.
8. When the point is within tolerance measure the point.

Tips

- When using a GNSS receiver with an in-built tilt sensor, you can:
 - tap *eBubble* to display an electronic bubble
 - configure the survey style to prompt a warning when the pole is outside a specified *Tilt tolerance*
- Tap *Options* to configure the quality control, precision, and *tilt settings*.

Hinge derivation methods

The following diagram explains the three hinge derivation methods:

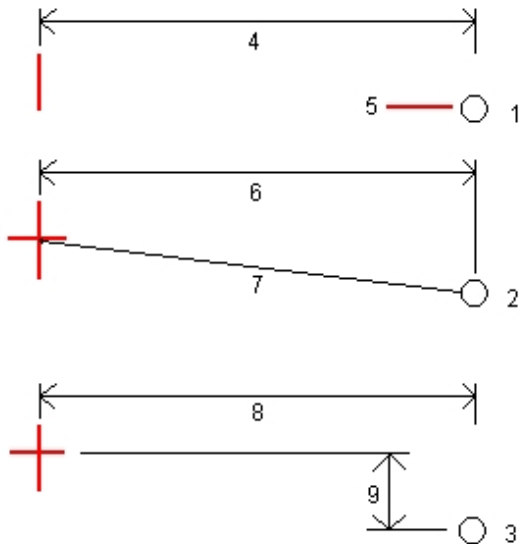

Key to the above diagram:

- 1 - Offset and elevation. Enter an offset (4) from the horizontal alignment, and the elevation (5) of the hinge position.
- 2 - Offset and slope. Enter an offset (6) from the horizontal alignment, and the slope value (7) from the intersection of the horizontal and vertical alignments to the hinge position.
- 3 - Offset and vertical distance. Enter an offset (8) from the horizontal alignment, and the vertical difference (9) from the intersection of the horizontal and vertical alignments to the hinge position.

Cross section view

The cross section that appears is orientated in the direction of increasing station. Your current position and the target are shown. If the target has construction offsets specified, the smaller single circle indicates the selected position and the double circle indicates the selected position adjusted for the specified construction offset(s). The construction offset(s) appear as green lines.

Specifying construction offsets

A point to be staked can be offset by a:

- [Horizontal offset](#)
- [Vertical offset](#)

A construction offset is indicated in the graphical display by a green line, with the double circle indicating the selected position adjusted for the specified construction offset(s).

Tips

- Construction offsets are job-specific. That is, a construction offset specified for an alignment is not used for the same alignment when it is accessed from a different job.
- Construction offsets are not alignment-specific. That is, a construction offset specified for an alignment is used for all alignments in the same job.
- Construction offsets are not survey session-specific. That is, a construction offset specified for an alignment is used for subsequent survey sessions.

Horizontal construction offsets

When staking a station on the alignment or a station at a skew offset from the alignment you can apply a horizontal construction to a point where:

- A negative value offsets the point to the left of the alignment.
- A positive value offsets the point to the right of the alignment.

When staking a station offset from the alignment, or a side slope, you can apply a horizontal construction to a point where:

- A negative value offsets the point toward the alignment (in).
- A positive value offsets the point away from the alignment (out).

When staking a catch point, use the advanced pop-up arrow () to specify if the offset is to be applied:

- Horizontal
- At the slope of the previous element in the cross section

The following diagram shows a *Horizontal offset (1)* and *Slope previous offset (2)* applied to the catch point (3). For the *Slope previous* option, the slope of the offset is defined by the slope of the side slope (4). The *Vertical offset* value in the diagram is 0.000.

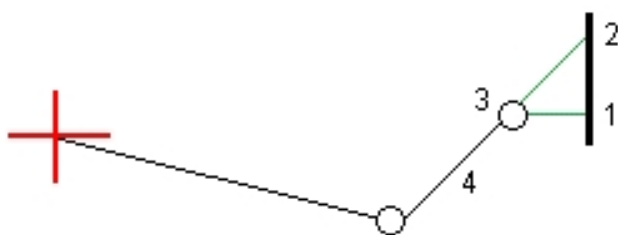

Notes

- For points with zero offset, you cannot apply construction horizontal offsets at the slope value of the previous template element.
- When staking a station at a skew offset from the alignment, the horizontal construction offset is applied along the skew, not at right angles to the alignment.
- Construction offsets are not automatically applied to a side slope offset. For more information, see staking a [Catch point](#).

- When you stake a side slope, select the *Store both catch and construction offset* check box if you want to measure **and** store the catch position.

Vertical construction offsets

You can apply a vertical construction offset to a point where a:

- Negative value offsets the point vertically down.
- Positive value offsets the point vertically up.

When staking a side slope from the alignment, in the *Vertical offset* field, use the advanced pop-up arrow (⌵) to specify if the offset is to be applied:

- Vertically
- Perpendicular to the element in the cross section before the point being staked

The following diagram shows a *Vertical offset* applied vertically (1) and a *Vertical offset* applied perpendicular (2) to the side slope (3).

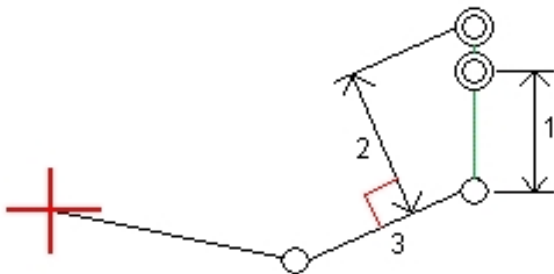

Specifying a side slope

A side slope is defined by a *Cut slope* (1), *Fill slope* (2), and *Cut ditch width* (3) fields.

The following diagram shows the side slope.

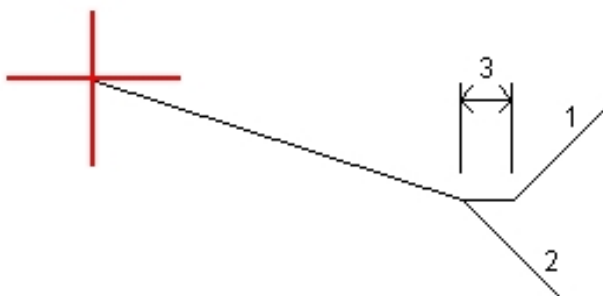

Catch point

The catch point is the point where the design side slope intersects with the ground.

The actual intersection position of the side slope with the existing ground surface - the catch point - is determined iteratively (by repetition). The General Survey software calculates the intersection of a horizontal plane passing through the current position, and either the cut or fill side slope, as shown in the following diagram, where x_n is the *Go Right/Left* value.

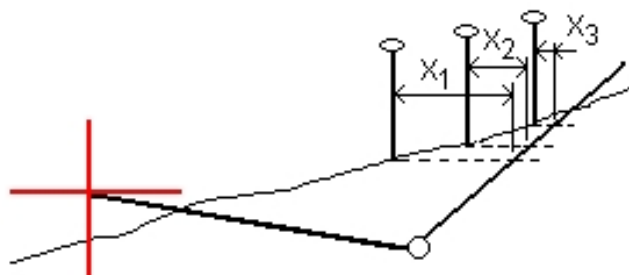

The graphical display in the plan view, shows the calculated catch position. The calculated slope value (in blue) and the design slope value appears at the top of the screen.

To view the [cross section](#) of your current position, tap the icon at the bottom right of the graphics window. Alternatively, press the [Tab] key on the controller to switch between the plan view and the cross section view.

The cross section is displayed looking in the direction of increasing station. Your current position and the calculated target are indicated. A line is drawn (in blue) from the hinge position to your current position to indicate the calculated slope.

If the catch point has construction offsets specified, these appear in the cross-section view as green lines. The smaller single circle indicates the calculated catch position and the double circle indicates the selected position adjusted for the specified construction offset(s). The construction offsets appear only after you have applied them.

From the *Confirm staked deltas* screen (or *Review job*) tap [Report](#) to view the *Catch point deltas report* screen.

The Select softkey

The *Select* softkey provides the following options related to staking a side slope.

Option	Description
<i>Catch point (Auto)</i>	The General Survey software selects the side slope (cut or fill) to intersect with the ground. This is the default.
<i>Catch point (Cut)</i>	Fixes the side slope as a cut side slope.
<i>Catch point (Fill)</i>	Fixes the side slope as a fill side slope.
<i>Hinge point (Cut)</i>	Stakes out the base of the cut side slope. This is the most direct way to select the hinge point if the template includes a ditch offset.
<i>Hinge point (Fill)</i>	Stakes out the start of the fill side slope.

Catch point staked deltas

If you have the *View before storage* check box in the *Stakeout* options selected, the *Confirm staked deltas* screen appears before you store the point.

The General Survey software supports user-definable stakeout reports, which enable you to configure the display of staked information on the *Confirm staked deltas* screen that appears when you enable *View before storage*. For more information, see [As-staked point details](#).

Note - The value in the *S.Distance to hinge + Constr off* field includes any construction offset values specified and reports the slope distance from the hinge to the as-staked position. The value is null (?) if there is no horizontal construction offset specified or the horizontal construction offset is applied horizontally.

Tip - Tap *Report* to view the *Catch point deltas report* screen. This screen shows the horizontal and vertical distances from the hinge and the centerline. If the side slope includes a cut ditch, the report includes the hinge position at the toe of the cut slope. The reported values exclude any construction offset specified.

The following diagram explains some of these fields.

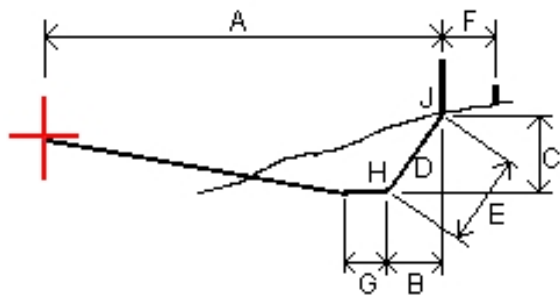

Where:

A	=	Distance to center line
B	=	Horizontal distance to hinge point
C	=	Vertical distance to hinge point
D	=	Slope
E	=	Slope distance to hinge point
F	=	Horizontal construction offset
G	=	Ditch offset
H	=	Hinge point
J	=	Catch point

Digital terrain models (DTMs)

A DTM is an electronic representation of a 3D surface. The General Survey software supports gridded (.dtm), triangulated (.ttm) DTMs, and triangulated DTMs in a LandXML file.

Note - DTMs in a LandXML file are only supported in the Map, not in stakeout.

When a DTM is enabled in the Map, a color gradient shows the elevation changes. To disable the color gradient and show only an outline of the DTM, go to *Options* and then clear the *Display color gradient* check box.

When you specify a DTM, you can view the cut and fill relative to the DTM. You must define a projection and datum transformation before you use a DTM in a GNSS or conventional survey.

When you specify an offset to raise or lower the DTM, you can select whether the offset is to be applied vertical or perpendicular to the DTM.

Note - When the offset is applied perpendicular to the DTM, the cut/fill value is computed using the following steps:

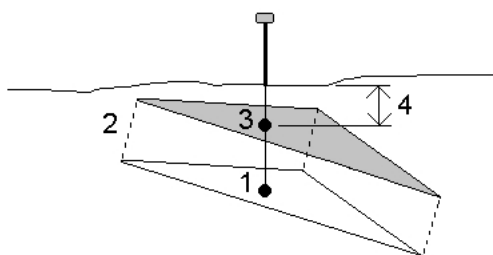

1. Determine the triangle that the current position lies on (1).
2. Offset that triangle at a right angle by the specified offset value (2) to define a new triangle.
3. Compute the elevation of the same position on the new triangle (3).
4. Compute the cut/fill value from the computed elevation to the staked position (4).

Staking out a DTM

1. Transfer a DTM file into the General Survey software then select *Stakeout / DTMs*.
2. Select the file to be used.

Note - All DTM files from all folders are listed.

3. If necessary, specify an offset to raise or lower the DTM. Tap  and select whether the offset is to be applied vertical or perpendicular to the DTM.
4. To change target or antenna heights, tap the target icon in the status bar.
If the target or antenna height have not been defined, the elevation and cut/fill will be null (?).
5. Tap *Start*. The stakeout [graphical display](#) screen appears, displaying the coordinates of the current position and the distance above (cut) or below (fill) the DTM.

Note - Unless you are using a conventional instrument that supports tracking (for example, a Trimble 5600), the values appear only after you have taken a distance measurement.

6. When the point is within tolerance, measure the point.

Tips

- When using a GNSS receiver with an in-built tilt sensor, you can:
 - tap *eBubble* to display an electronic bubble
 - configure the survey style to prompt a warning when the pole is outside a specified *Tilt tolerance*
- Tap *Options* to configure the quality control, precision, and *tilt settings*.

When staking out the DTM, if you are outside the extent of the DTM or in a "hole", the DTM elevation and cut/fill will be null (?).

Showing the cut/fill to a DTM

Showing the cut/fill to a DTM when staking out a point, line, arc, alignment, or road

1. Tap *Options* in the *Stakeout* screen.
2. Select the *Display cut/fill to DTM* check box and specify the model.
3. Tap  and select whether the offset is to be applied vertical or perpendicular to the DTM.

Note - This does not apply to the *Slope from line* or *Slope from arc* stake methods.

Showing the cut/fill to a DTM in the map

1. Transfer a DTM file to the appropriate [project folder](#) on the controller.
2. From the main menu, tap *Map*. In the 2D map, tap the up arrow to access more softkeys and then tap *Layers*. In the 3D map, tap  and then select *Layers*.
3. Tap the DTM file once to select the file and view it in the map; tap the DTM file name again to make it active. Tap *Accept* to return to the map.

When the DTM is active and the map has a position on the DTM, the DTM elevation, and the distance above (cut) or below (fill) the DTM appear in the map screen.

Tip - For the Trimble tablet the elevation of your current position is also displayed in the map screen.

4. If necessary, specify an offset to raise or lower the DTM. Tap  and select whether the offset is to be applied vertical or perpendicular to the DTM. The offset can be configured in *Options* when you select the DTM file. When defined, the offset also appears in the Map.
5. To change target or antenna heights, tap the target icon in the status bar.

If the target or antenna height have not been defined, the elevation and cut/fill will be null (?).

Survey Settings

Settings menu

Use *Settings* from the Trimble Access menu to configure common configuration settings that are shared among multiple programs.

The following programs use common configuration settings that are available from Settings:

- Trimble Access General Survey
- Trimble Access Roads
- Trimble Access Tunnels
- Trimble Access Mines

Use the Survey styles menu to:

- Create and edit [survey styles](#)

Use the Templates menu to:

- Create, edit, rename, or delete a [template](#).
- [Import](#) a template from another job.

Use the Connect menu to:

- Configure the [Internet setup](#)
- Create [GNSS contacts](#) for use with cellular modems
- Configure [Auto connect](#) options
- Configure Trimble servo total station [Radio settings](#)
- Configure [Bluetooth](#) connections
- Configure the [Wi-Fi image transfer](#) settings. Only available if you are using a controller with Wi-Fi image transfer software installed.
- Calibrate the controller's internal [compass](#), if available
- Configure [Auxiliary GPS](#) options

Use the Feature library menu to:

- Create and edit [feature libraries](#)

Use the Language menu to:

- Change the [language](#).
- Switch on or off [sound events](#).

- Switch on or off the Trimble keyboard (supported third-party Windows computers only).

Survey styles

Survey styles define the parameters for configuring and communicating with your instruments, and for measuring and storing points. In a GNSS survey, the survey style instructs the base and rover receivers to perform the functions required for a specific [survey type](#). This whole set of information is stored as a template that can be called up and re-used when necessary.

You can use the styles supplied with the system without configuring them, but you can change default settings as required.

Note - *The 5600 3600 style works with both the Trimble 5600 and Trimble 3600 instruments. General Survey detects the instrument that you are connected to and automatically configures the appropriate controls.*

In a new system, a number of Survey styles are created automatically, and their display properties are controlled through options that are not initially enabled. Options are automatically enabled when the controller software auto-connects to the instrument. To control the options manually, tap *Settings / Survey styles* from the Trimble Access menu and then tap the *Options* softkey.

You can set the software options and the [auto-connect](#) options independently of each other. For example, if you clear the *Trimble GNSS receiver* check box in the *Auto connect options* dialog, that does not disable the *GNSS surveying* option in the software *Options* dialog. However, if the auto-connect options are disabled, then the software options cannot be automatically enabled, because it is the auto-connect process that detects the instrument and then configures the appropriate software options.

Configure the style if the defaults do not suit your needs. To modify the survey style, tap *Settings* from the Trimble Access menu and then select *Survey styles*.

Locking a survey style

You can lock Survey Styles to prevent them from being edited in the field. To do this:

1. Use Windows Mobile Device Center to establish a connection between the controller and your office computer.
2. Navigate to the [Mobile Device / My Windows Mobile-Based Device / Trimble Data / Systems Files] folder.
3. Copy the required style file to your office computer.
4. Select the file, right-click it and then select [Properties].
5. From the [Properties / General] tab, select the [Read-only] check box.
6. Tap OK.
7. Copy the file back to the [Systems Files] folder on your controller.

Select *Settings / Survey Styles* and note the lock symbol to the left of the style name indicating that you cannot edit this style.

Note - *A locked style will be updated to reflect any changes made during the auto-connect cycle when connecting to an instrument.*

Tip - You can edit a copied survey style.

For more information, see:

[Integrated surveys](#)

[Configuring conventional survey styles](#)

[Configuring GNSS survey styles](#)

Survey types

Your survey type will depend on available equipment, field conditions, and the results required. Configure the survey type when you create or edit a survey style.

To do this:

1. From the Trimble Access menu, tap *Settings / Survey styles / <Style name> / Base options*.
2. Change the *Type* field as required.
3. Do the same for *Rover options*.

Note - *General Survey* uses the settings from the selected survey style when you start the survey. *General Survey* will check the style settings to ensure that they are appropriately configured for the equipment that you are connected to. For example, if GLONASS is enabled in the survey style it will check if the GNSS receiver or antenna you are connected to also supports GLONASS. If *General Survey* detects an incorrect setting, or if it detects that the settings in the survey style have never been checked, it will ask the user to confirm or correct the settings. Any changed settings are saved to the survey style.

For more information, see:

[Integrated surveys](#)

[Configuring conventional survey styles](#)

[Configuring GNSS survey styles](#)

Configuring the survey style to use a laser rangefinder

To measure points or distances using a laser rangefinder connected to the controller, first configure the laser rangefinder in your survey style.

1. From the Trimble Access menu, tap *Settings / Survey styles*.
2. Highlight a survey style and tap *Edit*.
3. Select *Laser rangefinder*.
4. Select one of the instruments in the *Type* field.
5. If necessary, configure the *Controller port* and *Baud rate* fields.

The default value in the *Baud rate* field is the manufacturer's recommended setting. If the laser is a model with which the *General Survey* software can automatically take a measurement when you tap *Measure*, edit the *Auto measure* field.

6. If required, select the *Auto store* point check box.

7. Tap *Enter*. The precision fields contain the manufacturer's precision values for the laser. They are for information only.

Trimble controllers support Bluetooth wireless connection to some laser rangefinders. If you use a Bluetooth wireless connection to a laser rangefinder, configure the Bluetooth wireless connection settings. For more information, see [Bluetooth](#).

Laser measurements can be displayed as vertical angles measured from the zenith or inclinations measured from horizontal. Select a display option in the Laser VA display field of the Units screen. For more information, see [Units](#).

If you are using the LTI TruPulse 200B or 360B, you can select the *Low quality targets* check box. When the check box is not selected, measurements that are flagged by the laser rangefinder as low quality are rejected and you will need to take another measurement.

Before using the laser with the controller, configure the laser options. The following table shows the configuration for each laser that is supported by General Survey.

Laser	Laser setting
Trimble Geo7X integrated rangefinder	<p>The integrated rangefinder is selected by default in the survey style.</p> <p>Enter the laser height in the <i>Laser height</i> field in the General Survey software. In the laser rangefinder application, select the <i>Position / Offset</i> method when measuring laser points.</p> <p>Note - <i>When calibrating the sensors, make sure you perform the calibration away from all sources of magnetic interference.</i></p>
Trimble LaserAce 1000	<p>Bluetooth model connection details:</p> <p>There is no Bluetooth configuration on the LaserAce 1000, it is always enabled. When the LaserAce 1000 is detected during the scan for Bluetooth devices, an authentication request dialog appears. You must enter the PIN number set in the laser rangefinder (default PIN = 1234).</p>
Bosch DLE 150	<p>When the Bosch DLE 150 is detected, an authentication request dialog appears. You must enter the PIN number set in the laser rangefinder.</p>
LTI Criterion 300 or LTI Criterion 400	<p>From the main menu, press the down arrow or up arrow key until the <i>Survey</i> menu appears and then tap <i>Enter</i>. Select <i>Basic measurements</i> and tap <i>Enter</i>. A screen showing the fields <i>HD</i> and <i>AZ</i> appears.</p>
LTI Impulse	<p>Set up the laser to operate in CR 400D format. Make sure that a small "d" is displayed on the screen. (If necessary, press the Fire2 button on the laser).</p>
LTI TruPulse 200B/360B	<p>Set the TruPulse mode to either [Slope Distance], [Vertical Distance], or [Horizontal Distance].</p>
Laser Atlanta Advantage	<p>Set the <i>Range/Mode</i> option to <i>Standard (Averaged)</i> and the <i>Serial/Format</i> option to <i>Trimble Pro XL</i>.</p> <p>Set <i>Serial / Remote / Trigger Character</i> to 7 (37h). (The remote trigger works only when connected via a cable, not when using Bluetooth wireless technology.)</p> <p>Set <i>Fire Time</i> to the delay required (not zero or infinity).</p> <p>Set <i>Serial T-Mode</i> to <i>Off</i>.</p>

Laser	Laser setting
LaserCraft Contour XLR	Set the LaserCraft mode in the laser. If you connect through Bluetooth wireless technology, you also need to change the baud rate setting on the laser rangefinder to 4800.
Leica Disto memo/pro	Set the unit to meters or feet, not feet and inches.
Leica Disto Plus	You must enable Bluetooth wireless technology on the Leica Disto Plus before you run a Bluetooth scan. To do this, set <i>System / Power / Bluetooth</i> to <i>On</i> . If automeasure is switched off: <ol style="list-style-type: none"> 1. To take the measurement, press the [Dist] key on the laser rangefinder. 2. Press the [2nd] key. 3. To transfer the measurement to the controller, press one of the eight direction arrow keys.
MDL Generation II	No special settings are required.
MDL LaserAce	Set the <i>Data record</i> format to <i>Mode 1</i> . When you use the angle encoder, set the magnetic declination to zero in the General Survey software. The angle encoder in the LaserAce laser corrects for the magnetic declination. Set the baud rate to 4800. Bluetooth model connection details: There is no Bluetooth wireless technology configuration on the MDL LaserAce, it is always enabled. When the MDL LaserAce is detected during the scan for Bluetooth devices, an authentication request dialog appears. You must enter the PIN number set in the laser rangefinder (default PIN = 1234).

Note - You must configure the laser rangefinder to update the inclinometer and slope distance readings after each measurement.

For more information, see:

[Measuring points with a laser rangefinder](#)

Echo sounder instruments

General Survey software supports as standard the following models of bathymetric echo sounders:

Echo sounder	Echo sounder settings
CeeStar Basic High Freq	CeeStar Dual Frequency echosounders, BASIC output format, when the High Frequency depth is to be stored. The unit must be set to output 'prefixes' and not 'commas' in the output data [Menu / Advanced / Prefix / Comma outfm] set to [Use prefix].
CeeStar Basic Low Freq	CeeStar Dual Frequency echosounders, BASIC output format, when the Low Frequency depth is to be stored. The unit must be set to output 'prefixes' and not 'commas' in the output data [Menu / Advanced / Prefix / Comma outfm] set to [Use prefix].
NMEA SDDBT device	Any generic Echosounder device that can output the NMEA DBT (Depth Below Transducer) sentence. The "talker ID" must send the standard "SD" identifier (so that output lines all begin with "\$SDDBT,..". General Survey will accept the data in Feet, Meters, or Fathoms and will convert values as appropriate.
SonarMite	Any SonarMITE device. the unit will be switched into 'Engineering mode' (output format 0) and other settings may be adjusted by General Survey.

Trimble has some ESD files for other devices. To see if a definition already exists for your device, go to www.trimble.com/Survey/Trimble-Access-IS.aspx and click *Downloads* and then click *Echo Sounder Protocol Description Files*.

An ESD file for each echo sounder supported as standard is provided in the "System Files" folder. If you need to make changes to an ESD file, copy the file to a PC and rename it. Open the file in a text editor such as Notepad++. When you have finished editing the file, save your changes and then copy the file into the "System Files" folder on the controller. The name of the ESD file appears in the *Type* field in the *Echo Sounder* screen.

Note - When using an echo sounder to record depths that equal zero, you need to add the `allowZero="True"` flag immediately after the `isDepth="True"` flag. For example: `<Field name... isDepth="True" allowZero="True" />`

For more information, see [Using an Echo sounder to store depths](#).

Adding support for a different model of echo sounder

General Survey software uses XML Echosounder protocol description (*.esd) files and so may support other bathymetric echo sounders provided that their communications protocols are similar to the protocols currently supported. To do this, use one of the ESD files provided with General Survey and use it as a template. You will need to find out the format for your echo sounder and modify the ESD file accordingly.

If the format for your echo sounder is:

- delimited (such as comma or space delimited), use the SonarMite ESD file as a template.
- fixed width, use one of the CeeStar ESD files as a template.
- a NMEA string such as NMEA \$SDDBS, use the NMEA \$SDDBT ESD file as a template.

The format of the SonarMite ESD file is provided below:

```
<?xml version="1.0" encoding="UTF-8"?>
<ExternalDeviceProtocol version="1.0" >
<Device name="SonarMite in Engineering Mode" >
<MaxLatency>0.5</MaxLatency>
<Protocol type="Delimited" delimiter="20" startsWith="1" special="SonarMite" requiredFieldCount="8" >
<Field name="Depth" fieldNumber="1" type="Number" multiplier="1.0" isDepth="True" />
<Field name="Battery Voltage" fieldNumber="5" type="Number" multiplier="1.0" />
<Field name="Quality" fieldNumber="6" type="Integer" />
<Field name="Flags" fieldNumber="7" type="Integer" sonarMiteFlags="True" />
</Protocol>
</Device>
</ExternalDeviceProtocol>
```

The formats of the other ESD files are similar. Use the information below to edit the ESD file you are using as a template.

Parameter	Applicable format	Notes
Max Latency	All	MaxLatency specifies the width of the acceptable window of time that a reading can be accepted. The Maximum Latency assumes the GPS position bisects the acceptable window, therefore the echo sounder reading must be +/- MaxLatency/2 of the stored GPS position. In the example above, the MaxLatency is 0.5 and so the echo sounder reading must occur within 0.25 seconds before or after the stored GPS position. Typically, the MaxLatency is set to the period of the echo sounder measurements, but can be reduced if you prefer to reject some measurements if they arrive outside a narrower window.
Protocol		
type="Delimited" or "FixedWidth"	All	Specifies if the ESD data is output as a data string separated by an ASCII character such as a space or a comma (delimited), or if each field has a fixed number of characters (fixed width).
delimiter="2C"	delimited	Specifies the delimiter as two hex digits which specify the ASCII delimiter character (field separator). For example, space="20", comma="2C", tab="09".
lineLength=""	fixed width	Specifies the line length as a decimal number indicating the minimum length of a valid line. For example, lineLength="34".
startsWith="" startsWith2="" ignoreLines=""	All	These are optional strings to help identify valid lines of data. These can be used to specify the text that identifies the start of a line. These strings can be left blank. For these strings, any leading, trailing, and double spaces are trimmed by XML. Use underscore ("_") as a substitute for

Parameter	Applicable format	Notes
		space characters. For example, <code>startsWith="_A"</code> .
<code>special="SonarMite"</code> or <code>"NMEA"</code>	delimited, NMEA	<p>These strings specify that special treatment should apply. If you specify <code>"SonarMite"</code>, Trimble Access will send SonarMite protocol commands to the device to configure its protocol. If you specify NMEA, Trimble Access will validate the checksum on each line.</p> <p>If you are using the SonarMite ESD file as a template for another type of ESD, you should delete this string. You will also need to delete any <code>sonarMiteFlags="True"</code> strings from any fields specified <code>type="Integer"</code>.</p>
<code>requiredFieldCount=""</code>	delimited	Specifies the number of fields in a line of delimited data. For example, a typical line of SonarMite ESD data contains 8 fields: 1 0.96 0 0 0 9.3 79 0
Fields		
<code>name=""</code>	All	Specifies a name for the data in that field. You can enter anything except reserved characters.
<code>fieldNumber=""</code>	delimited, NMEA	Specifies the number of the field in the data string that contains the data for this field. Specify the <code>fieldNumber</code> as a decimal number, starting at 0. For example, <code>fieldNumber="1"</code> .
<code>start=""</code>	fixed width	Specifies the character position, starting at 0. For example, <code>start="21"</code> .
<code>end=""</code>	fixed width	Specifies the position of the first character to be excluded. The end value must be larger than the start value.
<code>type="Number"</code> or <code>"Integer"</code> or <code>"String"</code>	All	<p>Specifies the type of data in this field.</p> <p>If you are using the SonarMite ESD file as a template for another ESD, you should delete the string <code>sonarMiteFlags="True"</code> for your customized ESD file to work with your echo sounder.</p>
<code>multiplier=""</code>	All	If the type is "Number", then specify the multiplier value, which is the value to multiply the read value by to calculate the SI units. For example, <code>multiplier="0.5468"</code> to convert fathoms to meters.
<code>isDepth="True"</code> or <code>"False"</code>	All	The default value is "False". A value of "True" indicates that the <code>isDepth</code> field is to be treated as the numeric value to display and process in the application, and any other values for depths are stored without display or interpretation. This is useful when working with dual-frequency transducers such as CeeStar.
<code>allowZero="True"</code>	All	Add this flag immediately after the <code>isDepth="True"</code> flag to

Parameter	Applicable Notes format
	accept depths that equal zero.

NMEA strings for echo sounders

Echo sounders may output one of several NMEA 0183 sentences. The most common sentences are described below for reference.

NMEA DBT - Depth Below Transducer

The NMEA DBT sentence reports water depth referenced to the transducer's position. The depth value is expressed in feet, meters, and fathoms.

For example: `$xxDBT,DATA_FEET,f,DATA_METRES,M,DATA_FATHOMS,F*hh<CR><LF>`

NMEA DBS - Depth Below Surface

The NMEA DBS sentence reports water depth referenced to the surface. The depth value is expressed in feet, meters, and fathoms.

For example: `$xxDBS,DATA_FEET,f,DATA_METRES,M,DATA_FATHOMS,F*hh<CR><LF>`

NMEA outputs

To output NMEA-0183 format messages from a port on the connected GNSS receiver or from the USB-Serial port of the Geo7X/GeoXR controller, configure the settings in the *NMEA outputs* screen of your GNSS survey style.

The fields that appear in the *NMEA outputs* screen are described below.

Use job coordinates

Select the *Use job coordinates* check box if you want the selected NMEA messages to be generated by the Trimble Access software so that they use the same coordinates and APC heights as the job. If you select this check box the available NMEA message types are limited to NMEA GGA, GGK, GLL and PJK messages.

Clear this check box if you want the selected NMEA messages to be generated by the receiver so that they use the height reference available in the receiver. For orthometric heights this means the geoid model built into the receiver firmware is used, not the one used by the job. Clearing this check box makes more NMEA messages available for output.

Note – *NMEA output is always the position of the antenna phase center (APC). NMEA output during a compensated point measurement remains the APC; there is no tilt compensation applied to positions in the NMEA messages output in either receiver or job coordinates.*

Messages to output

Select the message types to output, and the rate at which each message type is output. When the *Use job coordinates* check box is selected, rates faster than 1s apply only to positions generated

during stakeout.

Serial port settings

Make sure the serial port settings match those set in the device that is receiving the NMEA messages.

Advanced settings

The *Advanced settings* group box contains configuration items that affect the format of the NMEA messages that are output.

Note – *The IEC extensions, and the setting of the GST message to GPGST rather than GLGST or GNGST at all times, are available only when using NMEA generated by the receiver firmware, where the Use job coordinates check box is not selected.*

Include IEC61162-1:2010 GNSS extensions

This setting selects which standard to use for the compliant messages. When not selected the NMEA messages comply with NMEA-0183 Standard for Interfacing Marine Electronic Devices, Version 4.0, November 1, 2008. When selected, the messages comply with the International Electrotechnical Commission (IEC) 61162-1, Edition 4 2010-11.

Max. DQI=2 in GGA

When selected, the *Quality Indicator* field in the GGA output message is never greater than 2 (DGPS). This is to support legacy systems that do not fully support the NMEA standard.

Max. age 9s in GGA

When selected, the age of differential data field in the GGA message is never greater than 9 seconds. This is to support legacy systems that do not fully support the NMEA standard.

Extended GGA/RMC

Select this check box to output high precision position data in the NMEA messages. Clear this check box to conform to the NMEA standard message length of 82 characters. If cleared, the precision of the position and height data is reduced by truncating the number of decimal places.

GP always

When selected, the NMEA talker ID is always \$GP for NMEA GST, GGA, and GLL messages regardless of the constellation(s) being tracked. For receiver firmware versions earlier than v5.10, the *GP always* setting applies only to the GST message type.

Duplicate point tolerance

In a GNSS survey, when you attempt to add a point name, the General Survey software warns you if a point of the same name already exists.

In a conventional survey, when you attempt to measure a point on face 2 that already exists as a face 1 measurement, no message appears to warn you that the point already exists.

In any type of survey, you can configure the software to warn you if you try to store a point with similar coordinates to another point already in the job. This proximity check enables you to avoid measuring points of a different name in the same location.

In a real-time GNSS survey or a conventional survey, you can set the tolerance for a duplicate point warning for points of the same name.

- In the *Same point name* group, specify the maximum distance that a new point can be from an existing point.
- A duplicate point warning appears when you try to store a new point only if it is a duplicate point outside the tolerance set.
- If the new point has the same name as an existing point, and is closer to the existing point than the tolerance specified, the point is stored as a new point, and does not overwrite the existing point.
- When you select the *Auto average* option in the survey style, the point is stored as a new point and an average of all previous positions (of the same name) is also stored.
- An averaged position has a [higher search class](#) than a normal observation.

If the new point is further from the original point than the tolerance specified, you can choose what to do with the new point when you store it. The options are:

- Discard
- Rename
- Overwrite - Overwrite and delete the original point, and all other points of the same name and the same (or lower) search class.
- Store as check - Store with a lower classification.
- Store and reorient - (This option only appears if you are observing a backsight point.) Store another observation that will provide a new orientation for subsequent points measured in the current station setup. Previous observations are not changed.
- Store another - Store the point, which can then be averaged in the office software. The original point is used in preference to this point.
- Average - Store the point and then compute and store the averaged position.

Averaging methods

Two averaging methods are supported:

- Weighted
- Unweighted

You can select the averaging method in the *Cogo settings* screen.

Note - When you select *Average*, the current observation is stored and the computed average position appears, along with the computed standard deviations for the north, east, and elevation ordinates. If there are more than two positions for the point, a *Details* softkey appears. Tap *Details* to view the residuals from the average position to each individual position. You can use the *Residuals form* to include or exclude specific positions from the average computation.

Configuring the duplicate point tolerance for points with the same name

1. From the Trimble Access menu, tap *Settings / Survey styles / <Style name>*.
2. Select *Duplicate point tolerance*.

3. Specify the horizontal and vertical tolerances. If you set these distances to zero, a warning is always given.
4. To automatically compute and store the average position, select the *Auto average* within tolerance option.

Note - When the *Auto average* option is checked, and an observation to a duplicate point is within the specified duplicate point tolerances, the observation and the computed average position (using all the available point positions) are automatically stored.

Note - The General Survey software computes an averaged coordinate by averaging the grid coordinates computed from the underlying coordinates or observations. Observations that do not allow a grid coordinate to be resolved (for example, angles only observations) are not included in the average coordinate.

For more information, see [Compute average](#).

Configuring the proximity check tolerance for points with different names

1. From the Trimble Access menu, tap *Settings / Survey styles / <Style name>*.
2. Select *Duplicate point tolerance*.
3. On page 2, select the *Proximity check* box in the *Different point name* group.
4. Specify the horizontal and vertical tolerances.

When you try to store a point that has coordinates that are within the horizontal tolerance of an observed point already in the job, then a warning message appears showing the tolerance distance and the measured horizontal distance between the two points. You can select to proceed with the measurement or cancel it.

Note – The vertical tolerance is only applied when the new observed point is within the horizontal tolerance. Use the vertical tolerance to avoid the proximity check warning when new points are measured above or below existing points but are legitimately at a different elevation, for example the top and bottom of a vertical kerb.

Note – The proximity check is only performed on observations, not on keyed in points. The proximity check is not performed in stakeout, GNSS Continuous measurement, or Calibration Point, and it is not performed in jobs with a No Projection coordinate system.

Face 1 and Face 2 observations

When you carry out two-face observations in a conventional survey during *Station setup*, *Station Setup Plus*, *Resection*, or when measuring *Rounds*, the General Survey software checks that the Face 1 and the Face 2 observations to a point are within a preset tolerance.

If the observations are out of tolerance, the *Observation: Out of tolerance* screen appears.

The screen displays the following options:

- Discard - discard the observation without storing.
- Rename - rename to a different point name.
- Overwrite - Overwrite and delete the original point, and all other points of the same name and the same (or lower) search class.
- Store as check - store with a classification of Check.
- Store another - store the observation.

Once you have completed the *Station Setup Plus*, *Resection*, or *Round* measurements, the General Survey software saves the Mean Turned Angles to each of the observed points. The software does not check for duplicate points at this stage. Therefore, to use any of the observations to compute an average position for an observed point, you must select the **Compute average** option from the *Cogo* menu.

Feature libraries

You can create a feature library by using office software and then transferring the library to the controller, or you can create a feature code list directly in the controller.

Note - Feature codes created using the General Survey software do not have attributes associated with them.

Use the following office software to create and transfer feature libraries:

To create the library, use ...	To transfer the library, use ..	File saved on controller as...
Feature and Attribute Editor	Trimble Geomatics Office	.fal
Feature Definition Manager	Trimble Business Center	.fxl

Notes

- *Trimble Business Center version 1.0 Feature Definition Manager creates and reads version 1 FXL files.*
- *Trimble Business Center version 2.0 Feature Definition Manager creates and reads version 1 and 2 FXL files.*
- *Trimble Business Center version 2.1 Feature Definition Manager creates and reads version 1, 2 and 3 FXL files.*
- *General Survey does not upgrade a FXL v2 file to a FXL v3 file.*
- *General Survey version 1.90 and later can read version 1, 2 and 3 FXL files, but only create a version 3 file.*
- *General Survey versions 1.00 through to 1.80 can read FXL version 1 and version 2 files, but can only create a version 2 file.*
- *General Survey versions 1.00 and later can read FAL files*
- *Trimble Survey Controller version 11.40 and earlier created FAL files.*
- *Trimble Survey Controller versions 12.00 through to 12.22 creates and reads FXL version 1 files. They do not support version 2 or 3 files.*

There are up to five fields to configure when adding or editing feature codes. The options available depend on the type of file:

- All feature libraries have a *Feature code* and *Description*.
- All feature libraries have a *Feature type*. You can edit the *Feature type* in a FAL file, and you can set the *Feature type* when you create a new FXL file, but you cannot edit the *Feature type* in a FXL file once it has been set.
- All feature libraries have a *Line style*. There are only two line styles supported by the General Survey software, *Solid lines* and *Dashed lines*.

- Only .fxl feature libraries can have a *Line color*.
- Only version 3 fxl feature libraries can have a polygon feature type.

Creating a new feature code list

1. From the Trimble Access menu, tap *Settings / Feature Libraries*.
2. Tap *New*.
3. Enter the name of the list.
4. Tap the name of the new feature library file you just created and then tap *Edit* to add, delete, or edit codes.

Note - An individual feature code cannot contain more than 20 characters. But the maximum number of characters in a code field is 60.

Tip - The *Code* and *Description* are both displayed when you use feature libraries. Most recently used codes are displayed indented at the top of the list.

Feature code names that contain spaces appear in the General Survey software with a small dot between the words, for example, Fire·Hydrant. These dots do not appear in the office software.

Some symbols are not supported in feature libraries, for example ! and []. If you use unsupported symbols when creating a library in the office software, the General Survey software converts them to the underscore symbol "_" when they are transferred.

Line codes

When it is operating with a feature code library, the General Survey software can process the feature codes so that points with their *Feature type* set to *Line* or *Polygon* will be joined by lines. Polygons are automatically closed.

To configure a feature library for real time feature code processing:

1. From the Trimble Access menu, tap *Settings / Feature Libraries*.
2. Select the feature library and then tap *Edit*.
3. Select the feature code and then tap *Edit*, or tap *Add* to create a new feature code.
4. Make sure the *Feature type* is set to *Line* or *Polygon*.
5. Select a *Line color* for the line.
6. Tap *Accept* and then tap *Store* to save the changes.

If the [CAD linework filter](#) is turned on in the map, the General Survey software draws lines between points, based on the specified display properties.

Notes

- There are 15 basic colors available when configuring the line color in the General Survey software.
- Colors can be defined in the office using the Feature Manager software and transferred via an FXL file to the controller. The colors defined in the .fxl file by the Feature Manager software may not be identical to the colors used by the General Survey software.

- Colors can be defined in the Feature Manager as 'By layer' or 'Custom'.
 - When 'By layer' has been defined the General Survey software uses black.
 - When 'Custom' has been defined the General Survey software uses the closest color match to the General Survey palette.
 - You cannot define the color as 'By layer' or 'Custom' in the General Survey software. If set in the office software, these options are displayed in the General Survey software, and can be changed to a General Survey software color, but if this is done you cannot change them back.
- General Survey does not fill feature coded polygons.

Control codes

With line codes set up in a feature library (as described above), points that have the same code can be joined by lines.

Example - To survey the center line of a road, create a center line (CL) feature code as a *Line* feature type and assign the code CL to each measured point. If you have the [CAD linework filter](#) turned on, all points to which the code CL has been assigned are joined.

However, you will need extra line joining control to start new line sequences, close figures, and join specific points. To achieve this extra control, define *control codes*.

Note – When surveying a point that uses a control code you must assign a line code and then the control code. A control code always follows the line code it applies to and is separated from the Line code by a space character.

To create a *control code*, set the *Feature type* for a code you are editing to *Control code*. When you have done this, a new *Control code action* is available.

Example - To survey the center line of a road that has gaps, in addition to the center line (CL) feature code, create a start join (Start) feature code as a control code feature type and an end join (End) feature code as a control code feature type. To each measured point assign the code CL. To the point that defines the end of the center line sequence (that is, the start of the gap), select the CL feature code, insert a space and then select the End feature code. To the point that restarts the center line, select the CL feature code, insert a space and then select the Start feature code.

The following control code actions can be used with line codes:

Control code	Action
Join to first (same code)	Enter this control code to join the point to the first point in the sequence that has the same code. For example, <code><Line code> <Join to first (same code)></code> . Whether the current point will also join to the next point that has the same code depends on the control code entered for the next point.
Join to named point	Enter this control code to join the current point to the point named after this control code in the code field. The control code and name should be separated by a space. For example, <code><Line code> <Join to named point> 123</code> . Whether the current point will also join to the next point that has the same code depends on the control code entered for the next point.
Start join	Enter this control code to start a new join sequence. The current point is set as the

Control code	Action
sequence	first point in the sequence.
End join sequence	Enter this control code to instruct the system that the current point is the last point in the join sequence. This means that the next point that has the same line code will not join to it.
Skip join	Operates in a similar fashion to the <i>Start join sequence</i> action, but it only stops the join action of the line code it is associated with. It does not make the current point the first point in a new join sequence. <i>Skip join</i> is ignored for polygons.
Start tangential arc	Enter the <i>Start tangential arc</i> control code to start an arc tangentially. The azimuth between the previous point with the same feature code, and the point that has the start arc control code, defines the entry tangent direction.
End tangential arc	Enter the <i>End tangential arc</i> control code to end an arc tangentially. The azimuth between the point with the end arc control code, and the next point with the same feature code, defines the exit tangent direction.
Start non-tangential arc	Enter the <i>Start non-tangential arc</i> control code to start an arc non-tangentially. You do not need a previous point with the same feature code to start an arc this way.
End non-tangential arc	Enter the <i>End non-tangential arc</i> control code to end an arc non-tangentially. No next point with the same feature code is required to end an arc this way.
Start smooth curve	Enter the <i>Start smooth curve</i> control code to start a smooth looking curve. Subsequent points are added to the smooth curve until you use the <i>End smooth curve</i> control code. If any point that makes up the curve has a null elevation then the entire curve is considered to be 2D, and will lie on the ground plane.
End smooth curve	Enter the <i>End smooth curve</i> control code to end a smooth curve. The next point is not added to the curve.
Start rectangle	Enter the <i>Start rectangle</i> control code to define a rectangle. Referring to the following diagrams, the rectangle can be defined by: <ul style="list-style-type: none"> • Two points where the first point (1), defining one corner of the rectangle, uses the <i>Start rectangle</i> control code, the second point (2) defines the next corner of the rectangle and one of the two points includes a width value (3). For example, <i><Line code> <Start rectangle> 8</i> for the first point and then <i><Line code></i> for the second point. When given a positive width value, the rectangle is drawn to the right of the line drawn from the first point to the second point. If the width value is negative, the rectangle is drawn to the left. • Three points where the first point (4), defining one corner of the rectangle, uses the <i>Start rectangle</i> control code, the second point (5) defines the next corner of the rectangle and the third point (6) is used to define the width. For example, <i><Line code> <Start rectangle></i> for the first point, <i><Line code></i> for the second point and then <i><Line code></i> for the third point.

Control code	Action
--------------	--------

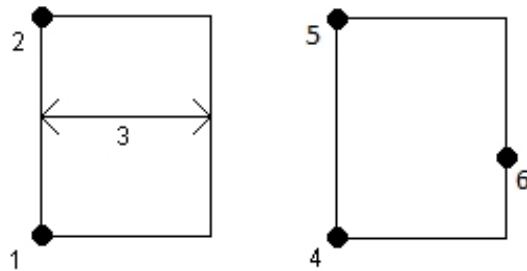

Note - Rectangles are drawn respecting the elevation of all points.

Start circle (center) Enter the *Start circle (center)* control code to define a circle. Referring to the following diagrams, the circle can be defined by:

- One point (1) at the center of the circle where that point uses the *Start circle (center)* control code followed by a radius value (2). For example, `<Line code> <Start circle (center)> 8.`
- One point (3) at the center of the circle where that point uses the *Start circle (center)* control code and a second point (4), which lies on the edge of the circle, and is used to define the radius of the circle. For example, `<Line code> <Start circle (center)>` for the first point and then `<Line code>` for the second point.

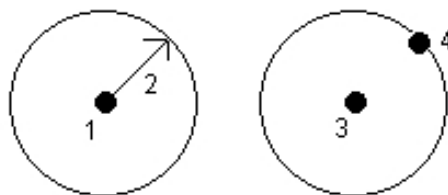

Start circle (edge) Enter the *Start circle (edge)* control code to define a circle. The circle is defined by three points that lie on the edge of the circle. The first point uses the line code and the *Start circle (edge)* control code, and the second and third points just use the line code.

Horizontal offset Enter the horizontal offset and vertical offset control codes to offset feature coded lines and arcs by a horizontal or vertical value.

These codes are ideal when surveying a curb and gutter where points would be measured at the flow line (invert) of the gutter with a line code and horizontal and vertical offset control codes. For example, `<Line code> <Horizontal offset> 0.3 <Vertical offset> 0.04.`

Refer to the following real world example of a curb and gutter where FL is the line code for the flow line, H is the horizontal offset control code and V is the vertical offset control code:

Control code	Action
--------------	--------

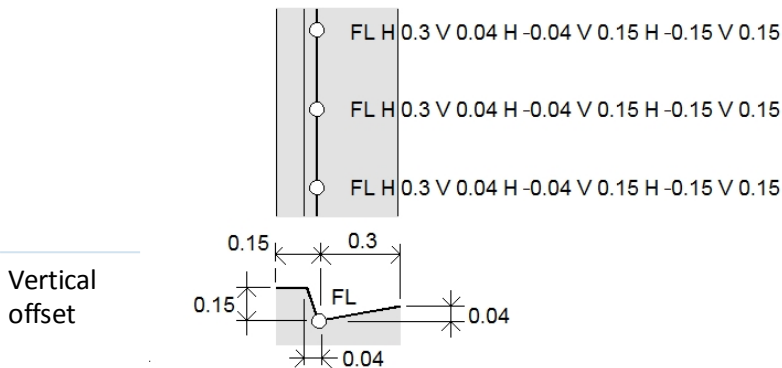
**Notes**

- To break an offset use H - as the code.
- A negative horizontal offset value creates an offset to the left of the line. A negative vertical offset value creates an offset below the line.
- You cannot offset line work created using the smooth curve control codes.

Notes

- New FXL libraries created on the controller support all control codes. If you are using an old FXL file, then the control codes supported depend on the FXL file version.
 - Smooth curve control codes need FXL file v4 or later.
 - Rectangle and circle control codes need FXL file v5 or later.
 - Horizontal and vertical offset control codes need FXL file v6 or later.

To upgrade older version files use the File / Save As option in the Feature Definition Manager and select the latest Save As format.

- When processing the arc feature codes and if an arc cannot be computed, the segment is drawn as a dashed red line to indicate that something is wrong with the coding. Situations where this will occur are:
 - An arc is defined by two points and no tangency information is defined for at least one of the two points.
 - A two point arc is defined as being tangential at both the start and end but these tangents do not work.
 - A best fit arc from three or more points cannot be determined, for example when the points are all on a straight line.
- Circles are drawn horizontal at the elevation of the first point with an elevation.

Configuring a radio data link

The General Survey software provides a **Real-Time Kinematic** survey style. Real-time kinematic surveys use a [data link](#) to send observations or corrections from the base station to the rover. The

rover then calculates its position in real time.

Configuring the data link as a radio connection

1. Connect the controller, receiver, power, and radio. For more information, see [Base receiver setup](#).

Alternatively, use a Y-cable to connect the power and the controller directly to the radio.

2. From the Trimble Access menu, tap *Settings / Survey styles / <Style name>* and then tap *Edit*.
3. Select *Base data link* or *Rover data link* depending on which radio you are configuring.
4. Set the *Type* field to Radio.
5. Set the *Radio* field to the radio type you are using.

If your radio does not appear on the list, select *Custom radio* and then define the receiver port, baud rate, and parity.

6. If the radio link being used has a known maximum data throughput rate, select the *Bandwidth limiting* check box and then enter the known maximum data value in bytes per second into the *Bandwidth limit* field.

The GNSS base receiver uses this value to logically reduce the number of satellite messages so that the maximum rate is not exceeded. This option is available for CMR+, CMRx, and RTCM v3.x broadcast formats.

If you have an old radio or run at low baud rates and if you're not getting all the base SVs, try lowering the bandwidth limit until you do.

7. If the radio is connected:
 - directly to the receiver, clear the *Route through controller* check box. Specify the receiver port number that the radio is connected to, and the baud rate for communications.
 - to the controller, select the *Route through controller* check box. This enables real-time data between the receiver and the radio to pass through the controller. Specify the controller port number that the radio is connected to, and the baud rate for communications.

Notes

- To connect to and configure the internal settings of the radio you have selected, tap *Connect*.
 - Some TRIMTALK and Pacific Crest radios must be in command mode before they can be configured. Command mode happens momentarily at power up. Follow the prompts to connect to the radio.
 - If the *Connect* softkey is not displayed, you cannot configure the internal settings for the type of radio you have selected.
 - To add a new receive frequency for the rover radio, tap *Add Frq*. Enter the new frequency and tap *Add*. The new frequency is sent to the radio and appears in the list of available frequencies. To use the new frequency, you must select the frequency from the list.
8. If the details are correct, tap *Enter*.

A radio signals icon appears in the status bar when a survey is started. If there is a problem with the data link between the base and rover receivers, a red cross is drawn over the radio signals icon.

Tap on the radio signals icon to check the settings. If the controller is connected to a receiver with an internal radio you can also reconfigure the radio's internal settings.

Tip - You can also access the data link configuration by tapping the *Data link* button in [GNSS functions](#).

Note - *In some countries it is illegal to change the frequency of a radio. The General Survey software uses the latest GNSS position to see if you are in one of these countries. If you are, only the available frequencies are displayed in the Frequency field.*

If you select *Base data link* and set the *Type* field to *Custom radio*, you can also enable *Clear To Send (CTS)*.

WARNING - Do not enable CTS unless the receiver is connected to a radio that supports CTS.

The Trimble R / 5000 series GNSS receivers support RTS/CTS flow control when you enable CTS.

For more information on CTS support, refer to the documentation supplied with your receiver.

Note - *The internal radio in a Trimble integrated GNSS receiver can also operate as a base radio if it is configured as a transceiver, and if the UHF Transmit option is on in the receiver. This avoids having to use an external radio solution at the base receiver to broadcast base data.*

Radio considerations

Real-time survey methods rely on trouble-free radio transmission.

To reduce the effects of interference from other base stations operating on the same frequency, use a transmission delay for your base station that does not coincide with others on the same frequency. For more information, see [Operating several base stations on one radio frequency](#).

Sometimes the conditions or topography of a site adversely affect radio transmission, resulting in limited coverage.

To increase site coverage:

- Move the base stations to prominent points around the site.
- Erect the base radio antenna as high as possible.
- Use radio repeaters.

Tip - Double the height of the broadcast antenna to increase the coverage by approximately 40%. To achieve the same effect, it would be necessary to quadruple the radio broadcast power.

Radio repeaters

Radio repeaters increase the broadcast range of a base radio by receiving the base transmission and then rebroadcasting it on the same frequency.

You can use one repeater with a radio that has a 12.5 kHz channel spacing, and one or two repeaters with a radio that has a 25 kHz channel spacing. For details of the Trimble and Pacific Crest radios, please refer to the specific product documentation.

You can configure the Trimble R series internal radio to repeat base data to other rovers while performing a rover survey. This is known as a roving repeater setup. The internal radio can repeat the base signal over its UHF communication link to other rovers while simultaneously performing a

rover survey. This option is available in Trimble GNSS receivers with internal radios that have the UHF Transmit option enabled. Select this repeater mode when you connect to the internal radio from the *Rover data link* screen in the Survey Style.

Note - To use any of these radios as repeaters, they must be configured as repeaters. To do this, follow the steps above to connect to the radio and then choose a repeater mode, which appears if the radio you are connected to supports being a repeater. Alternatively, if the radio has a front panel, use that to set the repeater mode.

Cellular modem – Overview

In a real-time survey, you can use an external modem or Trimble internal modem as the corrections data link between the base and the rover receivers, and to connect to the Internet to exchange data and email.

You can use a cellular modem at both the base and rover receivers. At the base, the cellular modem is connected to the receiver. At the rover, the cellular modem can be connected to the receiver or the controller.

Notes

- Cellular modems used with the General Survey software must support Hayes compatible AT commands.
- Base receivers used with modems must support CTS flow control.

You can use a cellular modem in dial-in mode to receive base data from a service provider that uses a dial-in modem as the service data link, or from a base station equipped with a modem configured to answer dial-in data calls. When you use your own base station, the rover cellular modem dials directly to the base cellular modem. The cellular modem can be connected to the receiver or to the controller.

To use an external modem or Trimble internal modem in an RTK survey, configure the base and rover data link as a [dial-in connection](#) when you create or edit a survey style.

To perform an RTK survey using an Internal data link, use one of the following methods:

- Receive base data from a service provider, using a system such as Trimble VRS Now™, GPSNet or GPSBase.
- Use your own remote base station that is also connected to the Internet by an external modem or Trimble internal modem. If you use the external modem method, you must have a General Survey data collector connected at all times at the base.

If you use your own base station connected to the Internet, you can set up the base station to operate as a server that the rover will connect to, or to transfer the data to a distribution server. When the base operates as a server, the number of rover connections to that base is limited by the capacity of the base Internet connection. In some cases, only one rover connection may be possible. When the base transfers data to a distribution server, the distribution server can send the base data to many rovers.

To use an external modem or Trimble internal modem to connect the controller to the Internet, see [Connecting to the Internet](#). Configure the base and rover data link as an [Internet connection](#) when you create or edit a survey style. The modem must support an Internet connection.

Configuring an Internet data link

The General Survey software provides a **Real-Time Kinematic** survey style. Real-time kinematic surveys use a [data link](#) to send observations or corrections from the base station to the rover. The rover then calculates its position in real time.

To configure the data link as an Internet connection:

1. From the Trimble Access menu, tap *Settings / Survey styles / <Style name>* and then tap *Edit*.
2. Select *Base data link* or *Rover data link* depending on which radio you are configuring.
3. Set the *Type* field to Internet connection.
4. From the *GNSS contact* field, tap the field menu (right arrow) button to access the [GNSS contacts](#) form. Select a GNSS contact from the list or create a new contact.

You can also enter the GNSS contact name for a contact that you have already configured.

Note - The GNSS Contact list is filtered according to the modem type.

5. To display the GNSS contact that is configured in the survey style, or change the GNSS contact when you start the survey, select the *Prompt for GNSS contact* check box.

Note - To use the Trimble receiver internal GSM/mobile Internet module for a rover RTK survey, use Bluetooth technology to connect the controller to the receiver. For an RTK base survey, you can use Bluetooth technology if you are using Route through controller in the GNSS contact.

When you start a survey using a Trimble internal modem, General Survey software connects to the mountpoint and then begins the survey. For more information, see [Starting a real-time survey using a mobile Internet connection](#).

Note - You can also create and edit profiles by editing the *[GNSSContacts.xml]* file that is stored in the *[System files]* folder. To do this, copy the file to your computer, edit the file and then load it back into the *[System files]* folder.

Before you start a survey using a Trimble internal modem:

1. Connect the controller to the Trimble GNSS receiver that has an internal modem and Bluetooth wireless technology.
2. From the Trimble Access menu, tap *Settings / Connect / Bluetooth*. In the *Connect to GNSS rover* field, select the receiver.

Tip - Tap the auto-connect icon before a connection is made, or tap the receiver icon after a connection is made, to access a shortcut to the Bluetooth configuration screen.

Configuring a dial-in data link

The General Survey software provides a **Real-Time Kinematic** survey style. Real-time kinematic surveys use a [data link](#) to send observations or corrections from the base station to the rover. The rover then calculates its position in real time.

To configure the data link as a dial-in connection:

1. From the Trimble Access menu, tap *Settings / Survey styles / <Style name>* and then tap *Edit*.
2. Select *Base data link* or *Rover data link* depending on which radio you are configuring.

3. Set the *Type* field to Dial-in.
4. In a dial-in rover survey, if you are connecting the cellular modem directly to the controller using a cable or Bluetooth, select the *Route through controller* check box.
5. From the *GNSS contact* field, tap the field menu (right arrow) button to access the *GNSS contacts* form. Select a GNSS contact from the list or create a new contact.

You can also enter the GNSS contact name for a contact that you have already configured.

Note - The GNSS Contact list is filtered according to the modem type.

6. To display the GNSS contact that is configured in the survey style, or change the GNSS contact when you start the survey, select the *Prompt for GNSS contact* check box.

Note - To use the Trimble internal modem for a rover survey, use Bluetooth technology to connect the controller to the receiver. For base surveys, you can use Bluetooth technology if you are using Route through controller in the GNSS contact.

When you start the survey using the Trimble internal modem, the General Survey software dials the base station's modem and then begins the survey. For more information, see [Starting a real-time survey using a dial-in connection](#).

Note - You can also create and edit profiles by editing the *[GNSSContacts.xml]* file that is stored in the *[System files]* folder. To do this, copy the file to your computer, edit the file and then load it back into the *[System files]* folder.

Before you start a survey using a Trimble internal modem:

1. Connect the controller to the Trimble GNSS receiver that has a Trimble internal modem and Bluetooth wireless technology.
2. From the Trimble Access menu, tap *Settings / Connect / Bluetooth*. In the *Connect to GNSS rover* field, select the receiver.

Tip - Tap the auto-connect icon before a connection is made, or tap the receiver icon after a connection is made, to access a shortcut to the Bluetooth configuration screen.

GNSS contacts

If you use a cellular modem as the corrections data link for a real-time survey, you can create and configure the Internet or dial-in connection.

To add, edit, or delete entries in GNSS contacts, tap *Settings / Connect / GNSS contacts* from the Trimble Access menu.

Setting up a Bluetooth connection for an external cellular modem dial-in or mobile Internet connection

Before you start a survey using a cellular modem connected to the controller with Bluetooth, make sure that the phone is paired with the controller.

Bluetooth pairing must establish that both the controller and the modem have permission to communicate with each other.

To start the pairing process with a Bluetooth modem:

1. Make sure that the phone is turned on and that it is in *discoverable* mode.
2. From the Trimble Access menu, tap *Settings / Connect / Bluetooth* and then tap *Config* to bring up the Bluetooth configuration screen for the controller.

Tip - Tap the auto-connect icon before a connection is made, or tap the receiver icon after a connection is made, to access a shortcut to the Bluetooth configuration screen.

Note - If you are using a Trimble GNSS receiver with an Internal modem, you do not need to scan for the modem separately from the receiver. The Trimble GNSS receiver and the internal modem are recognized by a Bluetooth scan as being the same device but with serial port and dial-up networking capabilities.

Creating and configuring cellular modem GNSS contacts

1. From the Trimble Access menu, tap *Settings / Connect / GNSS contacts*.
2. Tap *New* or select a GNSS contact to configure.
3. Enter the contact *Name*.
4. Select a *Contact type*.
 - If you are configuring the contact type of a rover that is obtaining corrections from the Internet, select *Internet rover*.
 - If you are configuring the contact type of a rover that will dial in to a modem to obtain corrections, select *Dial-in rover*.
 - If you are configuring the contact type of a base that is sending corrections to the Internet, select *Internet base*.
 - If you are configuring the contact type of a base that you will dial in to, using a modem to obtain corrections, select *Dial-in base*.

Deleting a GNSS contact

1. From the Trimble Access menu, tap *Settings / Connect / GNSS contacts*.
2. Highlight the entry that is to be deleted.
3. Tap *Delete*.
4. When asked if you want to permanently delete the contact, tap *Yes*.

Creating a GNSS contact for a dial-in data link

1. From the Trimble Access menu, tap *Settings / Connect / GNSS contacts*.
2. Tap *New* or select a GNSS contact to configure.
3. Enter the contact *Name*.
4. If required, select a *Contact type*. If you are configuring the profile of a:
 - rover that will dial in to a modem to obtain corrections, select *Dial-in rover*.
 - base that you will dial in to using a modem to obtain corrections, select *Dial-in base*.

5. Enter all of the GNSS contact details.
6. Tap *Store*.

The following table shows cellular modem commands and information that may be useful when completing a new *GNSS contact*.

Field	Information required	Functions of command
Modem PIN (optional)	Number (4-8 digits).	Unlocks the cellular modem.
Init string (optional)	Command Note - For the base modem, the command must leave the modem in auto-answer mode. Alternatively, set the auto-answer mode separately, using a Terminal program.	Starts communication and sets up modem options.
Hang up	Command	Ends communication.
Dial prefix	Command	Command used to initiate dialing number.
Number to dial	Phone number of the base station modem. Note - Use a comma (,) to send a short delay, for example, to separate the area code from the number.	-
Dial suffix (optional)	Command Note - The Dial prefix, Number to dial, and Dial suffix values are concatenated to send to the modem.	Software sends to the modem after it has dialed the number.
Post connect (optional)	Once the connection is established between the base and rover modems, information is sent from the rover to the base. This is usually the log-in name and password. Note - Use a caret (^) to send a carriage return and a 3-second delay to the base system. For example, use this to separate a log-in name from a password.	-

When you start a survey using the Trimble Internal modem, General Survey software dials the base station's modem and then begins the survey. For more information, see [Starting a real-time survey using a dial-in connection](#).

For information on starting a real-time survey using a cellular modem, see:

[Base receiver setup](#)

[Starting a real-time survey using a dial-in connection](#)

[Wide-area RTK surveys](#)

Creating a GNSS contact for an Internet data link

In an RTK survey, you can use an external modem or Trimble internal modem as the data link between the base and the rover receivers, and to connect to the Internet to exchange data and email.

Configuring a new GNSS contact for a rover survey

To configure a new GNSS contact to use an external or Trimble internal Internet connection for a rover survey:

1. From the Trimble Access menu, tap *Settings / Connect / GNSS contacts*.
2. Tap *New* or select a GNSS contact to configure.
3. Enter the contact *Name*.
4. If required, set the *Contact type* to Internet rover.
5. In the *Network connection* field, key in a network connection or select one from the pop-up directory. To create a network connection for a:
 - TSC3 / TSC2 / TCU / Slate / Geo7X / GeoXR controller, tap *Config*. See "To create or edit an Internet connection using a phone/modem for a Trimble non-tablet controller" in [Connecting to the Internet](#).
 - Trimble tablet, tap *Add*. See "To create a new network connection on the Trimble tablet" in [Connecting to the Internet](#).
6. If required, enter the *Modem PIN*.

The modem PIN may be required to unlock the cellular modem.

7. Specify an Access Point Name (APN) for the modem.

To select a preset APN, tap the field menu (right arrow) button and select *Select Access Point Name (APN)* to select a *Location* and *Provider and plan*.

Note - You can also create and edit a preset APN list by editing the *[ServiceProviders.xml]* file that is stored in the *[System files]* folder. To do this, copy the file to your computer, edit the file and then load it back into the *[System files]* folder.

The APN is provided by your internet service provider when you set up an account.

8. On a Trimble CU, if your mobile Internet provider requires a user name and password for a network connection, select the *Show 'Connect' dialogue* check box in your GNSS contacts list. The system prompts you to enter a user name and password before it establishes a network connection.

Note - The operating system on other non-tablet controllers does not support the *Show 'Connect' dialogue* check box. This is because you can now specify a username and password when you create the network connection. These settings are saved on the controller so that you do not need to enter them each time you connect.

9. If the rover is to connect to the Trimble CenterPoint RTX correction service using an Internet connection, select the *Use RTX (Internet)* check box. When this check box is selected the *Mountpoint name* field appears. Select the mountpoint appropriate for your RTX subscription and region. The *RTXIP* mountpoint is for global RTX corrections, while others are particular to

specific network coverage areas.

If required, select the *Use proxy server* check box and enter the proxy server address and port. Then go to step 18.

Otherwise go to step 11.

10. If the rover is to connect to the base through **NTRIP**, select the *Use NTRIP* check box. Otherwise go to step 14.
11. If the rover is to connect to the proxy server, select the *Use proxy server* check box and then enter the proxy server address and port. The proxy server check box appears when you select the NTRIP check box.
Obtain the proxy server address and port from the Internet service provider.
12. To connect to a Mountpoint on starting a survey, without being prompted for the Mountpoint name, select *Connect directly to Mountpoint* and enter a *Mountpoint name*.
If a Mountpoint name is not specified, the system will prompt you when you start a survey. Your selection will then be stored in GNSS contacts. If the specified mountpoint cannot be accessed when you start the survey, a list with available Mountpoints appears.
13. If required, enter an *NTRIP username* and *NTRIP password*.
14. If you are configuring a rover connection, enter the *IP Address* and *IP Port* number of the server you are connecting to as a source for base data into the *Edit GNSS contact* form.
Obtain the IP address of the base from the Internet GNSS correction data provider, or, if you are using a controller at the Internet base, use the IP Address and IP port values displayed in the *IP Settings of this base* field on the *Base* screen displayed on the controller at the base.
Note - *If the IP address of the base controller appears to be invalid, Trimble recommends that you perform a soft reset of the device before you connect to the Internet and start the base.*
15. In the *Connection type* field select the method your modem uses to connect to the Internet:
 - If your modem uses mobile Internet, select *Mobile internet*.
 - If your device is a CDPD modem, select *CDPD*.
 - If you are using a dial-up Internet connection where a phone number is used to dial your ISP, then select *Dial-up*.
16. If the rover must supply identification information through regular NMEA messages to the base data server, select the *Send user identity info* check box. At the start of the survey, the software asks you to enter this information.
17. Tap *Store*.

When you start the survey, the General Survey software establishes a network connection with the external modem or Trimble internal modem and then begins the survey. For more information, see [Starting a real-time survey using a mobile Internet connection](#).

Configuring a new GNSS contact to use an Internet connection for a base survey

1. From the Trimble Access menu, tap *Settings / Connect / GNSS contacts*.
2. Tap *New* or select a GNSS contact to configure.
3. Enter the contact *Name*.
4. If required, set the *Contact type* to Internet base.

5. If you want the controller connected to the internet at the base, which requires leaving the controller connected to the base receiver while the base survey is running, select the *Route through controller* check box.

If you clear the *Route through controller* check box, the base receiver uploads base data to a server, and the controller does not need to remain connected to the base receiver after the base survey is started. This requires receiver firmware version 3.70 or later.

If you are not using *Route through controller*, go to step 11.

6. In the *Network connection* field, key in a network connection or select one from the pop-up directory. To create a network connection for a:
 - TSC3 / TSC2 / TCU / Slate / Geo7X / GeoXR controller, tap *Config*. See "To create or edit an Internet connection using a phone/modem for a Trimble non-tablet controller" in [Connecting to the Internet](#).
 - Trimble tablet, tap *Add*. See "To create a new network connection on the Trimble tablet" in [Connecting to the Internet](#).
7. If required, enter the *Modem PIN*.

The modem PIN may be required to unlock the cellular modem.

8. Specify an Access Point Name (APN) for the external modem.

To select a preset APN, tap the field menu (right arrow) button and select *Select Access Point Name (APN)* to select a *Location* and *Provider and plan*.

Note - You can also create and edit a preset APN list by editing the *[ServiceProviders.xml]* file that is stored in the *[System files]* folder. To do this, copy the file to your computer, edit the file and then load it back into the *[System files]* folder.

The APN is provided by your internet service provider when you set up an account.

9. On a Trimble CU, if your mobile Internet provider requires a user name and password for a network connection, select the *Show 'Connect' dialogue* check box in your GNSS contacts. The system prompts you to enter a user name and password before it establishes a network connection.

Note - The operating system on other non-tablet controllers does not support the *Show 'Connect' dialogue* check box. This is because you can now specify a username and password when you create the network connection. These settings are saved on the controller so that you do not need to enter them each time you connect.

10. Set the *Base operation mode* to *Upload data to remote server* when the data should be uploaded to a server, or to *Operate as a server*.
11. If uploading data to a remote **NTRIP** server, select the *Use NTRIP* check box.
 - Specify a *Mountpoint name*.
 - If required, enter the *NTRIP username* and *NTRIP password*.
12. Do one of the following:
 - If you are configuring your GNSS contacts to *Operate as a server*, enter the *IP Port*.
The IP Address and IP port values will be displayed in the *IP Settings of this base* field on the *Base* screen displayed on the controller at the base once the base is started.

- If you are configuring a base connection to upload to a remote server, enter the *IP Address* and *IP Port* of the remote server.

Note - If the IP address of the base controller appears to be invalid, Trimble recommends that you perform a soft reset of the device before you connect to the Internet and start the base.

Tip - To connect a rover to the base, you must start a mobile Internet base with a public IP address.

13. In the *Connection type* field select the method your modem uses to connect to the Internet:
 - If your modem uses mobile Internet, select *Mobile internet*.
 - If your device is a CDPD modem, select *CDPD*.
 - If you are using a dial-up Internet connection where a phone number is used to dial your ISP, then select *Dial-up*.

14. Tap *Store*.

When you start the survey, the General Survey software establishes a network connection with the external modem or Trimble internal modem and then begins the survey. For more information, see [Starting a real-time survey using a mobile Internet connection](#).

Note - If the IP address of the base controller appears to be invalid, Trimble recommends that you perform a soft reset of the device before you connect to the Internet and start the base.

Testing a mobile Internet configuration in GNSS contacts

When there are connection problems or if the GNSS contacts contains incorrect settings, use the *Test* softkey to troubleshoot:

1. From the Trimble Access menu, tap *Settings / Connect / GNSS contacts*.
2. Highlight the GNSS contact entry that you want to test.
3. Tap *Edit* and then tap *Test*.
4. General Survey steps through the connection process using the settings defined in the *GNSS contacts* file and tests the settings to make sure that they are correct. If the test fails Bluetooth or modem connection settings, or if the APN activation does not succeed, a report is generated detailing the problem and suggesting a solution.

Note - Only mobile Internet GNSS contacts can be tested.

Connecting to the Internet using a GNSS contact

1. From the Trimble Access menu, tap *Settings / Connect / GNSS contacts*.
2. Highlight a GNSS contact that is configured for an Internet connection.
3. Tap the *Connect* button at the bottom of the *GNSS contacts* form. An Internet connection is established and a check mark appears next to the contact to show that it is in use.
4. To end the Internet connection, highlight the GNSS contact and then tap *Hang up*.

If you start a survey that uses a mobile Internet data link after you establish an Internet connection in *GNSS contacts*, then the General Survey software uses the already established connection for the survey.

Note - The Access Point Name (APN) that you enter provides network routing and connection information for the service being requested. You can obtain this information from your mobile Internet service provider.

Note - If you are using the Receiver Internal modem for an Internet connection and you are connected to the receiver through Bluetooth wireless technology, you must select the receiver in the Bluetooth modem field of the Edit GNSS contacts form.

Networked Transport of RTCM via Internet Protocol (NTRIP)

NTRIP uses the Internet to distribute real-time GNSS base station data.

When GNSS contacts is correctly configured and you start the survey, a connection is established to the NTRIP server. In addition, a table appears showing the available sources of corrections from the server. These can be single station sources, or network sources (for example, VRS). The type of base station data that this "mount point" provides is shown in the source table. Select the source that you want to use. When you do this, a connection is made to that source, and base station data begins to stream through General Survey to the connected GNSS receiver.

Note - To determine the closest source, tap the Distance from here heading to sort that column.

If authentication is required to connect to a particular mount point, and this was not configured in GNSS contacts, the General Survey software displays a screen where you can enter your user name and password.

When the General Survey software connects to the NTRIP caster, it checks if the caster supports NTRIP version 2.0.

- If the caster acknowledges that it supports version 2.0, the General Survey software communicates using version 2.0 protocols.
- If the caster does not support version 2.0, the General Survey automatically uses NTRIP version 1.0.

To force the General Survey software to always use NTRIP version 1.0, select the *Use NTRIP v1.0* check box when you configure the NTRIP settings.

NTRIP version 2 includes improvements to the original standard. The General Survey software now supports the following NTRIP version 2 features:

NTRIP 2.0 feature	Advantages over 1.0
Full HTTP compatibility	Addresses proxy server issues. Supports virtual hosts using the "Host directive".
Chunked transfer encoding	Reduces data processing time. More robust data checking.

Connecting to the Internet

Internet connection settings are managed in *Internet Setup*. To get to the *Internet Setup* screen in Trimble Access, do one of the following:

- From the Trimble Access menu, tap *Internet Setup*.
- Tap *Settings / Connect / Internet Setup*.

- Tap the Internet Connection button ( or ) from the Trimble Access task bar.

The steps required to connect to the Internet depend on the controller you are using. For more information, see the sections below:

- Connecting to the Internet on a [Trimble non-tablet controller](#)
- Connecting to the Internet on a [Trimble tablet](#)

Connecting to the Internet on a Trimble non-tablet controller

To connect to the Internet on a TSC3 / Slate / Geo7X / GeoXR, [create an Internet connection](#) using the controller's internal modem.

The Trimble CU and TSC2 controllers do not have an internal cellular modem so you must use an external phone or modem to connect to the Internet. Before you start, do one of the following:

- If you are using a cable, connect the cellular modem data cable to the serial port on the controller.
- If you are using Bluetooth wireless technology, make sure that Bluetooth is enabled, and that the cellular modem is paired and connected.

Once you are connected to the phone or modem, [create an Internet connection](#) as you would if you were using a controller with an internal modem.

Alternatively, if you are using a TSC3 / TSC2 / Geo7X / GeoXR controller you can [connect to the Internet using the internal Wi-Fi radio](#).

To activate a Trimble non-tablet controller on a CDMA network:

If you are using a Geo7X, or a TSC3 controller with an integrated dual-mode modem in the United States and have the appropriate subscription, you can use it to access the Verizon CDMA network. The dual mode modem can run in GSM/GPRS mode or CDMA mode.

All Geo7X controllers have a dual-mode modem. TSC3 controllers with a dual-mode modem have a part number ending in -002 (for example TSC3112-002). To check the part number of your TSC3 controller, remove the battery to view the label affixed to the left side of the battery compartment.

The phone must be "activated" before accessing the CDMA network. You may need to provide the MEID to your service provider before activation. This only needs to be done once. The phone must be registered in order to activate it.

To activate the phone on a Geo7X/TSC3 controller:

1. From the Trimble Access menu, tap *Internet Setup*.
2. Tap *GSM/CDMA settings*.
3. Select CDMA mode.
4. Tap *Activate*.

To create or edit an Internet connection using a phone/modem for a Trimble non-tablet controller:

1. From the Trimble Access menu, tap *Internet Setup*.
2. Select *Phone / Modem*.

Note - If you are using a controller with an integrated dual-mode modem, tap *GSM/CDMA settings* to switch the modem to the desired mode. If you are using a CDMA network, you must activate the phone before you can use it. See "To activate a Trimble controller on a CDMA network" above.

3. Tap the New/Edit button .
4. From the drop-down list, select the *Port*. This is the type of connection from the controller to the cellular modem. If you are using:
 - If you are using the controller's internal modem select *Internal modem*.

Tip - Access for the SIM card is under the battery on the TSC3 controller, and is through a port on the left side of the Slate / Geo7X / GeoXR controller.

 - If you are using a mobile Internet CF card, select *mobile internet modem*.
 - If you are using Bluetooth wireless technology, select *Bluetooth*.
 - If you are using a cable, select *Hayes Compatible on COM1*. If you are using a CU controller, you may need to select *Hayes Compatible on COM2*.

If you select *Bluetooth*, select the Bluetooth device from the drop-down list, which shows all modems that are paired with the controller. If your device does not appear in the list, you must pair the device. For more information, see [Bluetooth](#).

5. If your modem requires a PIN, select *My Modem Requires A PIN*, enter the PIN and then tap *Ok*.
6. Tap *Next*.
7. Select the details for your *Home network location*, *Service provider*, and *Plan*.
If these details are not in the list, you can manually configure them:
 - a. Tap *Add Service Provider*.
 - b. For the *APN*, either enter a value, select *None*, or use the *Select Access Point Name (APN) wizard*. In the wizard, select your country in the *Location* field, and select your *Provider and plan*. Tap *Accept*. The *APN* field is updated.
 - c. In the *Number to dial* field, enter **99***1#*. The **99***1#* is a standard access code for mobile Internet. If you are unable to connect using **99***1#*, contact your mobile Internet provider.
 - d. Enter a *Username* and *Password* if required by your network connection.

Tip - If you are using a TSC3/Slate/Geo7X/GeoXR controller and you have selected an internal modem, tap the *Detect* button to extract the service provider information detected by the SIM card.

8. Tap *Next*.
If you are using a controller with an integrated dual-mode modem, and if the modem is set incorrectly for your connection type, you are prompted to switch modes.
9. Enter a name for the connection setup and then tap *Finish*.

Notes

- If a connection of the same name already exists, you are prompted to overwrite the old connection. If you do not want to overwrite the old connection, tap *No* and then save

the new connection with a different name.

- *If the default service provider details are modified, the new details are saved to a [userserviceproviders.xml] file, located on the controller under [\Program Files\Trimble\Common]. If you want to recover the default values, you must remove this file from the controller.*
- *You cannot connect to the Internet using a CompactFlash card that has a modem PIN set. If you are using a CompactFlash card in the TSC2 controller, make sure that the SIM does not require a PIN.*
- *After three attempts to unlock the SIM card using an incorrect PIN, the SIM card is blocked, except for emergency calls. You are prompted to enter a PUK (Personal Unblocking Key) code. If you do not know the PUK for your modem, contact the supplier of the modem SIM card. After ten unsuccessful attempts to enter the PUK, the SIM card is invalidated and is no longer operable. When this occurs, you must replace the card.*

To connect, disconnect, or view the current state of your phone/modem internet connection on a Trimble non-tablet controller:

Once you correctly save a connection, you can use it to easily reconnect to the Internet:

1. From the *GPRS Connection* drop-down list, select the pre-configured connection.
2. If using Bluetooth technology, make sure that *Turn on Bluetooth* is selected.
3. Tap *Connect*.

Once the connection is established, the *Internet Setup* status bar updates to *Internet connection <connection name> established*, and the *Connect* button changes to *Hang up*. To disconnect, tap *Hang Up*.

When there is no connection, the *Internet Setup* status bar updates to *Internet not connected* and the *Hang Up* button changes to *Connect*. There is also an Internet connection indicator in the task bar, which is visible in other Trimble Access screens.

Tip - To enable other applications on your non-tablet controller, such as a web browser, to use the Internet connection you have set up in Trimble Access, make sure the *Programs that automatically connect to a private network should connect using* setting is set to **TrimbleNet**. To edit this setting, from the Windows Start menu, tap *Settings / Connections* and then tap the *Connections* icon. Select the *Advanced* tab and then tap *Select Networks*.

Notes

- *The current Windows Mobile Device Center or Wi-Fi connection to the controller is displayed in the Internet Setup wizard.*
- *When you have a Wi-Fi connection to a camera, the Internet setup wizard may incorrectly report that a Wi-Fi connection was established.*
- *To use a Wi-Fi connection to a camera and an Internet connection at the same time, you must first create the Internet connection and then create the connection to the camera.*

To create or edit an Internet connection using a Wi-Fi connection for a TSC3 / TSC2/ Geo7X / GeoXR controller:

1. From the Trimble Access menu, tap *Internet Setup*.
2. Select *Wi-Fi*. This enables Wi-Fi on the controller.

Note - *To disable Wi-Fi on the controller, select the Phone / Modem option.*

3. To configure and connect to Wi-Fi:

- On the TSC2 controller tap *Start / Settings / Connections / Wireless manager*.
- On the TSC3 controller tap *Start / Settings / Connections / Wi-Fi*.
- On the Trimble Geo7X controller tap the Trimble button, select *Start menu* and then select *Settings / Connections / Wireless Manager*. Tap *Menu* and then select *Wi-Fi Settings*.
- On the Trimble GeoXR controller tap the Trimble button, select *Start menu* and then select *Settings / Connections / Wi-Fi*.

If you have already configured and connected to the network, the controller automatically connects to this network if it is in range.

Connecting to the Internet on a Trimble tablet

The Trimble tablet has a dual-mode cellular modem. If you are using a CDMA network, you must activate the phone before you can use it. For more information, refer to the Support Note "Yuma 2: Activation of CDMA/Verizon Connectivity" available from www.trimble.com.

The exact steps for connecting to the Internet on a third-party tablet depend on the utilities installed with the operating system. Use the steps below as a guide, but for detailed information refer to the documentation provided with your tablet.

Connect the tablet to the Internet using one of the following methods:

- An external phone or modem connected using Bluetooth wireless technology
- The tablet's internal cellular modem
- The tablet's integrated Wi-Fi radio

To create a new network connection on the Trimble tablet using a phone or modem:

Note - *If you are using an external phone or modem connected using Bluetooth technology, make sure that you have paired with your Bluetooth device before creating a network connection.*

1. From the main Trimble Access menu, tap *Settings / Connect / GNSS contacts*.
2. From within GNSS contacts, tap the arrow on the right of the *Network connection* field.
3. From the Network connection page, tap *Add*.
4. Enter a *Name* for the network connection.
5. If you are using:
 - An external phone or modem connected using Bluetooth, select a *Bluetooth modem* from the list of paired devices.
 - The tablet's internal cellular modem, select the *Controller internal modem* check box.
6. For the *APN*, either enter a value, select *None*, or use the *Select Access Point Name (APN)* wizard. In the wizard, select your country in the *Location* field, and select your *Provider and plan*. Tap *Accept*. The *APN* field is updated.
7. In the *Number to dial* field, enter **99***1#*. The **99***1#* is a standard access code for mobile Internet. If you are unable to connect using **99***1#*, contact your mobile Internet provider.

8. Enter a *Username* and *Password* if required by your network connection.
9. Tap *Accept* to create the new network connection.

Notes

- *To view the settings of an existing network connection, highlight the connection and then tap the Edit softkey.*
- *To create a network connection outside of GNSS contacts, use Internet Setup from Trimble Access menu or select Settings / Connect / Internet Setup. Internet Setup will take you directly to the Windows Network and Sharing Center.*

To create or edit an Internet connection using a Wi-Fi connection for the Trimble tablet:

1. From the Trimble Access menu, tap *Internet Setup*.
2. The *Windows Network and Sharing Center* screen is displayed. Select *Set up a new connection or network* to create a Wi-Fi network. See Windows Help for further details.

Bluetooth

You can configure a Trimble controller to connect to these devices using Bluetooth wireless technology:

- a Trimble R/5000 GNSS receiver
 - Note** - *Trimble 5700 receivers do not support Bluetooth wireless technology.*
- an [auxiliary GPS receiver](#)
- a conventional instrument that has Bluetooth wireless technology
- a TDL2.4 radio
- an active target
- supported Bluetooth [laser rangefinders](#)
- supported Bluetooth [echo sounders](#)
- another Trimble controller
- a Bluetooth-capable cellular modem
- a [Zebra P4T mobile printer](#)

The steps for connecting a controller to another device are listed below. For more information about a particular step, see the sections below.

1. Turn on both devices.
2. [Enable Bluetooth on the device.](#)
3. [Enable Bluetooth on the controller.](#)
4. [Start a scan on the controller.](#)
5. Once the scan is complete, [pair with the device.](#)
6. [Connect the Trimble Access software to the paired device.](#)

Enabling Bluetooth on the device

For a...	Do the following:
Trimble R / 5000 series GNSS receiver	Refer to the documentation provided with your receiver.
Conventional instrument	<p>Trimble VX Spatial Station or Trimble S Series total station</p> <ul style="list-style-type: none"> Turn on the instrument and then use the Face 2 display on the instrument to turn on Bluetooth wireless technology. <p>Note - The menu of the Face 2 display on the instrument can only be accessed when the instrument is On and the General Survey software is not connected. From the electronic level screen, select [Set] to access the menu and configure Bluetooth wireless technology.</p> <p>Trimble M3 total station</p> <ol style="list-style-type: none"> Turn on the instrument and then tap [Start / Programs / TSMODE]. Tap [Sett.]: From the [Comm.] tab, set the [Port] to Bluetooth. Tap [OK] and then exit. Tap [Start / Settings / Control panel]. Tap [Bluetooth Device Properties]: From the [Power] tab, select [Enable Bluetooth] and [Discoverable]. Tap [OK] and then exit. <p>Other conventional instruments</p> <p>Refer to the documentation provided with your instrument.</p>
TDL2.4 radio	<p>On the TDL2.4, press the Radio button for 2 seconds to make it discoverable. The blue and red LEDs will blink, indicating the radio is ready to be paired with.</p> <p>Note - If you press and hold the radio button for longer than 10 seconds then all stored Bluetooth pairings in the TDL2.4 are cleared. You will need to recreate any Bluetooth pairings between the TDL2.4 and your controller(s).</p>
Active target	Bluetooth is always enabled when the active target is on.
Laser rangefinder	Refer to the table in Configuring the survey style to use a laser rangefinder .
Echo sounder	Refer to the documentation provided with your echo sounder.
Zebra P4T printer	See Setting up and using the P4T printer .
Another Trimble controller	See Enabling Bluetooth technology on the controller below.
A cellular modem	On the cellular modem, select the option to make the cellular modem discoverable. For more information, refer to the documentation provided with your modem.

Enabling Bluetooth technology on the controller

Note - If you are connecting a controller to another controller, complete these steps on **both** controllers.

1. From the Trimble Access menu, tap *Settings / Connect / Bluetooth*.
2. Refer to the table below for specific steps for your controller(s):

For a...	Do the following:
Trimble tablet	Tap the arrow in the system tray. If the Bluetooth icon is grayed out, tap the Bluetooth icon and then tap <i>Turn adapter on</i> .
TSC3/Geo7X/GeoXR/Slate	Tap the [Mode] tab and then make sure that the [Turn on Bluetooth] and [Make this device visible to other devices] check boxes are selected.
TSC2 controller	Make sure that the [Turn on Bluetooth] and [Make this device discoverable to other devices] check boxes are selected.
Trimble CU (Model 3) controller	Select the <i>Power</i> tab and then make sure that the [Enable Bluetooth] and [Discoverable] check boxes are selected.
Trimble CU controller	Make sure that the [Enable Bluetooth] check box is selected.

Enabling Bluetooth automatically

You can automatically enable Bluetooth technology when required. This allows General Survey to switch on Bluetooth should Bluetooth become disabled by actions outside of Trimble Access. To do this, tap *Settings / Connect / Bluetooth* from the Trimble Access menu, and then select the *Automatically enable Bluetooth* check box.

Starting a scan on the controller

Note - If you are connecting a controller to another controller, complete these steps on **one** controller. To make it easier to identify the correct controller when scanning, give the controller a unique name (see [Giving your controller a unique name](#)).

In the same screen where you enabled Bluetooth on the controller (*Settings / Connect / Bluetooth*):

For a...	Do the following:
Trimble tablet	Tap [Add a device].
TSC3/Geo7X/GeoXR/Slate	Tap the [Devices] tab and then tap [Add new device...].
TSC2 controller	Tap the [Devices] tab and then tap [New Partnership...].
Trimble CU (Model 3) controller	Tap the [Scan Device] tab and then tap [Scan].
Trimble CU controller	Tap [Scan Device].

The controller searches for other Bluetooth wireless technology devices within range.

Notes

- A device does not respond to a scan if it is already connected through Bluetooth wireless technology.
- Do not perform a scan on more than one controller at a time. A Bluetooth device cannot respond if it is scanning.

Pairing a controller with a device

To pair with a cellular modem, see [Pairing a controller with a cellular modem](#).

To pair a controller with any device except a cellular modem, use the steps below.

1. Once the scan is complete, highlight the Bluetooth device to connect to and then:

For a...	Do the following:
Trimble tablet	<ol style="list-style-type: none"> 1. Tap [Next]. 2. Unless prompted for a passkey, select [Pair without using a code]. 3. If you are pairing with a controller, tap [OK] to accept the pairing with the Trimble tablet, enter the code shown on the Trimble tablet, tap [Next] and then tap [Finish]. 4. Once the device driver software is installed (if required), tap [Close].
TSC3/Geo7X/GeoXR/Slate	<ol style="list-style-type: none"> 1. Tap [Next]. Do not enter a passkey unless prompted. 2. Enter a display name for the device and then tap [Done].
TSC2 controller	<ol style="list-style-type: none"> 1. Tap [Next]. Do not enter a passkey unless prompted. 2. Enter a display name for the device and then tap [Finish].
Trimble CU (Model 3) controller	<p>Tap the --> softkey to make it a Trusted device.</p> <p>When connecting one controller to another controller, you do not need to Authenticate the device. When the authentication message appears, tap [No].</p>
Trimble CU controller	<p>Note - To avoid time-out issues when pairing with a Trimble CU controller, Trimble recommends that you use a short pairing code and enter the code quickly.</p>

2. Tap [OK].

Passkeys

Some devices prompt you for a passkey. Enter the PIN/passkey provided by the manufacturer. The default passkey for a:

- Trimble R/5000 series GNSS receiver is 0000, although a passkey is usually not required.
- Trimble LaserAce 1000 or MDL LaserAce laser rangefinder is 1234.
- Ohmex SonarMite echo sounder is 1111.

For passkeys for other devices, refer to the documentation provided with the device.

Connecting the Trimble Access software to the paired device

Complete these steps for all devices except a cellular modem:

1. From the Trimble Access menu, tap *Settings / Connect / Bluetooth*.
2. Select the device to connect to from the appropriate field.

If Auto connect is enabled, the Trimble Access software connects to the device within a few seconds. Otherwise, start a survey to connect to the device.

Notes

- To connect the TDL2.4 to a Trimble VX Spatial Station or Trimble S Series total station, you must configure the TDL2.4 to use the same *radio settings* as the instrument.
 - When connecting to another Trimble controller, you must select the device name from the *Send ASCII data to field* on the controller that is **sending** the data. When you tap *Accept*, the controllers are configured to *send and receive ASCII data*.
3. Tap *Accept*.

Note - Unless you change the setting in the device field in the Bluetooth screen, the controller automatically connects to the selected device the next time you turn on both devices.

Pairing a controller with a cellular modem

To pair with a cellular modem you must establish a secure connection.

1. Once the scan is complete, highlight the cellular modem to connect to and then:

For a...	Do the following:
Trimble tablet	Tap [Next].
TSC3/TSC2/Geo7X/GeoXR/Slate	<ol style="list-style-type: none"> 1. Tap [Next]. 2. Enter a passkey of your choice (for example, 1234) to establish a secure connection. <p>Note - Do not tap [OK] until you complete step 2.</p>
Trimble CU controller	<ol style="list-style-type: none"> 1. Tap the --> softkey to make it a Trusted device. 2. When prompted to authenticate the device, select [Yes]. 3. When the [Enter Pin] dialog appears, enter a PIN of your choice, for example, 1234. <p>Note - Do not tap [OK] until you complete step 2.</p>

2. On the cellular modem, select the appropriate option to accept a pairing request.

Note - The controller **must** become a paired/trusted device on the phone.

3. To complete pairing the devices:

For a...	Do the following:
Trimble tablet	<ol style="list-style-type: none"> Select [Create a pairing code for me] to see a pairing code. On the cellular modem device: Enter the code shown on the Trimble tablet and then tap [OK]. On the Trimble tablet, tap [Close] once the device driver software is installed (if required).
TSC3/TSC2/Geo7X/GeoXR/Slate	<ol style="list-style-type: none"> Tap [Next]. Enter a display name for the device and then tap [Finish] / [Done].
Trimble CU controller	Tap [OK] on the [Enter Pin] dialog.

The cellular modem prompts you to add the controller as a paired device and allows you to enter the corresponding PIN you selected in step 1.

The controller is now listed as a paired device on the cellular modem, and the cellular modem is added to the list of trusted devices on the controller.

4. Tap [OK].

Note - If you use the General Survey software to dial a base station directly using a Bluetooth cellular phone, do not run [Bluetooth2Mobile.exe]. If you do, the software cannot connect to the modem; the error message *Connection failed* appears.

To connect to the Internet, you must create a dialing location and start a mobile Internet connection. For more information see [Connecting to the Internet](#).

To use a cellular modem for real-time surveying, see [Cellular modem – Overview](#).

Giving your controller a unique name

You can give your controller a unique name. This makes it easier to identify when searching for it in a Bluetooth scan.

To do this:

For a...	Do the following:
Trimble tablet	Go to [Windows Start \ Control Panel \ System]. Tap [Change settings], enter a new computer name in the [Computer Name] tab and then tap [Change...]. Tap [OK] and then tap [OK] again to confirm restarting the computer. Tap [Close] and then tap [Restart Now].
TSC3/TSC2	Go to [Start \ Settings \ System \ About]. Tap the [Device ID] tab and change the [Device Name] field, and then tap [Ok]. Press and hold the power key to perform a soft reset on the controller.
Geo7X/GeoXR	Tap the Trimble button, select <i>Start menu</i> and then select [Settings \ System \ About]. Tap the [Device ID] tab, change the [Device Name] field and then tap [Ok]. Press and hold the power key to perform a soft reset on the controller.

For a...	Do the following:
Slate controller	Press the Windows button to access the [Start] menu and select [Settings \ System \ About]. Tap the [Device ID] tab and change the [Device Name] field, and then tap [Ok]. Press and hold the power key to perform a soft reset on the controller.
Trimble CU (Model 3) controller	Go to [Start \ Settings \ Control Panel \ System]. Tap the [Device Name] tab, change the [Device name] field and then tap [Ok]. To reset the controller, hold down the Power key and then select [Options / Reset].
Trimble CU controller	go to [Start \ Settings \ Control Panel \ System]. Tap the [Device Name] tab and change the [Device name] field, and then tap [Ok]. To reset the controller, go to [Start \ Programs \ Utilities \ Reset \ Soft Reset].

Compass

If your Trimble [controller](#) includes an internal compass, you can use it when staking out a position or navigating to a point. The compass provides direction when you initially start stakeout and when you are close to the stakeout point and viewing the bullseye screen. After you first start stakeout, but before you get close enough to view the bullseye screen, positions are used from the GNSS or total station which give a more accurate heading.

When the compass is enabled, the following enhanced North arrow is displayed:

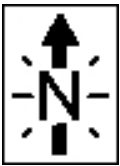

To disable the compass when you are near magnetic fields that may cause interference, select *Navigate to point / Options* or *Stakeout / Options*. See [Navigate to point](#) or [Stakeout options](#).

Compass calibration

Because the performance of the compass is impacted by magnetic fields, Trimble recommends re-calibrating the compass when the controller is taken into different environments.

To configure the magnetic declination, select *General Survey / Jobs / Properties of job / Cogo settings*. See [Magnetic declination](#).

To calibrate the controller's internal compass:

1. Select *Settings / Connect / Compass*.
2. Follow the on-screen steps 1 through 5 to calibrate the compass.
3. To exit the calibration process, tap *OK*.

Transferring files between controllers

You can use the Beam program on Microsoft Windows Mobile controllers to transfer any type of file between two Trimble non-tablet controllers, or from a Trimble non-tablet controller to an office computer using Bluetooth wireless technology.

Note - This topic does not apply to Trimble CU controllers. To transfer files from a CU controller to an office compute, you must use the Trimble Data Transfer utility or Windows Mobile Device Center. For more information, see *Using Bluetooth to Connect a Trimble CU to an Office Computer*.

1. Enable Bluetooth wireless technology on the controller/s.
 - On a Slate and TSC3 controller, press the Windows Start button to open the Start menu and then tap [Settings / Bluetooth]. Select [Mode] and make sure that the [Turn on Bluetooth] and [Make this device discoverable to other devices] check boxes are selected.
 - On a TSC2 controller, press the Window button and select [Settings / Connections / Bluetooth].
Make sure that the [Turn on Bluetooth] and [Make this device discoverable to other devices] check boxes are selected.
 - On a Geo7X/GeoXR controller, tap the Trimble button, select *Start menu* and then tap [Settings / Bluetooth].
Tap the [Mode] tab and make sure that the [Turn on Bluetooth] and [Make this device discoverable to other devices] check boxes are selected.
2. Close the General Survey software. Otherwise, the file transfer may fail.
3. On the controller that is to **send** the file, select [Start / Programs / File Explorer]. Browse to find the file to send.
4. Set up the device that will **receive** the file.
 - If you are sending to a controller, browse to [Start / Settings / Connections / Beam] and make sure that the *Receive all incoming beams* check box is selected.
 - If you are sending to an office computer, you must initiate the computer to receive a file.
5. On the controller **sending** the file, tap and hold on the file and then tap [Beam File]. You can select only one file at a time to send.
6. The controller scans for devices within range. Select the device that you want to send the file to.
7. On the receiving device, accept the file. The file is transferred.

For help with Bluetooth issues, go to [Troubleshooting](#).

Language

To change the language of the General Survey software:

1. Transfer the language file to the controller.
2. From the Trimble Access menu, tap *Settings / Languages*.

3. Choose the required language from the list.
4. Restart the General Survey software.

Select the *Use railroad terminology* option to use the following railway-specific terms if you are surveying a railway:

- *Slew* for *Go* when measuring your position relative to a string or when staking a station on a string.
- *Lift* for *V.Distance*

Select the *Use chainage distance terminology* option to use the term *Chainage* instead of *Station* for the distance along the road or tunnel.

Sound events

Sound events are prerecorded messages that notify you of an event or action that has occurred. They correspond with status line messages, and common error and warning messages.

Sound events are stored as .wav files. You can customize your own sound events by replacing or deleting the existing .wav files located in the Program Files\General Survey\Languages\[your language]\Sounds folder.

Tip - Use the Recorder application provided in Trimble controller except the CU to record your own sound events. Alternatively, transfer .wav files from the office computer to the controller using Data Transfer or Windows Mobile Device Center.

To turn all sound events on or off:

1. From the Trimble Access menu, tap *Settings / Languages*.
2. Select the *Play sound events* check box to turn on sound events, or clear it to turn them off.

Templates

Use templates to create a template of job properties to be used for a new job.

Creating a new template

1. From the Trimble Access menu, tap *Settings / Templates*.
2. Tap *New*.
(To edit or review a template, highlight the template name and then tap *Edit*.)
3. Enter a template name.
4. Use the *Copy from* field to copy the job properties from the *Last used job* or an existing template.
5. Edit the properties for the template as required.
6. Tap *Accept*.

Importing a template from another job

1. From the Trimble Access menu, tap *Settings / Templates*.
2. Tap *Import*.
3. Select the job and then tap *OK*.
4. Enter the template name and then tap *OK*.

Tip - Use *Rename* or *Delete* to rename or delete a template.

Auxiliary GPS

Select an auxiliary GPS receiver. Choose from:

- *None*
- *Internal GPS* - for supported controllers
- *Trimble GNSS card* - for the TSC2 controller only
- *Custom* - set the controller port as appropriate

When using Bluetooth wireless technology to connect the controller to a *Custom* auxiliary GNSS receiver, from the Trimble Access menu, tap *Settings / Connect / Bluetooth* and then select the receiver in the *Connect to auxiliary GPS* field. For more information, see [Bluetooth](#).

Conventional Survey Instruments

Conventional Instrument menu

If the controller is connected to a conventional instrument, the conventional *Instrument* menu is shown. Available options depend on the type of instrument that is connected.

Conventional instruments that can be connected to the controller running Trimble Access are:

- Trimble VX Spatial Station
- Trimble S Series total stations: S8/S6/S3 and S9/S7/S5
- Trimble mechanical total stations: M3, M1
- Trimble 5600 total station
- Some third-party total stations

Note - If a GNSS receiver is also connected and you are performing an integrated survey, additional items appear in the *Instrument* menu. For more information, see [GNSS Instrument Menu](#).

For more information on conventional instrument settings, see the following topics:

[Navigate to point](#)

[Station setup details](#)

[Electronic level](#)

[EDM settings](#)

[Laser pointer](#)

[Turn to](#)

[Joystick](#)

[Tracklight](#)

[Instrument settings](#)

[Instrument adjustment](#)

[Survey Basic](#)

[Instrument functions](#)

[Target tracking](#)

[Target controls](#)

[Autolock, FineLock, and Long Range FineLock technology](#)

[GPS search](#)

[Interrupted target measurement](#)

[Video](#)

[Data output](#)

[Radio settings](#)

[AT360 eBubble options](#)

[V10 panorama](#)

[Camera](#)

[Battery status](#)

Navigate to point

If the controller is connected to a GNSS receiver, or you are using a controller with internal GPS, you can navigate to a point. Using GNSS / GPS, you can navigate to a point without a survey running.

If you are running a conventional survey, you can also navigate to a point. During the conventional survey, if the controller is connected to a GNSS receiver, or you are using a controller with internal GPS, you can continue navigating to a point if you lose lock. Tap the *GNSS* button and then navigate to the point.

When you start the *Navigate to point* function, it uses the settings in the last GNSS survey style that you used.

CAUTION - To ensure that internal GPS is available on a TSC3 or Trimble Slate controller, the GPS format must be set to *NMEA* (this is the default format). If the GPS format is set to *SiRF Binary*, you cannot use the internal GPS. To set the format press the *Windows* button to access the *Start* menu and then tap *SatViewer*. In the *GPS* tab, make sure that the *NMEA* option is selected.

Notes

- *No configuration is required for the Geo7X/GeoXR controller or a Trimble tablet.*
- *When using a controller with internal GPS, a connected GNSS receiver is always used in preference to the internal GPS.*
- *If you are using a GNSS receiver that can track SBAS signals, when the radio link is down you can use SBAS positions instead of autonomous positions. To use SBAS positions, set the *Satellite differential* field in the survey style to *SBAS*.*

Navigating to a point

1. Do one of the following:
 - From the map, select the point you want to navigate to. Then tap and hold on the map and select *Navigate to point* from the shortcut menu.
 - Select *Instrument / Navigate to point* from the main menu.
2. Fill in the other fields as required and then tap *Start*. The graphical display screen appears.

3. Use the arrow to navigate to the point, which is shown as a cross. When you are close to the point, the arrow disappears and a bull's-eye symbol appears. A grid also appears and changes scale as you move closer to the target.
4. When you are on the point, the bull's-eye symbol covers the cross.
5. Mark the point if required.

Tips

- Tap *Position* and then *Store* to store a point.
- If navigating with a Trimble controller that has an internal compass, you can use the internal compass to aid navigation. See [Compass](#) for further details.

Station setup details

To view the instrument type and current station setup information when the controller is connected to a conventional instrument, select *Instrument / Station setup details* from the main menu.

Alternatively, if you are using a mechanical instrument (not a servo or robotic instrument), tap the Instrument icon on the status bar.

Electronic level

The electronic level is available when connected to Trimble instruments.

Leveling an instrument electronically from startup

1. Plumb the instrument.
2. Use the tripod legs and the tribrach bubble to roughly level the instrument.
3. Start the instrument.
4. If required, establish a connection between the controller and the instrument.

The Electronic level screen appears.

If the instrument is not level enough, you may get a tilt error. Roughly level the instrument with the tribrach circular bubble to bring the electronic level into range.

5. Turn the foot screws to center the bubbles for the sighting and trunnion axis.
6. To complete the leveling process, tap *Accept*.

When General Survey connects to a Trimble 5600 instrument, the compensator is not reinitialized if it was initialized within the last 2 hours and if the instrument level has not changed by more than 30 seconds.

Leveling an instrument electronically during a survey

1. From the main menu, select *Instrument / Electronic level*.
2. Turn the foot screws to center the bubbles for the sighting and trunnion axis.

On the Trimble M3 and 3600 total station, the laser plummet is also activated while the Electronic level screen is open.

WARNING - If accuracy is important, do not disable the compensator. If you do disable the compensator, horizontal and vertical angles in the instrument are not corrected for mis-levelment errors.

EDM settings

Select *Instrument / EDM settings* to configure electronic distance meter settings.

Depending on the instrument that the controller is connected to, the following functions may be available:

- [Direct Reflex](#)
- [Laser pointer](#)
- [3R high power laser pointer](#)
- [Blink laser](#)
- [Prism standard deviation / DR standard deviation](#)
- [DR minimum and maximum distance](#)
- [Long range](#)
- [Laser alignment](#)
- [Weak signal](#)
- [10Hz tracking](#)

Direct Reflex

To enable or disable direct reflex (DR) measurement, select *Direct Reflex*.

When using DR with a Trimble total station, Target DR is dedicated for DR use. You must configure the prism constant and target height appropriately.

When you turn on DR, the software automatically switches to Target DR.

Tip- For fast access to configure the EDM settings, tap the instrument icon in the status bar and then tap and hold on the DR icon.

When you turn off DR, the software returns to the last used non-DR target. If the last used target has been deleted, the software uses Target 1.

Alternatively, select *Target DR* to enable DR. Select *Target 1* to disable DR and return the instrument to its previous state.

The software supports up to six preconfigured targets, but only one DR target. For more information, see [Target details](#).

Laser pointer

To enable or disable the laser, select *Laser Pointer*. For more information, see [Laser pointer](#).

To streamline the process of locating a prism in dark environments, enable the laser pointer in the EDM setting screen and enable the *LaserLock* check box in the *Target controls* screen. For more information, see [Autolock, FineLock, and Long Range FineLock technology](#).

3R high power laser pointer

To enable or disable the high power laser pointer when using a Trimble S8 total station with the high power laser pointer option, select *3R high power laser pointer*. For more information, see [3R high power laser pointer](#).

Blink laser

To blink the laser when storing a point measured with DR, select the number of times the laser will blink in the *Blink laser* field.

Prism standard deviation / DR standard deviation

To define the acceptable accuracy of a measurement, enter a *Prism standard deviation* or *DR standard deviation* value, depending on the mode the instrument is in. When measuring to diffuse targets the standard deviation is displayed on the status line until the standard deviation satisfies the defined value. Once the standard deviation is satisfied, the measurement is accepted. To accept the measurement before the standard deviation is satisfied, tap *Enter* while the standard deviation is displayed on the status line

DR minimum and maximum distance

Enter a suitable DR minimum and maximum distance for your survey. Increasing the maximum distance will increase the time that it takes for a measurement to complete, even if the distance being measured is less than the specified maximum. The default maximum distance provides a balance between measurement time and range. Increase the maximum distance if you are working at longer ranges. To restrict the DR measurement range, enter a minimum and maximum distance to avoid a result from a distant or intermittent object.

Long range

To enable or disable long range mode, select *Long range*.

Use the long range mode when a strong instrument signal is required for measuring to targets more than one kilometer (about 0.6 miles) away.

Note - This feature is not available with the Trimble M3 total station and Trimble S3 total station.

Laser alignment

To take a measurement to where the laser is pointing, set the Laser alignment to *Horizontal* or *Vertical* (depending on the surface you are measuring to).

The laser pointer on a Trimble 5600 DR 200+ or DR 300+ instrument is not coaxial with the EDM. As a result, the location where the DR measurement is observed will not correspond to the location of the laser dot. To configure the software to measure to the laser dot, do the following:

1. Enable the laser pointer.
2. Select a laser alignment:
 - None DR measurement is observed below the laser dot.
 - Horizontal DR measurement is observed at the location of the laser dot provided that the measurement is on a horizontal surface.
 - Vertical DR measurement is observed at the location of the laser dot provided that the measurement is on a vertical surface.

The instrument will turn to the location of the laser dot and perform the measurement. Once the observation is completed, the instrument will turn the laser dot back to the observed point.

Weak signal

To accept measurements at a lower accuracy (that is, below the normal instrument specification), enable *Weak signal*.

10Hz tracking

To enable or disable 10Hz tracking select *10Hz tracking*.

Use 10Hz tracking when a faster update rate is required when using the TRK measuring method.

Notes

- Available for a Trimble S8 total station only.
- This option is only available if you are in both Autolock and Tracking mode. If you select DR or turn Autolock off when tracking, the software will default to normal tracking mode.
- Although tracking is faster the precisions will be null for the stored point.

Laser pointer

In a [Direct Reflex](#) survey, the laser pointer eliminates the need to look through the telescope when measuring DR points.

Note - When using a 5600 DR200+ instrument, the laser pointer is not coaxial with the telescope.

To turn on the laser:

1. To open the *Trimble Functions* screen, tap the Instrument icon in the status bar, or press and hold the Trimble key (if available) on the controller.
2. Tap the *Laser pointer* button.

Note - If DR is not yet enabled, turning on the laser pointer enables it. If you turn off the laser pointer, the instrument remains in DR mode. However, if you turn off DR mode, the laser is automatically turned off.

To streamline the process of locating a prism in dark environments, enable the laser pointer in the EDM setting screen and enable the *LaserLock* check box in the *Target controls* screen. For more information, see [Autolock, FineLock, and Long Range FineLock technology](#).

To automatically measure to the laser pointer with a non-coaxial 5600 DR200+ or DR300+, configure the Laser alignment setting in *Instrument / EDM settings*. For more information, see the section on [Laser alignment](#) in EDM settings.

3R high power laser pointer

The Trimble S8 total station can be equipped with a 3R high power laser pointer.

Notes

- *Even though the high-power laser pointer is not coaxial with the telescope, the instrument can automatically turn to measure to the laser pointer location. When you take a distance measurement and the 3R high-power laser pointer is on, a preliminary measurement is taken to determine the vertical angle to turn the instrument so that the distance is measured to where the high-power laser pointer is pointing. The instrument automatically turns to that location and takes the measurement. The instrument then turns so that the high-power laser again points to the measured position. The preliminary measurement is not stored. This function does not occur during continuous topo.*
- *The calculation of the vertical angle to turn to assumes the horizontal distance to the preliminary measurement is similar to the distance to the high power laser pointer location. To measure to the high power laser point when it is near the upper or lower edge of an object, consider using face 1 to take measurements at the lower edge of an object, and face 2 to take measurements at the upper edge of an object so that the preliminary measurement does not overshoot the object you are measuring to.*
- *When using a Trimble S8 total station with the high power laser pointer in tunnel set out, after setting out the point, tap 3R Laser to enable the high power laser pointer and reposition the instrument to indicate the mark on the tunnel surface.*

WARNING - The high power laser is a class 3R laser that emits laser radiation - do not stare into the beam or view directly with optical instruments.

Enabling or disabling the 3R high power laser pointer

1. To open the *Instrument functions* screen, tap the Instrument icon in the status bar.
If the controller is connected to a Trimble S8 total station equipped with the high power laser pointer option, the second button on the first row in *Instrument functions* shows a 3R high power laser pointer icon. If the button shows a Tracklight, Video, or LR FineLock icon, the controller is not connected to a Trimble S8 total station with the high power laser pointer.
2. Do one of the following:
 - If *Instrument functions* shows 3R HP Laser On, the high power laser pointer is off. Tap the button to enable the high power laser pointer.

- If *Instrument functions* shows 3R HP Laser Off, the high power laser pointer is already enabled. Tap the button to disable the high power laser pointer.

Turn to

If using a servo or [robotic instrument](#), you can use the *Turn to* options to control how the instrument moves.

1. From the main menu, select *Instrument / Turn to*. Alternatively, tap the Instrument icon on the status bar and then tap the *Turn to* button on the *Instrument functions* screen.
2. Select an instrument control method:

To turn the instrument...	enter...
to a horizontal or vertical angle only	the angle in the <i>Turn to</i> field.
to a horizontal and vertical angle	the horizontal angle in the <i>Turn to HA</i> field, and the vertical angle in the <i>Turn to VA</i> field.
to a specified point	a point name in the <i>Point name</i> field.
by distance	the distance from your current position to the point where the instrument lost lock. Use this to aid the <i>Search</i> option to locate the target when you have lost lock.

3. Tap *Turn*. The instrument turns to the angle(s) or point you entered.

To turn the instrument horizontally 90° to the right or left, or 180° use the appropriate softkey at the bottom of the screen.

To make the instrument locate and lock on to the target, tap *Search*. The message "Searching..." appears and the instrument starts searching for the target.

For information on other methods, see:

[Joystick](#)

[Preparing for a robotic survey](#)

[Map](#)

Joystick

If you are operating a robotic instrument at the remote end (target), use the *Joystick* softkey to turn the instrument towards the target when lock has been lost.





1. From the main menu, select *Instrument / Joystick*. Alternatively, tap the Instrument icon on the status bar and then tap *Joystick* button on the *Instrument functions* screen.
2. Tap an arrow on the screen or press the up, down, left, or right arrow keys to turn the instrument. The instrument turns in the direction indicated by the solid/filled arrow.

3. Depending on the robotic instrument being used, turn the instrument as described below:

For any Trimble servo total station except the Trimble 5600:

Tap and hold this arrow...	to turn the instrument...
left or right	horizontally (left or right)
up or down	vertically (up or down)
any diagonal arrow	horizontally and vertically

Notes

- To fine-tune the position of the instrument, tap the inner arrows. The inner arrows always turn at half of the minimum speed setting.
- How far the instrument turns depends on how long the button is held down.
- To change the direction tap the change direction button ( ,  ).
 - When the instrument icon is to the left of the prism icon, the instrument turns as if you are standing behind the instrument.
 - When the instrument icon is to the right of the prism icon, the instrument turns as if you are standing at the pole facing the instrument.
- To increase or decrease the turning speed, tap the left (decrease) or right (increase) speed arrows.

For a Trimble 5600:

Tap this arrow...	to turn the instrument...
first left or right	horizontally 12°
second left or right	horizontally 120°
first up or down	vertically 1°
second up or down	vertically 5°



Tap *Esc* or another arrow to stop the instrument from turning. The directional arrow becomes hollow. The instrument now points towards the target.

For a Leica TPS1100 series instrument:

Select the same direction to increase the instrument turning speed. The second directional arrow becomes solid. Select the same arrow again to decrease the speed.

Tap *Esc* or another arrow to stop the instrument from turning. The directional arrow becomes hollow. The instrument now points towards the target.

4. To make the instrument locate and lock on to the target, tap *Search*. The message "Searching..." appears and the instrument starts searching for the target.

When **GPS Search** is ready, a  softkey is available. To perform a GPS-aided search, tap .

The search results appear in the status line as messages:

- Target Locked - indicates that the target has been located and tracking locked.
- No Target - indicates that the target was not located.

For information on other methods, see:

[Turn to](#)

[Robotic instrument](#)

[Map](#)

Tracklight

Tip - For fast access to configure the Tracklight, tap the instrument icon in the status bar or press the Trimble key, and tap and hold on the Tracklight icon.

Turning on or turning off the tracklight

1. Tap the Instrument icon on the status bar.
2. Tap *Tracklight* in the *Instrument functions* screen.

Notes

- The Tracklight is not available when connected to an instrument equipped with a camera, a high power laser pointer or long range FineLock technology.
- When EDM power save is enabled on a Trimble 5600 DR Standard instrument, the Tracklight is not available.

Setting the speed of the guide-light

(Trimble S series, S3, and M3 total station only)

1. From the main menu, select *Instrument / Tracklight*.
2. Select the *Enable tracklight* check box.
3. From the drop down list in the *Speed* field, select:
 - *Slow, Fast, or Auto* for a Trimble S Series total station
 - *Slow, or Fast* for a Trimble S3 total station
 - *Slow, Medium, or Fast* for a Trimble M3 total station

Tip - When *Auto* is selected, the Tracklight flashes fast when the target is locked and slow if there is no target.

Setting the intensity of the guide-light

(Trimble 3600 or 5600 instrument only)

1. From the main menu, select *Instrument / Tracklight*.
2. Select the *Enable tracklight* check box.
3. From the drop down list in the *Intensity* field, select *Normal* or *High*.

Instrument settings

When connected to a Trimble instrument, select *Instruments / Instrument settings* from the main menu to access the *Instrument settings* dialog. Alternatively, tap and hold briefly on the instrument icon in the status bar and then release to enter *Instrument settings*.

Use this dialog to view and set specific controls on the instrument. Depending on the instrument that the controller is connected to, the following functions may be available:

- Instrument [name](#)
- Instrument [type](#)
- Instrument [firmware version](#)
- [Reticule illumination](#)
- [Target test](#)
- [Auto focus](#)
- [Face 2 backlight](#)
- [Signal volume](#)
- [EDM power save](#)
- [Service information](#)
- [PIN and PUK](#)

Instrument name, instrument type, and firmware version

In Trimble VX Spatial Station or Trimble S Series total station, tap *Name* to enter the instrument name. The instrument name is stored in the General Survey job file, and can be output to [Export custom format files](#).

The instrument type and firmware version details are also stored in the General Survey job file and output to DC files and Custom ASCII files.

Reticule illumination

Use the *Reticule illumination* control to illuminate the cross hairs. This is useful when the cross hair is not easily visible, for example when in a tunnel.

Target test

The target test is used primarily in Survey Basic when measuring a distance that is to be displayed as a dead record.

If the instrument is moved more than 30 cm from where the last measurement was observed, the HA and VA are updated but the SD reverts to "?" to avoid mistaking the next target's distance for the previously measured target's distance.

Auto focus

To enable Auto focus, select the *Auto focus* check box from *Instruments / Instrument settings*.

When Auto focus is enabled, the instrument automatically focuses whenever it automatically turns to a point.

Notes

- Auto focus is available only on an Auto focus-calibrated Trimble VX Spatial Station or Trimble S8 total station with instrument firmware R11.0.76 or later, and on a Trimble S6 total station with instrument firmware R12 or later.
- New instruments are shipped with Auto focus calibrated in the factory. When upgrading from an older version of the instrument firmware, you must first calibrate Auto focus using the *Adjustment / Autofocus calib.* function on the instrument face 2 display.
- If heights are not known, the computed slope distance cannot be determined and the instrument will be focused based on the horizontal distance instead.

Face 2 backlight

To enable the face 2 backlight when General Survey is running, select *Face 2 backlight*.

To enable the face 2 backlight when the Trimble CU is not attached to the instrument, press and hold (long press) the  key.

Signal volume

(Trimble 5600 only)

A returned signal sounds if a prism is detected. However, if you have activated EDM power save, you will not hear a signal.

EDM power save

(Trimble 5600 DR Standard, and 3600 only)

The power save mode turns off the EDM when the instrument is not measuring a distance. The instrument icon appears without the EDM indicator (*).

When the power save mode is off, the EDM is always turned on to receive a signal.

Note - If EDM power save is enabled on a Trimble 5600 DR Standard instrument, the tracklight is not available.

Service information

The Trimble VX Spatial Station or Trimble S Series total station should be serviced every 3000 hours or 13 months (whichever comes first). When the instrument is due for service, a service warning message appears.

When this message appears, you can still use the instrument, but please contact your local Trimble reseller at your earliest convenience to organize servicing.

To check when the instrument is due for the next service, tap *Instrument / Instrument settings / Service*.

Note - Service information is available only when using firmware version R10.0.58 or later. Customers upgrading to R10.0.58 will not have service information available until after the instrument has been serviced at an authorized Trimble service provider. For more information, contact your local Trimble reseller.

PIN and PUK

PIN lock using Trimble Access

To enable PIN lock security on the Trimble VX Spatial Station, or Trimble S Series total station, tap *PIN* and then enter and confirm the PIN. The PIN must be a 4-digit numeric value.

When the PIN function is enabled, the *Unlock instrument* screen appears when connecting to the instrument. Enter the PIN and then tap *Accept*.

When the PIN has been set, tap *PUK* and record the number. Use this number if you have forgotten your PIN. Ten incorrect attempts to unlock the instrument using a PIN results in the instrument being blocked. If this occurs, you are prompted for the PUK [Personal Unblocking Key] code to unblock the instrument.

Notes

- If the instrument is locked and you don't know your PIN or PUK, contact your local Trimble reseller for help.
- To change the PIN, tap *Instrument / Instrument settings - PIN*, enter the current PIN and then enter and confirm the new PIN.
- To remove PIN lock security, tap *Instrument / Instrument settings - PIN*, enter the current PIN and then tap *None*.

PIN lock security using the instrument

PIN lock security can also be enabled using the [Security] option on the Face 2 display on the Trimble VX Spatial Station or Trimble S Series total station. To do this:

1. Select [Setup/Level / Setup / Security - Change PIN]
2. Enter the current PIN. Select [Done] if no PIN has been set.
3. Enter and confirm the new PIN. The PIN must be a 4 digit numeric value.

When enabled, select the [Unlock Instrument] option on the Face 2 display and enter the PIN to establish a connection.

When the PIN has been set, select [Get PUK] and record the number. Use this number if you have forgotten your PIN. Ten incorrect attempts to unlock the instrument using a PIN results in the instrument being blocked. If this occurs, you are prompted for the PUK [Personal Unblocking Key] code to unblock the instrument.

Notes

- If the instrument is locked and you don't know your PIN or PUK, contact your local Trimble reseller for help.

- To change the PIN, select [Setup/Level / Setup / Security - Change PIN], enter the current PIN and then enter and confirm the new PIN.
- To remove PIN lock security, select [Setup/Level / Setup / Security - Change PIN] enter the current PIN and then enter and confirm 0000 as the new PIN.

Instrument adjustment

Select *Instrument / Adjust* from the main menu to complete the instrument tests. Depending on the instrument that the controller is connected to, the following tests may be available:

Compensator calibration

Collimation and Trunnion axis tilt

Autolock collimation

EDM constant

Compensator calibration

The dual axis compensator in a Trimble total station does not require initialization every time the instrument is leveled. However, Trimble recommends that you calibrate the compensator periodically, especially before you take precise measurements.

For any Trimble total station except the 3600, calibrate the compensator through the instrument face 2 display or on the controller through *Instruments / Adjust / Compensator calibration*. The instrument handle must be **attached** and the Trimble CU controller must be **unattached**. For information on calibrating through the Face 2 menu, refer to the documentation for your instrument.

Calibrating the compensator in a Trimble total station through the controller

1. Make sure that the instrument is accurately leveled and that the compensator is enabled.
2. Select *Instruments / Adjust / Compensator calibration*.
3. Follow the prompts to begin the calibration.
4. The message *Balancing instrument* appears followed by the message *Calibrating compensator*. The instrument then slowly rotates through 360°. If the calibration is successful, the message *Calibration complete* appears.
5. Tap *OK* to accept the calibration.

If the calibration is unsuccessful, the message *Calibration failed* appears. If the calibration fails, check the instrument setup, and re-level the instrument. Repeat the calibration. If it still fails, contact your Trimble service provider.

Calibrating the compensator in a Trimble 3600 instrument

1. Select *Instruments / Adjust / Compensator calibration*.
2. When prompted, turn the instrument 180° to 0°.
3. Tap *Accept*.

Note - This option is not available for the 5600 because the compensator is calibrated when the instrument is leveled.

Collimation and Trunnion axis tilt

On a Trimble total station, you must perform the HA VA Collimation and the Trunnion axis tilt adjustments together. To start the adjustment wizard, select *Instrument / Adjust / Collimation & Trunnion axis tilt*.

On a Trimble M3 total station start the adjustment wizard, select *Instrument / Adjust*.

Note - *Instrument / Adjust* is not available during a survey. End the current survey to perform an instrument adjustment.

The HA VA collimation, Trunnion axis tilt, and Autolock collimation instrument adjustments can be performed using General Survey, or through the Face 2 menu display. For more information, refer to the documentation for your instrument.

Trimble total station (except the M3)

1. Set up the instrument on a stable surface and follow the prompts to complete the test. Current adjustment values appear for each test (Horizontal collimation, Vertical collimation, and Trunnion axis tilt). Press the keys lightly to avoid bumping the instrument.
2. Aim at the target and take the first measurement.
3. Turn the instrument away and then re-aim.
4. Take the second measurement.

Note - Do not use Autolock during collimation or trunnion axis tilt tests.

Position the instrument as follows:

1. Collimation - at least 100 m from the target.
2. Collimation - less than 4°30 (5 gon) from the horizontal plane.
3. Trunnion axis tilt - at least 13°30 (15 gon) from the horizontal plane (for the 5600) or from the VA measured during collimation.

You must take a minimum of one observation on each face.

Tip - The standard deviations of the measured observations are displayed and updated during the measurement process. These values provide an indication of the consistency of your observations.

Final collimation values must be within tolerance of standard values. If not, the instrument needs to be adjusted mechanically. For more information, contact your local Trimble distributor.

Trimble M3 total station

Set up the instrument on a stable surface and follow the prompts to complete the test.

Current adjustment values appear for each test (Horizontal collimation, Vertical collimation, and Trunnion axis tilt). Press the keys lightly to avoid bumping the instrument.

Position the instrument as follows:

1. Collimation - at least 100 m from the target.
2. Collimation - less than 3° (3.33 gon) from the horizontal plane.

Carry out the following steps to complete the collimation and trunnion axis tilt adjustments:

1. Observe the collimation target on face 1 - a target less than 3° (3.33 gon) from the horizontal plane.
2. Observe the collimation target on face 2.
3. The collimation results are displayed.
 - Tap *Store* to save the new horizontal and vertical collimation settings, or
 - Tap *Trun.* to continue on to the trunnion axis tilt adjustment. If carrying out the trunnion axis adjustment continue with the following steps.
4. Observe the trunnion axis target on face 2 - a target at least 30° (33.33 gon) from the horizontal plane.
5. Observe the trunnion axis target on face 1.
6. At least three sets of observations are required to complete the trunnion axis adjustment. Repeat the observations to the collimation and trunnion axis targets two more times. Note that the observations made must agree within a 10" (0.003 gon) range.
7. Tap *Store* to save the collimation and trunnion axis adjustments and exit the adjustment process.

Final collimation values must be within tolerance of standard values. If not, the instrument needs to be adjusted mechanically. For more information, contact your local Trimble distributor.

Autolock collimation

This option is available only for instruments with *Autolock*, and should be performed after the HA VA Collimation adjustment has been completed.

Set up the instrument on a stable surface and follow the prompts. Press the keys lightly to avoid bumping the instrument. Ensure that there are no obstructions between the instrument and the target, which should be at least 100 m apart.

EDM constant

1. Select *Instruments / Adjust / EDM constant*.
2. Tap *Next* and then enter an appropriate EDM constant. The available range is -9.99 mm to +9.99 mm.
3. Tap *Store*.

Note - This option is available only for compatible Trimble total stations.

Survey Basic

Survey Basic is available when you connect a controller to a Trimble instrument.

You can use it as follows:

- If a General Survey job was created with a station setup, then Survey Basic can display raw data, and coordinates based on the station setup in the job.

- If a current station setup does not exist, you can:
 - Make simple distance or angular checks.
 - Define the Northing and Easting coordinates for the instrument point in Survey Basic, set the horizontal circle and then display coordinates for points observed using Survey Basic.
 - Key in the elevation for the instrument point and then display the elevation for points observed using Survey Basic.
 - Observe to a point with a known reference elevation to compute the instrument elevation and then display the elevation for points observed using Survey Basic.

Tip - To quickly access Survey Basic, from the Trimble functions screen, press **0**.

Note - You cannot store measurements in Survey Basic.

Survey Basic functions

The following table shows Survey Basic functions.

Tap the ...	to ...
Instrument icon on the status bar	access the <i>Instrument functions</i> screen
Target icon	set or modify the target height
Zero softkey	set the instrument horizontal circle to 0
Set softkey	set the horizontal circle
	set the target height
	set the reference elevation, and compute the instrument elevation
	set the instrument point coordinates, and instrument elevation
	set the instrument height
Options softkey	modify the correction values used in Survey Basic
Clear softkey	reset the angles back to live and clear the slope distance after a measurement
Display view button	switch the display between HA, VA, SD and HA, HD, VD
Press the ...	to ...
Enter key	measure a distance and fix the horizontal and vertical angles

Note - When a survey is running you cannot change:

- the instrument's horizontal circle
- the instrument point coordinates
- *correction values*

Computing the instrument point elevation from a known reference point using Survey Basic

1. Ensure that a current station setup does not exist and then start Survey Basic.
2. Tap *Set* and then enter the *Target height*, *Reference elevation*, and *Instrument height*.
3. If required, enter the *Horizontal angle* and instrument point *Northing* and *Easting*.
4. To measure the reference point, tap *Measure*. The instrument point *Elevation* is computed.
5. To return to Survey Basic, tap *Accept*.

To change the view on the data displayed, tap the arrow button.

Notes

- If the target height **or** instrument height is null, the General Survey software cannot calculate a VD.
- If target height and instrument height are **both** null, the General Survey software assumes zero for both and can compute the VD, but cannot compute the Elevation.
- If a station setup is computed using Survey Basic, a scale only projection of 1.0 is used to calculate coordinates.

Using Survey Basic to compute the inverse distance between two measurements

Inverse provides the ability to display inverse calculations between two measurements. You can configure inverse to compute Radial inverses from a single measurement to one or more other measurements, or Sequential inverses between successive measurements.

1. From the Survey Basic front screen tap the up arrow and then select *Inverse*.
2. Set the *Method* to either Radial or Sequential.
3. Enter a target height, if required.
4. Tap *Meas 1* to measure to the first point.
5. Enter a target height, if required.
6. Tap *Meas 2* to measure to the next point.
7. The inverse results are displayed.
 - Tap *Continue* to measure subsequent points. The process then continues from step 4.
 - Tap *Reset* to return to step 1.
8. Tap *Esc* to return to Survey Basic.

Notes

- If there is a survey running, the azimuth for each computed inverse will be displayed, and you will be able to select whether to display Grid, Ground or Ellipsoidal distances using the *Options* softkey, with the computations based on the settings in the current job.
- Without a survey running, and therefore no orientation, the azimuth is not available for computed inverses and all computations are based on simple cartesian computations with a scale factor of 1.0.
- Tap *Options* to configure the format of the grade display.

Instrument functions

To access the *Instrument functions* screen, do one of the following:

- tap the instrument icon on the controller screen
- select *Instrument / Instrument functions* from the General Survey main menu
- press and hold the Trimble key

The *Instrument functions* screen is available for conventional total stations. Use it to control commonly used instrument functions, and to change instrument settings. Depending on the instrument that the controller is connected to, the following functions may be available:

- STD (EDM Standard mode)
- FSTD (EDM Fast Standard mode)
- TRK (EDM Tracking mode)
- [Tracklight](#)
- [Video](#)
- [Laser](#) (Laser pointer for DR instruments)
- [3R High Power Laser Pointer](#) (Trimble S8 total station equipped with HP laser pointer only)
- [DR \(Direct Reflex\)](#) mode
- [Electronic level](#)
- [Joystick](#)
- [Turn to](#)
- Change face
- [Survey Basic](#)
- [Autolock](#)
- [FineLock](#) (Trimble S8 total station equipped with FineLock technology only)
- [Long Range FineLock](#) (Trimble S8 total station equipped with LR FineLock technology only)
- [Search](#)
- [Start Robotic](#)
- Disconnect

Instrument function icons

Some buttons within Instrument Functions have different states. If the button is highlighted in yellow, the function is enabled.

Disconnect

The Disconnect function is available when the controller is connected to a **Trimble VX Spatial Station or Trimble S Series total station** with no current station setup. To reconnect to the instrument,

select *Station setup* or tap the auto connect icon  in the status bar to restart auto connect. Auto connect is temporarily disabled when you use *Disconnect*.

Once you begin a survey, this option changes to *End survey*.

Instrument function shortcuts to the Instrument menu

Shortcuts to certain Instrument menu functions are available from *Instrument functions*. In the *Instrument functions* screen, tap and hold on the DR, Laser, Tracklight, Autolock, Search and Start Robotic icons to quickly access their Instrument menu configuration screens.

Geodimeter users

Former Geodimeter users can enter a Geodimeter program number in the *Instrument functions* screen to launch the corresponding General Survey function. For example, Geodimeter program 26 (Compute join) is the same as the Trimble function *Compute inverse*.

See [GDM CU Programs](#) for details.

Target tracking

Target tracking with the Trimble VX Spatial Station or Trimble S Series total station

You can configure the software to use an Active Target ID if you are using a Trimble VX Spatial Station or Trimble S Series total station with search capabilities and one of the following:

- [Trimble AT360 Active Track 360 target](#)
- [Trimble MT1000 MultiTrack target](#)
- [Trimble VX/S Series 360° prism](#)
- [Custom prism](#)

Ensure that the correct prism type and mode is selected in the target form. This will ensure that the appropriate correction values are applied to the slope distance and vertical angle for geocentric offset and prism constant.

See also:

[Target details](#)

[Target controls](#)

Trimble Active Track 360 target

The Trimble Active Track 360 (AT360) is a reflective foil target designed for use as an active tracker target. The AT360 includes a tilt sensor that enables eBubble support when connected to the controller with Bluetooth. The eBubble is used to check that the target is level. The tilt angle and tilt distance is stored with each observation.

For more information on connecting the AT360 to your controller, see [Bluetooth](#).

To enable active tracking with the AT360:

1. Tap the target icon on the status bar.
2. Select the *Target height* or *Prism constant* field to open the *Target* screen.
3. Set the *Prism type* to *Active Track 360*.

4. Set the *Tracking mode* to *Active*.
5. Set the *Target ID* to match the identification number in the Target ID on the robotic rover.

When connected to the AT360 using Bluetooth, changing the *Target ID* in the General Survey software automatically updates the target ID setting on the AT360 once you tap *Accept* in the *Target* screen. Likewise if you change the target ID on the AT360 and the current target is an AT360, then the *Target ID* is automatically updated on the controller.

Manual mode can be used if the battery in the AT360 needs charging and you do not have a replacement battery available. When using the AT360 in manual mode, Autolock is disabled and you must manually aim the instrument at the target.

Note - When you enable Autolock and the current prism is the Active Track 360 then the software automatically switches the tracking mode to Active if it is in manual mode.

Trimble MultiTrack target

When using the Trimble MultiTrack target, the **Tracking mode** can be set to:

- [Passive](#)
- [Active](#)
- [Semi-active](#)

The MultiTrack target should be used within the vertical angle tolerances shown in the following table:

Tracking mode	Vertical range
Active	+/- 15° from horizontal
Passive	+/- 30° from horizontal

Using the MultiTrack target outside these tolerances may degrade the accuracy of the measurement.

Note - If you use a Trimble VX Spatial Station or Trimble S Series total station with the Trimble MultiTrack target, you must upgrade the instrument to firmware version R7.0.35 or later. The Trimble VX Spatial Station or Trimble S Series total station firmware is available on www.trimble.com.

Tracking mode - Passive

If you do not operate in a reflective environment, set the *Tracking mode* to *Passive*.

1. Tap the target icon on the status bar.
2. Select the *Target height* or *Prism constant* field to open the *Target* form.
3. Set the *Prism type* to VX/S Series MultiTrack.
4. Set the *Tracking mode* to *Passive*.

Tracking mode - Active

If you operate in a highly reflective environment, or on a site with many prisms, set the *Tracking mode* to *Active* to ensure that you maintain constant lock to the correct target.

1. Tap the target icon on the status bar.
2. Select the *Target height* or *Prism constant* field to open the *Target* form.
3. Set the *Prism type* to VX/S Series MultiTrack.
4. Set the *Tracking mode* to *Active*.
5. Set the *Target ID* to match the identification number in the Target ID on the robotic rover.

Tracking mode - Semi-active

If you operate in a reflective environment, and require precise elevations, set the *Tracking mode* to *Semi-active* to ensure that you maintain constant lock to the correct target.

1. Tap the target icon on the status bar.
2. Select the *Target height* or *Prism constant* field to open the *Target* form.
3. Set the *Prism type* to VX/S Series MultiTrack.
4. Set the *Tracking mode* to *Semi-active*.
5. Set the *Target ID* to match the identification number in the Target ID on the robotic rover.

When the *Tracking mode* is set to *Semi-active*, the Target ID is used to track the prism, and then automatically switches to passive tracking mode when taking a standard measurement. This results in more precise vertical angle measurements.

When passive tracking is used when measuring, you must be aware that there is a risk of nearby reflective surfaces interfering with the measurement.

Trimble VX/S Series 360° prism or a custom prism

When using the Trimble VX/S Series 360° prism or a custom prism, the **Target ID** can be set to:

- **Off** - the ID is not checked.
- **Search** - check the ID when a search is initiated.
- **Search and measure** - check the ID when a search is initiated, and when a measurement is initiated.
- **Always** - the ID is constantly being checked by the instrument.

The Target ID has two "on" modes; on for 60 seconds, and on continuously. When *Check target ID* is set to *Always*, you must set the Target ID on the pole to "on continuously".

The target ID must be carefully aimed towards the instrument at all times.

For more information on how to configure the target ID on the Trimble pole, refer to the documentation for your instrument.

Note -*Target ID can be used for rounds observations. When you do this, make sure that each target in the rounds list can have a different target ID. These settings are retained for each individual target until the rounds observations are completed.*

Check the target ID - Search

If you operate in an environment with few reflective surfaces, but you want to ensure that if you do a search you will lock to the correct target, set *Check target ID* to *Search*.

1. Tap the target icon on the status bar.
2. Select the *Target height* or *Prism constant* field to open the *Target* form.
3. Set the *Prism type* to VX/S Series 360°.
4. Set the *Check target ID* to *Search*.
5. Set the *Target ID* to match the identification number in the Target ID on the Trimble Standard Rod.

When the *Check target ID* is set to *Search*, the Target ID is checked after a search is made to ensure that you are locked onto the correct target. If not, the General Survey software warns you and you can perform a new search for the correct target ID.

If you enable *Snap to target* and the instrument automatically detects the target, the instrument does not perform a search or check the Target ID.

The target ID must be carefully aimed towards the instrument when performing a search.

Check the target ID - Search and measure

If you operate in an environment with few reflective surfaces, but you want additional assurance if you do a search or when you measure that you will lock to the correct target, set *Check target ID* to *Search and measure*.

1. Tap the target icon on the status bar.
2. Select the *Target height* or *Prism constant* field to open the *Target* form.
3. Set the *Prism type* to VX/S Series 360°.
4. Set the *Check target ID* to *Search and measure*.
5. Set the *Target ID* to match the identification number set in the Target ID on the Trimble Standard Rod.

When the *Check target ID* is set to *Search and measure*, the Target is checked again before a measurement is made to ensure that the instrument is still locked onto the correct target. If not, the General Survey software warns you and you can then perform a new search for the correct target ID.

The target ID must be carefully aimed towards the instrument when taking a measurement.

Check the target ID - Always

If you operate in a reflective environment, and require precise elevations set *Check target ID* to *Always* to ensure that you maintain constant lock to the correct target.

1. Tap the target icon on the status bar.
2. Select the *Target height* or *Prism constant* field to open the *Target* form.
3. Set the *Prism type* to VX/S Series 360°.
4. Set the *Check target ID* to *Always*.
5. Set the *Target ID* to match the identification number in the Target ID on the robotic rover.

When the *Check target ID* is set to *Always*, the Target ID is used to actively maintain horizontal lock. The prism is used to maintain the vertical lock.

When passive tracking is used to maintain vertical lock to the prism, you must be aware that there is a risk of nearby reflective surfaces interfering with the vertical tracking.

Remote Measuring Target (RMT) ID - Target tracking with Trimble 5600

When you work on a site with multiple RMTs, configure the RMT channel ID to lock onto a specific RMT target.

Note – *This is only available on supported instruments.*

1. Tap the target icon on the status bar.
2. Select the *Target ID* field to open the *Target* screen.
3. Set the RTM ID in the General Survey software to match the ID set in the RMT. For more information, refer to the *Trimble 5600 Series User Guide*.

Tip - To lock to RMTs that do not support RMT ID, set the RMT ID to 4.

Leica search method

If you operate a Leica TPS1100 or TPS1200 instrument that supports *Power search*, you can configure the search method to use for performing a search.

The search methods available are:

- Spiral
- Power search

Use the method that best suits the environment you work in. For more information, refer to the instrument manufacturer's documentation.

Leica ATR mode

If you operate a Leica TPS1200 instrument that supports Low visibility and S-Range ATR modes, you can configure the ATR method used.

The available ATR modes are:

- Normal
- Low visibility on
- Low visibility always on
- S-Range on
- S-Range always on

Use the method that best suits the environment you work in. For more information, refer to the instrument manufacturer's documentation.

Target controls

Once you have defined the target in the *Target* screen, use the *Target controls* screen to configure how to track, lock, and measure to the target.

For more information, see:

[Autolock, FineLock, and Long Range FineLock technology](#)

[GPS search](#)

[Interrupted target measurement](#)

Autolock, FineLock, and Long Range FineLock technology

Configure *Autolock*, *Finelock*, and *Long Range Finelock* settings in the *Target controls* screen.

If Autolock is available on the instrument, use it to lock on to and track a remote target.

FineLock and Long Range FineLock technology provide better performance when measuring to static targets when there are two prisms close together. You can use FineLock and Long Range FineLock technology to lock to a target, but not to track or search for a target.

With a Trimble S8 total station with FineLock technology, you can use *FineLock* mode when measuring to a prism that is 20 m - 700 m away.

To measure to a prism that is 5 m to 60 m away, enable *Using FineLock lens aperture* and then fit the lens aperture accessory to the instrument.

With a Trimble S8 total station with Long Range FineLock technology, you can use *Long Range FineLock* mode when measuring to a prism that is 250 m - 2500 m away.

Note - *The separation between targets should not be less than 13' 45" (4 mrad).*

When using a Trimble S8 total station with FineLock technology, you can configure the Autolock button in *Instrument functions* to enable and disable Autolock, or to enable and disable FineLock technology.

Enabling or disabling Autolock

1. To open the *Instrument functions* screen, tap the Instrument icon in the status bar.
2. You can configure the second button on the third row in *Instrument functions* to be either an Autolock or a FineLock button.
 - If the button shows FineLock, it is configured as a FineLock button. To change it to Autolock, tap and hold briefly on the button. Once you release the button, the *Target controls* dialog appears. Set the *Target lock* to *Autolock* and then tap *Accept*.
 - If the button shows Autolock, it is already configured as an Autolock button.
3. Do one of the following:
 - If the button is not highlighted yellow, tap Autolock to enable Autolock.
 - If the button is highlighted yellow, tap Autolock to disable Autolock.

A search is automatically performed if a measurement is initiated when Autolock is enabled but the instrument is not locked to the target.

When **GPS search** is ready, a GPS-aided search is performed instead of a standard search.

To perform a standard search, pause GPS Search, or select *Search* available from the **Joystick** screen.

Select *Interrupted target measurement* and then enter an *Interrupt timeout* value if the measurement is likely to be interrupted, for example, when measuring in traffic.

Tip- For fast access to configure the Autolock and search settings, tap the instrument icon in the status bar or press the Trimble key, and tap and hold on the Search icon.

Note - Do not use Autolock during the collimation or Trunnion axis tilt tests. For more information, see *Instrument adjustment*.

Configuring additional Autolock controls

Snap to target, *Autosearch*, *LaserLock*, and *Predictive tracking time* provide additional Autolock controls, they are not available with FineLock or Long Range FineLock technology. To configure these settings, tap the Instrument icon in the status bar to view the *Instrument functions* screen and then tap and hold on the *Autolock* button. The *Target controls* screen appears, showing the following settings:

Autolock method

Select *Snap to target* to automatically lock on to a remote target if one is detected. This function was previously called *Advanced lock*. If you do not want to automatically lock onto a target, set the Autolock method to *Snap disabled*.

Autosearch

Select *Autosearch* to automatically perform a horizontal search when lock is lost to a remote target.

LaserLock

The LaserLock method streamlines the process of locating a prism in dark environments by enabling the laser pointer and then using Autolock to lock to the target when measuring. When the *Laserlock* checkbox is enabled, measuring to the prism automatically disables the laser and switches Autolock on. When the measurement is complete Autolock is switched off, and the laser is switched back on ready to help locate the next prism.

Predictive tracking time

This feature enables you to pass behind a temporary obstruction and have the instrument continue to turn, based upon the target's horizontal trajectory, when lock to the prism is lost.

If the trajectory is consistent and the prism re-appears from behind the obstruction within the defined time interval, the instrument will be aimed directly at the prism and lock is automatically regained.

After the specified time interval, the General Survey software reports that the target is lost and then takes corrective actions based on the current settings.

The instrument turns to where the target was last seen and then acts as follows:

If <i>Autosearch</i> is ...	and <i>Snap to target</i> is ENABLED, the instrument	and <i>Snap to target</i> is DISABLED, the instrument
On	Locks on to any target in the field of view. If there is no target, a search starts based on your search window settings.	Ignores any visible targets and starts a search based on your search window settings
Off	Locks on to any target in the field of view or waits until a target comes into the field of view and then locks onto it.	Ignores any targets in the field of view and does not start any search until you prompt it to do so.

Note - The General Survey software defaults are *Snap to target* ENABLED and *Autosearch* OFF.

You can configure the Predictive tracking time as follows:

- For standard robotic usage, Trimble recommends the default setting (1s).
This enables you to pass behind anything small blocking the line of sight between the instrument and the target (for example, trees, electrical posts, or vehicles) and then automatically regain lock.
- In environments with a number of reflective objects, you could set the predictive tracking time to 0s. For optimal performance, use this setting with *Snap to target* DISABLED.
With these settings, you are immediately informed if the line of sight to the correct target is obstructed. You can then ensure that you regain lock to the correct target.
- In environments where your target may be blocked for a few seconds at a time, you can use settings of 2s or 3s.
This enables you to pass behind larger objects blocking the line of sight between the instrument and the target (for example, small buildings) and then automatically regain lock.

If the instrument fails to regain lock onto the moving target, it returns to the location where it first lost lock and the predictive tracking began.

To change the Predictive tracking time:

1. Do one of the following:
 - From the main menu, select *Instrument / Target controls*.
 - From the *Instrument functions* form, tap and hold briefly on the **Autolock** or **Search** icon. When you release, the *Target controls* dialog appears.
2. Select the required time from the Predictive tracking time list.

Enabling or disabling FineLock technology

1. To open the *Instrument functions* screen, tap the Instrument icon in the status bar.
2. You can configure the second button on the third row in *Instrument functions* to be either an Autolock or a FineLock button.
 - If the button shows Autolock, it is configured as an Autolock button. To change it to FineLock, tap and hold briefly on the button. Once you release the button, the *Target controls* dialog appears. Set the *Target lock* to *FineLock* and then tap *Accept*.
 - If the button shows FineLock, it is already configured as a FineLock button.

3. Do one of the following:
 - If the button is not highlighted yellow, tap FineLock to enable FineLock.
 - If the button is highlighted yellow, tap FineLock to disable FineLock.

Using the FineLock lens aperture

CAUTION - When measuring less than 20 m, you must enable *Using FineLock lens aperture* and then fit the lens aperture accessory to the instrument.

1. Use the instructions above to configure FineLock technology.
2. Open the *Instrument functions* screen and then tap and hold briefly on the FineLock button. When you release it, the *Target controls* dialog appears. Enable the *Using FineLock lens aperture* check box and then tap *Accept*.
3. Fit the FineLock lens aperture accessory to the instrument.

You can now perform FineLock measurements to prisms less than 20 m away.

Note - The *FineLock lens aperture accessory* should only be used on Trimble S8 total station with firmware version R12.2 or later.

Enabling or disabling Long Range FineLock technology

1. To open the *Instrument functions* screen, tap the Instrument icon in the status bar.
If the controller is connected to a Trimble S8 total station equipped with Long Range FineLock technology, the second button on the first row in *Instrument functions* is the Long Range FineLock button.
If the button shows a Tracklight, Video, or High Power Laser Pointer icon, the controller is not connected to a Trimble S8 total station equipped with Long Range FineLock technology.
2. Do one of the following:
 - If the LR FineLock button is not highlighted yellow, tap LR FineLock to enable long range FineLock.
 - If the LR FineLock button is highlighted yellow, tap LR FineLock to disable long range FineLock.

Notes on FineLock and Long Range FineLock

- FineLock technology is available only on a Trimble S8 total station equipped with FineLock technology.
- Long Range FineLock technology is available only on a Trimble S8 total station equipped with Long Range FineLock technology.

The Long Range FineLock hardware is not coaxial with the telescope.

To eliminate the vertical errors associated with non-coaxial Long Range FineLock hardware, you must observe all observations to points on both face 1 and face 2.

- You can use FineLock technology only to prisms 20 m - 700 m away.

- If you use FineLock technology and you measure a distance of less than 20 m, General Survey detects that FineLock should not be used, the measurement fails, and the message *Target too close for FineLock* appears. You must disable FineLock technology when measuring less than 20 m.
- If you use FineLock technology to a target less than 20 m away, and a distance is not measured, General Survey uses FineLock technology because it cannot detect that it should not be used.
- Measurements taken with FineLock technology under 20 m are unreliable - do not use them.
- You can use Long Range FineLock technology only to prisms 250 m - 2500 m away.
 - If you use Long Range FineLock technology to measure a distance of less than 250 m, General Survey detects that Long Range FineLock technology should not be used, the measurement fails, and the message *Target too close for Long Range FineLock* appears. Use FineLock technology when measuring less than 250 m.
 - If you use Long Range FineLock technology to a target less than 250 m away, and a distance is not measured, General Survey uses Long Range FineLock technology because it cannot detect that it should not be used.
 - Measurements taken with Long Range FineLock technology under 250 m are unreliable - do not use them.
- FineLock and Long Range FineLock technology always take precedence over TRK, DR, or Autolock modes - you cannot use them at the same time.
 - If you enable FineLock or Long Range FineLock technology along with TRK, the observation is measured with STD mode.
 - If you enable FineLock or Long Range FineLock technology along with DR, the observation is measured with STD mode.
 - If you enable FineLock or Long Range FineLock technology when Autolock is already enabled, Autolock is automatically disabled.

If there are two prisms close together, and Autolock was enabled before setting FineLock or Long Range FineLock technology, check the pointing to the prism because Autolock may lock to the other prism before FineLock or Long Range FineLock is enabled.
- You can use FineLock and Long Range FineLock technology with *Averaged observations* with a Trimble S8 total station equipped with FineLock technology with firmware version R11 or later.

Tilttable RMT

(Trimble 5600 only)

Enable *Tilttable RMT* when you use a remote target tilted towards the instrument. Disable *Tilttable RMT* when you use a fixed vertical target. When disabled, the vertical angle measurement will be corrected for the small offset distance between the RMT and the prism center.

Autocentered search window and search window size

When performing a search with the Autocentered search window selected, General Survey uses the current horizontal and vertical angle of the instrument to set the center of the search window, and

the horizontal and vertical range to calculate the extents of the window. These extents are sent to the instrument each time it performs a search.

If you do not select the Autocentered search window, the search extents are not reset in the instrument.

To configure the top left and bottom right extents of the search window, point and measure with the instrument before starting the robotic survey. For more information, see [Preparing for a robotic survey](#).

FineLock tolerance window

FineLock technology locks onto targets only when they are within the FineLock sensor area. If the intended target cannot be found, FineLock 'auto-gain' increases slightly to attempt to find other nearby targets. However, this may not always be desirable.

The *FineLock tolerance window* limits the range that FineLock technology moves when trying to lock onto nearby targets. Targets outside this range are not locked to. Instead, a message shows that a target outside the defined tolerance was found.

The FineLock tolerance window you can configure is defined as a half window, where the maximum half window size is 4 mrad (13' 45"), which is the smallest separation allowed between targets when using FineLock technology.

To configure the FineLock tolerance window:

1. To open the *Instrument functions* screen, tap the Instrument icon in the status bar.
2. Tap and hold briefly on the FineLock (or Autolock) button. When you release it, the *Target controls* dialog appears.
3. Tap *Adv*, and then configure the FineLock tolerance window *Horizontal range* and *Vertical range*.
4. Tap *Accept*.

Note - The *FineLock tolerance window* is available only on Trimble S8 total station with firmware R12.2 or later.

GPS search

During a robotic survey, if the instrument loses lock to the target, you can use a GPS/GNSS receiver to help point the instrument.

You can enable GPS Search through any of the following:

- [a Trimble survey grade GNSS receiver](#)
- one of the following auxiliary GPS options:
 - [a Trimble controller with internal GPS](#)
 - [a Trimble GPS/GNSS card](#)
 - [any GNSS receiver](#) capable of outputting NMEA (GGA) through a serial or Bluetooth port to the controller:

The receiver must be able to output GGA messages through the NMEA protocol at 1 Hz.

For information on how to manually configure and connect to the receiver, refer to the receiver documentation.

GPS search is automatically enabled when you are:

- running an Integrated Survey
- using a Trimble controller with internal GPS

Note - When using a Trimble controller with internal GPS, a connected GNSS receiver is always used in preference to the internal GPS.

Enabling GPS search

Enabling GPS search using a Trimble survey grade GNSS receiver

1. Start the General Survey software and then establish a robotic connection between the Trimble controller and the Trimble total station.
2. From the main menu, select *Instrument / Target controls*.
3. Set the *3D* check box as required.
 - If *3D* is enabled, a 3D GPS Search position is computed, and the instrument can turn to the point both horizontally and vertically.
 - If *3D* is disabled, the instrument can only turn horizontally to the GPS Search position.
 - If the GNSS receiver is initialized in an RTK survey, or if SBAS is available, you can enable *3D* because the GNSS heights from a GNSS receiver should be accurate enough to turn the instrument's vertical angle.
 - If the GNSS receiver is producing autonomous positions, or if SBAS is **not** available, Trimble recommends that you disable *3D* to prevent incorrect GNSS heights causing inaccurate turning of the vertical angle.
4. Set the *Select data source* to *Trimble GNSS*.

In an integrated survey, the *Select data source* is automatically set to *Trimble GNSS* and the *3D* check box is selected by default.

When connecting the controller to the receiver through Bluetooth wireless technology, you must enable Bluetooth communications on the controller, scan for the Bluetooth device and then set the Bluetooth device in the *Connect to GNSS rover* field at *Settings/Connect/Bluetooth*.

If you use a cable to connect the Trimble CU to a GNSS receiver, connect the USB-to-serial cable to the Trimble CU robotic holder **before** you start the General Survey software. Otherwise, the COM port is not available.

GPS search is now configured. The [relationship between the GNSS positions and local positions](#) must now be resolved before you can use GPS search.

Enabling GPS search using a Trimble controller with internal GPS

By default GPS search is preconfigured for using the Trimble controller's internal GPS (that is, *GPS Search* is on, *Enable 3D* is off, the *Select data source* is set to *Auxiliary GPS*, and the *Receiver type* is set to *Internal GPS*). To change these settings:

1. Start the General Survey software and then establish a robotic connection between the Trimble controller and the Trimble total station.
2. From the main menu, select *Instrument / Target controls*.
3. Set the *3D* check box as required.
 - If *3D* is enabled, a 3D GPS Search position is computed, and the instrument can turn to the point both horizontally and vertically.
 - If *3D* is disabled, the instrument can only turn horizontally to the GPS Search position.

Trimble recommends that you disable *3D* to prevent inaccurate GPS heights from internal GPS causing inaccurate turning of the vertical angle. It may be preferable to turn horizontally only.

If the *Receiver type* is not *Internal GPS*, tap *Aux* to select it.

Note - When using a Trimble controller with internal GPS, the *Receiver type* is automatically set to *Internal GPS*.

GPS search is now configured. The [relationship between the GNSS positions and local positions](#) must now be resolved before you can use GPS search.

Enabling GPS search using a Trimble GPS/GNSS Compact Flash card

Note - A Trimble GNSS card can be used only in a TSC2 controller.

1. Make sure that the General Survey software is turned off and then insert the Trimble GNSS card into the port on the TSC2 controller.
 - If you insert the card after you start the General Survey software, select *Instrument / Target controls / GPS* and then tap *Reset* to reinitialize the card and GPS Search.

Note - The *GPS* softkey is available only when *GPS Search* is enabled.
2. Start the General Survey software and then establish a robotic connection between the TSC2 controller and the Trimble total station.
3. From the main menu, select *Instrument / Target controls*.
4. Select the *GPS Search On* check box.
5. Set the *3D* check box as required.
 - If *3D* is enabled, a 3D GPS Search position is computed, and the instrument can turn to the point both horizontally and vertically.
 - If *3D* is disabled, the instrument can only turn horizontally to the GPS Search position.
 - If SBAS is available, you can enable *3D* because the GPS heights from a GNSS Compact Flash card should be accurate enough to turn the instrument's vertical angle.
 - If SBAS is **not** available, Trimble recommends that you disable *3D* to prevent incorrect GPS heights from a GNSS Compact Flash card causing inaccurate turning of the vertical angle. It may be preferable to turn horizontally only.

- Set the *Select data source* to *Auxiliary GPS*. If the *Receiver type* is not *Trimble GNSS card*, tap *Aux* to select it.

GPS search is now configured. The [relationship between the GNSS positions and local positions](#) must now be resolved before you can use GPS search.

Enabling GPS search using a generic GNSS receiver

- Start the General Survey software and then establish a robotic connection between the Trimble controller and the Trimble total station.
- From the main menu, select *Instrument / Target controls*.
- Set the *3D* check box as required.
 - If *3D* is enabled, a 3D GPS Search position is computed, and the instrument can turn to the point both horizontally and vertically.
 - If *3D* is disabled, the instrument can only turn horizontally to the GPS Search position.
- Set the *Select data source* to *Auxiliary GPS*. If the *Receiver type* is not *Custom*, tap *Aux*, select *Custom* and then set the controller port as appropriate.

When using Bluetooth wireless technology to connect the controller to a *Custom* auxiliary GNSS receiver, from the Trimble Access menu, tap *Settings / Connect / Bluetooth* and then select the receiver in the *Connect to auxiliary GPS* field. For more information, see [Bluetooth](#).

Resolving the relationship between GNSS positions and local positions

If you have a **fully defined coordinate system**, then an accurate relationship between the GNSS positions and local positions already exists using the coordinate system definition. The software assumes that the total station is set up in terms of the defined projection and datum, and GPS search is ready as soon as the station setup is complete. If your total station is not set up in terms of the defined coordinate system then using GPS search will cause the total station to turn incorrectly.



If you do **not** have a defined coordinate system, you must resolve the relationship between GNSS positions and local positions before GPS Search is ready. Once a station setup is complete, the General Survey software uses the NMEA positions from the GNSS receiver and the angles tracked by the robotic instrument to determine the relationship between the two positioning systems. GPS Search computes the relationship independently of the job's coordinate system settings.

To determine the relationship, make sure that the GNSS receiver has a clear view of the sky and then, with the instrument locked to the prism, move the rod around the instrument until the relationship between the GNSS positions and local positions is resolved. A minimum of five positions at least five meters apart and at least ten meters from the instrument are required. If the geometry and GNSS positional accuracy is poor, you need more than five positions to resolve the relationship. Poor GNSS positional accuracy may result in an inaccurate relationship being computed.

When GPS Search is ready, the message *GPS Search ready* appears in the status line, and the target icon displays a satellite icon above the prism .

Notes



- To view the GNSS status, tap *GPS* on the *Target controls* screen. Alternatively, from the *GNSS status* screen, tap and hold on the target icon.

If you are going into a bad GNSS environment for an extended period of time, tap  to stop new positions being added into the GPS Search solution. Tap  to start adding points into the GPS Search solution again.

- When GPS Search has good data, it can detect bad data and exclude it from its computations. However, if there are more bad positions than good positions, it is difficult for GPS Search to detect and exclude bad positions. Too much bad data in the computations may prevent GPS Search from becoming ready. If this occurs, move to a better GNSS environment and then tap *Reset* to restart the GPS Search.
- If you perform a calibration or change the coordinate system settings, the existing relationship between the GNSS positions and local positions is lost and must be recomputed.

Using GPS search

GPS search is used automatically when you perform a search for the target. If GPS Search is ready, the instrument turns to the GPS Search position. With a good GNSS position, for example from a Trimble R8 receiver with an RTK fixed solution, and when snap is enabled, the instrument should snap to the target immediately. If the instrument does not snap immediately, it performs a search before locking to the target.

When using GPS Search with a Trimble Survey Grade receiver, a cross indicates the position of the GNSS receiver. When using any other receiver and a GNSS position is available, a satellite icon appears in the map. If a GPS Search solution is available, a black satellite icon appears . If a GPS Search solution is not available, a red satellite icon appears . To turn to the GNSS position in a conventional survey, make sure that there is nothing selected in the map and then tap and hold briefly in the map. From the menu that appears, select *Turn to GNSS* to turn the instrument horizontally to the GNSS position.

Tap *Search* in the *Joystick* screen to perform a normal search even when GPS Search is ready. Use this when you need to search for a target without using the GPS Search position, such as searching for a backsight target.

To perform a GPS-aided search from the *Joystick* screen, tap .

Note - As soon as the instrument locks on to the target, the *Joystick* screen closes.

To perform a standard search throughout the General Survey software, pause GPS Search at any time.

Interrupted target measurement

Configure *Interrupted target measurement* settings in the *Target controls* screen.

Select this option if the measurement is likely to be interrupted, for example, when measuring in traffic. The instrument continues to measure to the target, even if there are prism obstructions, up to the *Interrupt timeout* value.

During an automated measurement, if the instrument fails within the *Interrupt timeout* period the instrument will move back to the target and attempt the measurement again.

Use this option when:

- performing a station setup plus
- performing a resection
- measuring rounds

Notes

- *Interrupted target measurement is available only when using instrument firmware version R12.3.39 or later.*
- *Target interrupted measurement is optimized for instruments with a DR Plus EDM.*

Video

Instruments that have Trimble VISION technology are equipped with a built-in camera. This enables you to:

- See the telescope's field of view on the controller screen, eliminating the need to look through the telescope
- Control the instrument movement by *Tap-and-move*
- Capture images
- View features from multiple sources in 3D, overlaid on the video screen
- Measure with DR more easily
- Verify that all required measurements have been taken
- Document important visual information, for example site conditions

The camera is not coaxial with the telescope. Therefore:

- The General Survey software corrects for this offset when a distance is received from the instrument.
- When there is no distance returned from the instrument (for example, in Standard mode, or in Tracking mode with no target), there could be a vertical offset of up to 38 mm between the crosshair shown on the video screen and the crosshair viewed through the telescope. This offset is most noticeable at close range. The General Survey software uses the last measured distance to calculate the offset correction. If no measurement has been taken, a distance of infinity is assumed.
- When there is no current distance from the instrument the inner crosshair is not drawn.

When connected to an instrument with a camera, do one of the following to access the video screen:

- From the main menu, tap *Instrument / Video*.
- Tap the Instrument functions icon and then tap *Video* in the *Instrument functions* screen.

Notes

- *Video is not available when the General Survey software is connected through a serial cable connection.*
- *Because of the resolution of the video image, there may be a difference of up to one pixel between the crosshair in the video image and the crosshair viewed through the telescope. This difference can be seen with all overlaid data.*
- *Snapshots taken between 3°36' (4 gon) and the zenith will not be directly matched to the point data in the RealWorks Survey software.*

For more details, see:

[Data overlay](#)

[Tap-and-move](#)

[Capturing images](#)

[Video toolbar](#)

[Video settings](#)

[Video softkeys](#)

[Camera options](#)

Data overlay

Features from the job are overlaid onto the video image to show a graphical representation of features in 3D. Overlaid features can come from multiple sources:

- points, lines, and arcs from the current job database
- points from linked jobs, linked CSV files, and from [map files](#) (for example, DXF and SHP files)
- coded features from feature libraries

Notes

- *Features can be displayed only if they are defined in 3D. This requires that a full 3D station setup has been completed, with a station elevation and instrument height defined.*
- *Features displayed in the video screen cannot be selected.*
- *Only grid coordinates are displayed. If you have not defined a projection, only points stored as grid coordinates appear.*
- *If there is a point with the same name as another point in the database, the point with the higher search class is displayed. For more information about how the General Survey software uses search classes, see [Database search rules](#).*

Tap-and-move

Tap-and-move allows you to control the instrument. Tap in the video screen to turn the instrument to that location.

Notes

- *When you are working in the video screen, the up, down, left, and right arrow keys are in [Joystick](#) mode and can be used to turn the instrument.*

- *Tap-and-move is affected by the offset from the non-coaxial camera.*

Capturing images

You can capture the image displayed in the video frame of the scanning window.

- Captured images are saved as JPG files to the **<jobname> Files** folder.
- Captured images can be viewed in *Review job*.
- Image options are controlled by [Video settings](#).

Images can be automatically captured when a measurement from the video window is taken.

To easily attach images from an instrument to a point using the attribute field, see [Linking media files](#).

Tip - Use the [Panorama](#) function to automatically capture multiple images for a defined scan frame.







To ensure that images can be correctly matched to point data in the Trimble Business Center or RealWorks Survey software, always complete a [station setup](#) before you capture any images. Otherwise, there is no orientation information stored with the image.

Note - *If tracking is turned on and the instrument is locked to a prism, do not move the prism while the image is being captured. Otherwise, you could capture the wrong image, and the wrong orientation information will be stored with that image.*

To transfer JPEG files from the Trimble CU in the docking station to the office computer, use the USB-to-Hirose cable. You cannot use the DB9-to-Hirose serial cable to transfer JPG files.

Video toolbar

The Video toolbar buttons are as follows:

Button / Softkey	Function
	Zoom in/out to the maximum zoom level/full extents.
	Zoom in/out one zoom level at a time.
	Tap Snapshot to capture an image.
	Tap Camera options to define image settings. See Camera options .
	Tap Show and then tap: <ul style="list-style-type: none"> • Settings to configure display and photo properties. • Filter to select which features are displayed. Tap  to filter points by <i>Point name</i>, <i>Code</i>, <i>Descriptions</i> (if enabled) and <i>Note</i>. For more information, see Filtering data using wildcard searching. • Scans to select which scans are displayed.

Video settings

The *Display* group controls whether items are displayed in the video or map screen. Select:

- *Names* to display name labels next to points in the map.
- *Codes* to display code labels next to points in the map.
- *Elevations* controls the option to display elevations in the video screen.
- *Overlay color* controls the color used to display points and elevations.

Enable *Autostore snapshot* to automatically store captured images.

If *Autostore snapshot* is not selected, the image is displayed before storing, enabling you to *Draw* on the image.

Enable *Snapshot on measure* to automatically capture a snapshot after a measurement is taken from the video screen

Enable *Annotate snapshot* to add an information panel and crosshairs for the measured position to the image.

The *Photo properties* group controls the settings for images captured using the instrument. The available settings depend on the connected instrument.

Set the file name, image size, and compression.

File names are automatically incremented from the start file name. The image captured is always the same size as the video display on screen. Not all image sizes are available at all zoom levels. The higher the quality of the image, the larger the file size of the captured image.

Video softkeys

Use the video softkeys to configure the following additional functions:

Softkey	Function
<i>Options</i>	Enable <i>Auto measure</i> to automatically start a measurement when you press the measure key.

Camera options

This topic describes the options for the camera in an instrument that has Trimble VISION technology.

To access the camera options, tap  in the *Video* screen or the *Scanning* screen.

The available options depend on the instrument connected.

- [Trimble VX Spatial Station or S6/S8 total station with VISION technology](#)
- [Trimble S5/S7/S9 total station](#)

Options for the Trimble VX Spatial Station or S6/S8 total station with VISION technology

Brightness

Brightness controls the brightness of the video image on the controller screen as well as captured images. Increase the brightness to make shadows and mid-tones in an image brighter without affecting highlights.

Contrast

Contrast controls the contrast of the video image on the controller screen as well as captured images. Increase the contrast to make images more vibrant; decrease contrast to make images duller.

White balance

White balance controls the light levels in the video image on the controller screen as well as captured images.

Select the setting(s) most suitable to the lighting conditions at your setup:

- When outdoors, in bright settings, select *Daylight*.
- When under artificial light, select *Incandescent*.
- When under fluorescent lighting, select *Fluorescent*.

Options for the S5/S7/S9 total station

White balance

In most cases you can get accurate color in your images by selecting *Auto* and then selecting the most appropriate *Scene mode*. However, if the image has a tint to it, select *Manual*, manually adjust the white balance and then recapture the image. Tap *Set white balance* to store the new white balance settings.

Scene mode

Select the *Scene mode* appropriate for the light conditions at your location:

- When outdoors, in bright settings, select *Bright sunlight* or *Daylight*.
- When under artificial light, select *Halogen*.
- When under fluorescent lighting, select *Warm fluorescent* or *Cold fluorescent*.

Set white balance

Tap *Set white balance* to adapt the white balance to the contents of the current frame. This is used as the white balance until you tap *Set white balance* again.

Note - This setting assumes that the view framed in the video screen has an average color of mid-grey. If that is not the case, Trimble recommends positioning a mid-grey card in front of the

camera and focusing the camera on the card before you tap *Set white balance*.

Spot exposure

When capturing an image with even lighting, Trimble recommends setting *Spot exposure* to *Off* so that the light levels in the entire frame are measured, and the exposure is averaged without giving special weighting to a particular area so that the bright and dark areas of the image are balanced.

When aiming the instrument, or for images with uneven lighting conditions, Trimble recommends enabling spot exposure. When enabled, only the area within the center rectangle is used to measure the light levels. The software divides the central rectangle into four windows of equal size and compares those windows to adjust the exposure of the image.

If you select:

- *Average*, the software calculates the average exposure across the four windows within the central rectangle and then uses that to adjust the exposure of the image.
- *Illuminate*, the software selects the darkest of the four windows and adjusts the exposure of the image so that the darkest window is correctly exposed.
For example, use *Illuminate* when capturing an image of a dark house or roof corner in front of a bright sky. The dark house or roof corner is illuminated.
- *Darken*, the software selects the lightest of the four windows and adjusts the exposure of the image so that the lightest window is correctly exposed.
For example, use *Darken* when capturing an image through a window. The objects through the glass are darkened so that they are more visible.

Data output

Two data output formats are supported:

[GDM data output](#)

[Pseudo NMEA GGA output](#)

For information on outputting NMEA from the GNSS receiver see [NMEA outputs](#).

GDM data output

Use GDM data output option to stream...	from these controllers...	to this instrument
Horizontal angle, Vertical angle, Slope distance, Northing, Easting, Elevation, Date, Time	Trimble CU	Trimble VX Spatial Station or Trimble S Series total station or directly from the COM port of the
	TSC2	
	TSC3	Trimble VX Spatial Station or Trimble S Series total station
	Trimble tablet	

To enable GDM streamed data output:

1. From the main menu, select *Instrument / Data output*.
2. Set the *Streamed data* to either *After measurement* or *Continuous*.
3. Select either *GDM HA VA SD* or *GDM user defined* as the *Streamed format*.
If the *Streamed format* is set to *User defined*, configure the GDM labels.
4. If necessary, configure the *Port details*.
If the *Streamed format* is set to *User defined*, configure the *Time output*.

GDM data output remains enabled while the *Data output* form is open. To access other functions in the General Survey software and leave *Data output* running, use *Switch to* or *Menu*.

To stop data output, tap *Stop*, or close the *Data output* form.

Supported labels

Label	Text	Description
7	HA	Horizontal angle
8	VA	Vertical angle
9	SD	Slope distance
37	N	Northing
38	E	Easting
39	ELE	Elevation
51	Date	Date
52	Time	Time

Notes

- If streamed output is on and no new distance is available, the HA and VA labels are sent rather than the user defined labels.
- If streamed output is on, and the instrument is in Autolock mode but it is not locked onto a target, GDM data is not sent. When using Autolock mode, the instrument must be locked onto a target for any GDM data to be sent.
- The angle and distance units match the General Survey system settings.
- To set the number of decimal places for the horizontal angle and vertical angle records, select *Jobs / Properties of job*. Tap the *Units* button and then select the appropriate option in the *Angle display field*.
- The northing, easting, and elevation units match the General Survey system setting.
- Before the system can output northing, easting, and elevation, you must complete a station setup. Otherwise, the system outputs 0, 0, 0.
- To stream data from the COM port on the Trimble CU robotic holder, or the Trimble VX Spatial Station or Trimble S Series total station, you must connect the cable **before** you open the *Data output* form. Otherwise, the COM port is not available.

Pseudo NMEA GGA output

This output format is based on the NMEA (National Marine Electronics Association) standard for interfacing marine electronic devices. A modified version of one of the NMEA 'sentences', the GGA sentence, is being generated.

Use Pseudo NMEA GGA data output to stream...	from these controllers...	to this instrument
Northing, Easting, Elevation (rather than the standard latitude, longitude, and altitude values)	Trimble CU	Trimble VX Spatial Station or Trimble S Series total station or directly from the COM port of the
	TSC2	
	TSC3	
	Trimble tablet	

To enable Pseudo NMEA GGA streamed data output:

1. From the main menu, select *Instrument / Data output*.
2. Set the *Streamed data* to either *After measurement* or *Continuous*.
3. Select *Pseudo NMEA GGA* as the *Streamed format*.
4. If necessary, configure the *Port details*.

Pseudo NMEA GGA data output remains enabled while the *Data output* form is open. To access other functions in the General Survey software and leave *Data output* running, use *Switch to or Menu*.

To stop data output, tap *Stop*, or close the *Data output* form.

A typical example of an output record is:

```
$GPGGA,023128.00,832518.67,N,452487.66,E,1,05,1.0,37.48,M,0.0,M,0.0,0001*49
```

The fields in this record are as follows:

Field	Description
\$GPGGA	Data type identifier for the NMEA sentence
023128.00	Time field - UTC time of position fix (hhmmss.ss)
832518.67	North coordinate in the currently set units output to 2 decimal places
N	Fixed text indicating preceding value was the north coordinate
452487.66	East coordinate in the currently set units output to 2 decimal places
E	Fixed text indicating preceding value was the east coordinate
1	Fix quality (always output as 1 = GPS fix)
05	Number of satellites (not applicable in this case and always output as 05)
1.0	HDOP value (not applicable in this case and always output as 1.0)
37.48	Elevation value in the currently set units output to 2 decimal places
M	Units identifier for elevation value (also indicates units for north and east values). M or F indicating Meters or Feet (US Survey Feet or International Feet both use the F output

Field	Description
	as there is no means of indicating which feet unit)
0.0	Geoidal separation (always output as 0.0 since an elevation value is being output)
M	Units identifier for the geoidal separation (always output as M)
0.0	Time in seconds since last DGPS update (not applicable in this case and always output as 0.0)
0001	DGPS base station ID (not applicable in this case and always output as 0001)
*49	Record checksum value with * separator.

If there are no coordinate values available for output in the Pseudo NMEA GGA sentence, the north, east, and elevation comma-separated fields in the record will be empty.

Radio settings

These settings are used with a conventional instrument in robotic mode.

The internal radio settings are set when General Survey connects to the instrument. The remote radio settings are set later when you start the rover survey.

You must configure the radio settings to the same values on the instrument and on the rover radios.

Note - *General Survey cannot communicate with the total station when the instrument's onboard programs are being used. After using the onboard programs, select Exit from the Setup menu to return to the Waiting for connection menu.*

Tip - For fast access to configure the Radio settings, tap the instrument icon in the status bar, and then tap and hold on the Start Robotic icon.

Radio channel

To avoid conflicting with another user on the same Radio channel, give your instrument radio and rover radio a unique radio channel.

Network ID

To avoid conflicting with another user on the same Network ID, give your instrument radio and rover radio a unique ID number.

Station and remote address

To avoid conflicting with another user on the same radio channel, give your instrument and radio a unique address. Enter a station and a remote address between 0 and 99.

Configuring radio settings

Configuring the controller to communicate with a Trimble robotic total station

1. From the Trimble Access menu, tap *Settings / Connect / Radio settings*.
2. Configure the *Radio channel* and *Network ID* to the same values as those set on the instrument.
3. Tap *Accept*.

When the controller connects to the instrument using either a cable or Bluetooth technology, the radio settings in the instrument are automatically synchronized to match the controller settings.

Tip - To configure the instrument Radio channel and Network ID without General Survey, select *Radio settings* on the total station through the *Face 2* menu display. For more information, refer to the documentation for your instrument.

Using a controller with an external radio

You can connect a controller to an external radio and then use the external radio to connect to a Trimble VX Spatial Station or Trimble S Series total station. Use:

- [Bluetooth wireless technology](#) to connect the controller to a TDL2.4.
- a serial cable to connect the controller.

To obtain a robotic connection to the Trimble VX Spatial Station or Trimble S Series total station through an external radio you must reconfigure the radio port setting on the controller:

1. From the Trimble Access menu, tap *Settings / Connect / Radio settings*.
2. Tap *Options*, tap *External radio*.
3. If the external radio is a TDL2.4, select *Bluetooth* in the *Controller port* field.
4. Tap *Accept*.
5. Configure the *Radio channel* and *Network ID* to the same values as those set on the instrument.
6. Tap *Accept*.

Notes

- *You cannot interchange the Trimble VX Spatial Station or Trimble S Series total station system radios with Trimble 5600 system radios because the radio technology is incompatible.*
- *In some countries, you must obtain a radio license before using your system on a working site. Make sure that you check the regulations for your country.*

AT360 eBubble options

If the active target has inbuilt tilt sensors and you are performing a conventional survey, an eBubble (electronic bubble) showing tilt information for the target is available. To configure the eBubble tap *Instrument / eBubble options* from the main menu. You can configure the following settings:

Option	Description
eBubble sensitivity	The bubble moves 2mm for the specified sensitivity angle. To decrease sensitivity select a large angle.
Tilt tolerance	Defines the maximum radius that the target can tilt and be considered in tolerance. The allowable range is 0.001m to 1.000m. The tilt distance shown is calculated using the current target height.

Tip - You can also access the *AT360 eBubble options* screen by doing one of the following:

- Tap the Settings icon in the top left corner of the *eBubble* window.
- Tap the *AT360* softkey from the *eBubble options* screen for a different sensor. If you have more than one tilt sensor connected, changing the eBubble settings for one sensor changes the eBubble settings for all connected tilt sensors.

eBubble calibration

To calibrate the eBubble tap the *Calib* softkey and then tap the *Calibrate* button to begin tilt calibration. Level the instrument with the calibrated reference and brace against movement. Tap *Start*. The calibration information is stored in the job.

A well-calibrated eBubble is of vital importance. The accuracy of tilt information used to display the eBubble, and stored with measured points, is totally dependent on the calibration of the tilt sensors inside the active target. Using a poorly-calibrated eBubble will directly degrade the accuracy of the coordinates measured using the eBubble as a level reference. Great care should be taken when you are calibrating the eBubble to ensure the most accurate tilt information is available at all times.

Bubble reference: Calibrate the eBubble against a properly calibrated physical bubble. The accuracy of the eBubble depends totally on the accuracy of the physical bubble used to calibrate it.

Pole stability: When calibrating the eBubble, the pole the active target is on should be as vertical and as stable as possible. In practice this means using at least a tripod to hold the pole as still as possible.

Pole straightness: A bent pole will affect the tilt measured by the sensors in the active target. If you calibrate the eBubble using a bent pole and then change poles, the accuracy of points will be affected. Also, if you calibrate using a straight pole and then change to a bent pole, the target will not be plumb even though the eBubble will say it is, again affecting the accuracy of the measured points.

Abuse: If the active target suffers severe abuse such as a pole drop, you should recalibrate the eBubble.

For more information, refer to the active target documentation.

eBubble display

To display the eBubble, tap the *eBubble* softkey.

Bubble color	Meaning
Green	You are within the defined tilt tolerance.
Red	You are outside the defined tilt tolerance.

Tips

- To move the eBubble window to a new position on the screen, tap and hold on the eBubble and drag to a new position.
- Press **CTRL + L** to show or hide the eBubble from any screen.

Battery status

To view the *Battery status* screen, do one of the following:

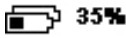
- From the *Instruments* menu, tap *Battery status*.
- Tap the Stacked Battery icon  in the status bar.

The *Battery status* screen shows the status of all batteries in all connected devices, including the controller. The percentage level shown on the Stacked Battery icon matches the lowest battery level shown in the *Battery status* screen.

Note - The status of the TDL2.4 battery is shown only when the TDL2.4 is connected to a Trimble VX Spatial Station or Trimble S Series total station.

For more information, tap the:

- Controller battery icon to view the operating system battery screen
- GNSS battery icon to view the *Receiver status* screen.
- V10 battery icon to view the *V10 settings* screen.

GNSS Survey Instruments

Instrument menu

The *Instrument* menu provides information about the instrument(s) connected to the Trimble controller running the Trimble Access software, and is used to configure the settings for the instrument.

For more information see:

[Conventional Instrument menu](#)

[GNSS Instrument menu](#)

GNSS Instrument menu

If the controller is connected to a GNSS receiver, the GNSS *Instrument* menu is shown. Available options depend on the type of receiver that is connected.

GNSS receivers that can be connected to the controller running Trimble Access are:

- Trimble integrated GNSS surveying systems: R10, R8s, R8, R6, R4, R2
- Trimble modular GNSS surveying systems: R9s, NetR9 Geospatial, R7, R5
- Trimble GeoExplorer Geo7X handheld
- Trimble GeoExplorer GeoXR handheld
- Trimble SPS Series GNSS receivers; SPS585, SPS77x, SPS78x, SPS88x, SPS75x, SPS 85x, SPS985, and SPS985L

Note - *If a conventional instrument is also connected and you are performing an integrated survey, additional items appear in the Instrument menu. For more information, see [Conventional Instrument menu](#).*

For more information on GNSS instrument settings, see the following topics:

[GNSS functions](#)

[Satellites](#)

[Receiver files](#)

[Position](#)

[Receiver status](#)

[GSM status](#)

[Receiver settings](#)
[R10 eBubble options](#)
[Magnetometer calibration](#)
[Navigate to point](#)
[RTK network status](#)
[V10 panorama](#)
[Camera](#)
[Battery status](#)

GNSS instrument functions

To access the *GNSS functions* screen, do one of the following:

- tap the instrument icon on the controller screen
- select *Instrument / GNSS functions* from the General Survey main menu
- press and hold the Trimble key

The *GNSS functions* screen is available for GNSS receivers. Use it to control commonly-used GNSS receiver functions. In *Bluetooth Settings*, you can configure the base and rover receivers separately and then use *GNSS functions* to switch between them. This makes it very easy to connect to and control your base or rover receiver.

The following buttons are available in GNSS functions:

- [Base mode](#)
- [Rover mode](#)
- [Bluetooth](#)
- [Data link](#)
- Start survey
- End survey
- Power down Receiver
- [Satellites](#)
- [Position](#)
- [Navigate to point](#)
- [Import files](#)
- [Receiver status](#)

If the button is not available to select, the function is not applicable to the current mode, or there is no receiver connected for the currently-selected mode.

The *Base mode* and *Rover mode* buttons within *GNSS functions* have different states. If the button is highlighted in yellow, the mode is enabled.

Base mode

When *Base* mode is enabled, auto-connect will attempt to connect to the Trimble GNSS receiver configured in the *Connect to GNSS base* field in the *Bluetooth* settings screen.

If there is no receiver configured there, it will try to connect to a Trimble GNSS receiver on the controller's serial port. The receiver found on the serial port will be treated as the base receiver when the software is in *Base* mode.

In *Base* mode the *Start survey* and *End survey* buttons in *GNSS functions* start or end a base survey using the Survey Style that you selected when you tapped either of those buttons.

The auto-connect icon shows if the software is in *Base* mode.

Rover mode

When *Rover Mode* is enabled, auto-connect will attempt to connect to the Trimble GNSS receiver configured in the *Connect to GNSS rover* field in the *Bluetooth* settings screen.

If there is no receiver configured there, it will try to connect to a Trimble GNSS receiver on the controller's serial port. The receiver found on the serial port will be treated as the rover receiver when the software is in *Rover* mode.

In *Rover* mode the *Start survey* and *End survey* buttons in *GNSS functions* start or end a rover survey using the Survey Style that you selected when you tapped either of those buttons.

The auto-connect icon shows if the software is in *Rover* mode.

Data link

You can use this button to connect to and configure the radio you are using for your RTK data link.

When the instrument is in *Rover* mode, tap the *Data link* button to go to the *Rover data link* settings screen.

When the instrument is in *Base* mode, tap the *Data link* button to go to the *Base data link* settings screen.

If the softkey displays *>Rover* or *>Base* tap to switch to the appropriate mode and then tap *Connect*.

In this screen, when a survey is not running, you can select the type of RTK radio you are using and then tap *Connect* (if it is available) to connect to and configure the communication settings in the radio. You can review and set the radio frequency, baud rate, and other settings if they are available to change in the radio device that the instrument is connected to.

You cannot edit Survey Style settings in this screen. If you start a survey with a *different* type of radio set in the Survey Style, the system uses that radio - not the radio that you set in *GNSS functions*.

If there is an RTK survey running, the radio screen shows the radio currently in use, and you may not be able to connect to an external radio.

For more information, see [Configuring a radio data link](#).

Satellites

To see information about the satellites currently being tracked by the receiver, tap the satellite icon on the status bar or select *Instrument / Satellites* from the main menu.

A satellite is identified by the space vehicle (SV) number.

- GPS satellite numbers are prefixed with a "G".
- GLONASS satellite numbers are prefixed with an "R".
- Galileo satellite numbers are prefixed with an "E".
- QZSS satellite numbers are prefixed with a "J".
- BeiDou satellite numbers are prefixed with a "C".
- OmniSTAR satellites are identified as "OS".
- RTX satellites are identified as "RTX".

The satellite positions can be represented graphically with the sky plot or textually in a list.

Sky plot

To see a sky plot, tap *Plot*.

- Tap *Sun* to see the plot oriented towards the sun.
- Tap *North* to see the plot oriented towards north.
- The outside circle represents the horizon or 0° elevation.
- The inner, solid green, circle represents the elevation mask setting.
- The SV numbers on the diagram are placed in the position of that particular satellite.
- Satellites that are tracked but not used in the position solution appear in blue.
- The zenith (90° elevation) is the center of the circle.

Notes

- Tap the SV number to view more information about that specific satellite.
- An unhealthy satellite is shown in red.

Satellite list

To see the list of satellites, tap *List*.

- In the list of satellites, each horizontal line of data relates to one satellite.
- Azimuth (*Az*) and elevation (*Elev*) define a satellite's position in the sky.
- The arrow displayed next to the elevation indicates whether the elevation is increasing or decreasing.
- The signal-to-noise ratios (SNR) indicate the strength of the respective satellite signals. The greater the number, the better the signal.
- If a signal is not being tracked, then a dashed line (----) appears in the appropriate column.
- The check mark on the left of the screen indicates whether that satellite is in the current solution, as shown in the following table.

Situation	What a check mark indicates
No survey is running	Satellite is being used in the current position solution
RTK survey is active	Satellite is common to the base and rover receivers
Postprocessed survey is running	Satellite for which one or more epochs of data have been collected

- To see more information about a particular satellite, tap the appropriate line.

You can also select the following options:

- To stop the receiver tracking a satellite, tap the satellite to display the satellite information and then tap *Disable*.

Note - If you disable a satellite, it remains disabled until you enable it again. Even when the receiver is switched off, it stores that a satellite is disabled.

- To change the **elevation** mask and the **PDOP** mask for the current survey, tap *Options*.
- To enable SBAS outside of a survey, tap *Options* and then select Enable SBAS.
- In a real-time survey, tap *Base* to see which satellites are being tracked by the base receiver. No values appear in the *Az* and *Elev* columns, as this information is not included in the correction message broadcast by the base.
- In a postprocessed survey, the *L1* softkey appears in the *Satellites* dialog. Tap *L1* to display a list of cycles tracked on the L1 frequency for each satellite.

The value in the *CntL1* column is the number of cycles on the L1 frequency that have been tracked continuously for that satellite. The value in the *TotL1* column is the total number of cycles that have been tracked for that satellite since the start of the survey.

- With a dual-frequency receiver, the *L2* softkey appears in the *Satellites* dialog. Tap *L2* to display a list of cycles tracked on the L2 frequency for each satellite.

The *SNR* softkey appears. Tap *SNR* to return to the original screen and view information about the signal-to-noise ratio for each satellite.

Enabling and disabling SBAS satellites

When you start a survey configured to use SBAS with Trimble Access, the appropriate satellites are enabled in the receiver so that they can be tracked. To use an alternative SBAS satellite, disable the satellite(s) that you do not want to use, and enable the satellite that you want the receiver to track. To do this:

1. Start the survey with the SBAS enabled style.
2. Tap the satellite icon.
3. Tap *Info* and then enter the PRN number of the satellite that you want to enable or disable.
4. Tap *Enable* or *Disable*.

The SBAS satellites remain enabled or disabled until the next time that you start a new survey.

Receiver files

If the controller is connected to a receiver that supports this function, you can transfer files to and from the Trimble controller to the receiver.

The *Import from receiver* option is available when a Trimble GNSS receiver is in use. Use it to delete files in the connected receiver, or to copy files from the connected receiver to the controller.

Notes

- To access the External memory of a receiver that supports both Internal and External memory, tap on the Parent folder from the Internal directory and then tap on External.
- You cannot undelete deleted receiver files.

The *Export to receiver* option is available when a Trimble GNSS receiver is in use that has a compact flash card inserted. Use it to copy files from the controller to the connected receiver.

You can transfer files only to and from the **current project folder** on the controller. To transfer files to or from **another** project folder, open a job in the required project folder (which thereby changes that one to the **current** project folder) and then transfer the files. Alternatively, use Windows Explorer to copy the files to another folder.

Transferring files from the receiver to the controller

1. From the main menu, select *Instrument / Receiver files / Import from receiver*.

The list that appears shows all files stored in the receiver.

2. Tap the file(s) to transfer. A check mark appears next to the selected files.

Note - To see more information about a file, highlight the file name and tap *Info*. To delete a file, highlight the file name and tap *Delete*. To select all files within the current directory, tap *All*.

3. Tap *Import*. The *Copy file to Trimble Controller* screen appears.
4. Tap *Start*.

Transferring files from the controller to the receiver

1. From the main menu, select *Instrument / Receiver files / Export to receiver*.

The list that appears shows all files in the current project folder on the controller.

2. Tap the file(s) to transfer. A check mark appears next to the selected files.
3. Tap *Export*.
4. Tap *Start*.

Position

If the controller is connected to a GNSS / GPS receiver, or you are using a controller with internal GPS, you can view your current position.

Tap *Store* to store the current position in the job database.

Note - When using a controller with internal GPS, a connected GNSS receiver is always used in preference to the internal GPS.

A projection and datum transformation must be defined to view grid coordinates.

If the antenna height is defined, the software calculates the position of the pole tip. To also view the position of the base antenna, tap *Base*.

Tap *Options* to find out if the position is shown as WGS-84, local, grid, grid (local), ECEF (WGS84), [station and offset](#), or USNG/MGRS.

If a GNSS receiver with an in-built tilt sensor is being used, the current tilt distance is also shown.

The Position screen does not apply the tilt correction to positions; the position displayed is the uncorrected position.

Receiver status

To view the power and memory status of the connected GNSS receiver, the GPS time, and the GPS week, select *Instrument / Receiver status* from the main menu.

GSM status

The GSM status is available only with Receiver Internal modems.



Note - The GSM status is not available when the receiver's internal modem is connected to the Internet.

To view the GSM signal strength and available network operators when using the Trimble Internal GSM module, select *Instrument / GSM Status* from the Instrument menu.

The *GSM status* screen shows the status reported by the modem at the time you select *GSM status*, or when you tap *Refresh*.

If you set a PIN on the SIM card and the modem is in a locked state, you must key in the SIM PIN to be sent to the modem. The PIN is not stored, but the receiver remains unlocked with the correct PIN until you turn off the power and then turn it on again.

Note - After three attempts to unlock the SIM card using an incorrect PIN, the SIM card is blocked, except for emergency calls. You are prompted to enter a PUK (Personal Unblocking Key) code. If you do not know the PUK for your modem, contact the supplier of the modem SIM card. After ten unsuccessful attempts to enter the PUK, the SIM card is invalidated and is no longer operable. When this occurs, you must replace the card.

Network operator shows the current network operator. The home network icon  shows that the current network operator is the home network for the active SIM card. The roaming network icon  shows that the current network operator is not the home network.

Select network shows a list of network operators obtained from the mobile network.

When you enter the GSM status menu or when you tap *Refresh*, the modem queries the mobile network for the list of network operators. Poor reception can result in fewer networks being returned by the network when the modem queries it for the list.

Some SIM cards are locked to specific networks. If you select a network operator that is forbidden by the host network, the system shows one of the following messages: **Failed to select network operator** or **Network not allowed - emergency calls only**.

Select *Automatic* to put the modem into 'automatic' network selection mode. The modem then searches for all network operators and tries to connect to the most appropriate network operator, which may or may not be the home network.

If you select any other network operator from *Select network*, the modem goes into 'manual' selection mode and tries to connect with the selected network operator.

If you select *GSM status* or tap *Refresh* while in 'manual' mode, the modem searches only for the last manually-selected network operator.

For a list of network operators that you can connect to, contact your subscribed network operator.

Signal strength shows the GSM signal strength.

Firmware version shows the modem firmware version.

Receiver settings

To view the configuration of the connected GNSS receiver, select *Receiver settings* from the main menu. Alternatively, tap and hold on the receiver icon in the status bar to view the *Receiver settings*.

eBubble options

If your receiver has inbuilt tilt sensors an eBubble (electronic bubble) is available.

- To configure the eBubble tap *eBubble*.
- To calibrate the eBubble tap *eBubble* and then *Calib*.
- To display the eBubble, tap *eBubble* and then *eBubble*.

Wi-Fi

You can use the Trimble Access software to configure the Wi-Fi settings in a receiver that is Wi-Fi enabled. To do this:

1. Select *Instruments / Receiver settings* and tap *Wi-Fi*.

Note - The *Wi-Fi* softkey is only displayed when the receiver is connected but not running a survey.

2. Select the *Mode*. Three modes are supported:

- Off
- Access point: Use this mode to enable the receiver as an access point so that many clients can connect to it.
- Client: Use this mode to enable the receiver to connect to an existing network.

Notes

- The mode will only be updated in the receiver after the receiver has been restarted.
- Longer battery life can be achieved by setting the *Mode* to *Off*.

3. Configure the settings as required. Refer to the receiver manual for further details.

Tip - Use the arrow buttons to change the display order of the networks.

R10 eBubble options

If your receiver has inbuilt tilt sensors and you are performing a GNSS survey, an eBubble (electronic bubble) showing tilt information for the receiver is available. To configure the eBubble tap *Instrument / eBubble options* from the main menu. You can configure the following settings:

Option	Description
eBubble sensitivity	The bubble moves 2mm for the specified sensitivity angle. To decrease sensitivity select a large angle.
Tilt tolerance	Defines the maximum radius that the receiver can tilt and be considered in tolerance. The allowable range is 0.001m to 1.000m. The tilt distance shown is calculated using the current antenna height.
Tilt calibration status	Current tilt sensor calibration status.
Calibration expires in	The date that the current calibration will expire. The eBubble must then be recalibrated.
Calibration age limit	Displays the time period between calibrations. At the end of the time period the software will prompt you to recalibrate the eBubble. To edit the default value tap the pop-up arrow.
eBubble response	Controls the eBubble's responsiveness to movement.

Tip - You can also access the *R10 eBubble options* screen by doing one of the following:

- Tap the Settings icon in the top left corner of the *eBubble* window.
- Tap and hold the receiver icon in the status bar to view the *Receiver settings* screen and then tap *eBubble*.
- Tap the *R10* softkey from the *eBubble options* screen for a different sensor. If you have more than one tilt sensor connected, changing the eBubble settings for one sensor changes the eBubble settings for all connected tilt sensors.

eBubble calibration

To calibrate the eBubble tap the *Calib* softkey and then tap the *Calibrate* button to begin tilt calibration. Level the instrument with the calibrated reference and brace against movement. Tap *OK*.

WARNING - If you tap *Cancel* before the calibration is complete the previous calibration is lost and the eBubble will not be calibrated.

Notes

- *The receiver does not need to be tracking satellites to calibrate the eBubble. However, because the calibration time is stored in the receiver, it is important that the controller has the correct time and timezone.*

- *The details of the calibration including the Tilt calibration status is stored in the job and can be reviewed from Jobs / Review job.*

A well-calibrated eBubble is of vital importance. The accuracy of tilt information used to display the eBubble, and stored with measured points, is totally dependent on the calibration of the tilt sensors inside the GNSS receiver. Using a poorly-calibrated eBubble will directly degrade the accuracy of the coordinates measured using the eBubble as a level reference. Great care should be taken when you are calibrating the eBubble to ensure the most accurate tilt information is available at all times.

Bubble reference: Calibrate the eBubble against a properly calibrated physical bubble. The accuracy of the eBubble depends totally on the accuracy of the physical bubble used to calibrate it.

Pole stability: When calibrating the eBubble, the pole the GNSS receiver is on should be as vertical and as stable as possible. In practice this means using at least a bipod to hold the pole as still as possible.

Pole straightness: A bent pole will affect the tilt measured by the sensors in the GNSS receiver. If you calibrate the eBubble using a bent pole and then change poles, the accuracy of points will be affected. Also, if you calibrate using a straight pole and then change to a bent pole, the GNSS will not be plumb even though the eBubble will say it is, again affecting the accuracy of the measured points.

Temperature: The tilt sensors are affected by the temperature of the unit. The GNSS receiver will expire the calibration if the current temperature inside the receiver is more than 30 degrees Celsius different to when the current calibration was performed. This forces you to recalibrate the eBubble.

Abuse: If the GNSS receiver suffers severe abuse such as a pole drop, you should recalibrate the eBubble.

See the receiver manual for further information.

eBubble display

To display the eBubble, tap the *eBubble* softkey.

Bubble color	Meaning
Green	You are within the defined tilt tolerance.
Red	You are outside the defined tilt tolerance.

Tips

- To move the eBubble window to a new position on the screen, tap and hold on the eBubble and drag to a new position.
- Press **CTRL + L** to show or hide the eBubble from any screen.

See also: [Tilt auto measure](#) and [Tilt warnings](#).

Magnetometer calibration

Note - This topic describes calibrating the magnetometer in the R10 receiver. For information on calibrating the magnetometer in the V10, see [V10 Magnetometer Calibration](#).

A well-calibrated magnetometer is of vital importance when surveying [compensated points](#). The magnetometer calculates the direction of the tilt of the antenna. Information from the magnetometer is reflected in the precision estimates for the point. Using a poorly calibrated magnetometer will directly degrade the accuracy of the coordinates measured when surveying a compensated point.

WARNING - The performance of the magnetometer is affected by nearby metal objects (for example, vehicles or heavy machinery) or objects that generate magnetic fields (for example, high voltage overhead or underground power lines). Always calibrate the magnetometer away from sources of magnetic disturbance. In practice this usually means outdoors.

Note - Calibrating the magnetometer near sources of magnetic disturbance **does not** "correct" for the interference caused by these objects.

Calibrating the magnetometer

1. In the *Instrument* screen, tap *eBubble options* and then tap *Calib*.
2. Detach the receiver from the pole.
3. To perform the magnetometer calibration, tap *Calibrate*.
4. Tap *Start* and then rotate the receiver as shown on-screen for a minimum of 12 different orientations, until calibration is complete.
5. Reattach the receiver to the pole.
6. To perform the magnetometer alignment, use the eBubble to make sure the pole is as vertical as possible and then tap *Calibrate*.
7. Tap *Start* and then rotate the receiver slowly and smoothly around its vertical axis until calibration is complete.

Notes

- For best horizontal accuracy, Trimble recommends you calibrate the tilt sensor and the magnetometer in the receiver each time you replace the battery.
- Calibrating the tilt sensor invalidates the magnetometer alignment. Always re-perform the magnetometer alignment after calibrating the tilt sensor.
- The magnetometer is less sensitive to temperature than the tilt sensor. However, if the current temperature inside the receiver is more than 30 degrees Celsius different to when the tilt sensor calibration was performed, the tilt sensor calibration is invalidated. This in turn invalidates the magnetometer alignment.
- If the GNSS receiver suffers severe abuse such as a pole drop, you should recalibrate the tilt sensor and magnetometer.
- If you tap *Cancel* before the calibration is complete, the existing magnetometer calibration is used.

- *The receiver does not need to be tracking satellites to calibrate the magnetometer. However, because the calibration time is stored in the receiver, it is important that the controller has the correct time and time zone.*
- *The details of the calibration are stored in the job and can be reviewed from Jobs / Review job.*

Navigate to point

If the controller is connected to a GNSS receiver, or you are using a controller with internal GPS, you can navigate to a point. Using GNSS / GPS, you can navigate to a point without a survey running.

If you are running a conventional survey, you can also navigate to a point. During the conventional survey, if the controller is connected to a GNSS receiver, or you are using a controller with internal GPS, you can continue navigating to a point if you lose lock. Tap the *GNSS* button and then navigate to the point.

When you start the *Navigate to point* function, it uses the settings in the last GNSS survey style that you used.

CAUTION - To ensure that internal GPS is available on a TSC3 or Trimble Slate controller, the GPS format must be set to *NMEA* (this is the default format). If the GPS format is set to *SiRF Binary*, you cannot use the internal GPS. To set the format press the *Windows* button to access the *Start* menu and then tap *SatViewer*. In the *GPS* tab, make sure that the *NMEA* option is selected.

Notes

- *No configuration is required for the Geo7X/GeoXR controller or a Trimble tablet.*
- *When using a controller with internal GPS, a connected GNSS receiver is always used in preference to the internal GPS.*
- *If you are using a GNSS receiver that can track SBAS signals, when the radio link is down you can use SBAS positions instead of autonomous positions. To use SBAS positions, set the *Satellite differential* field in the survey style to *SBAS*.*

Navigating to a point

1. Do one of the following:
 - From the map, select the point you want to navigate to. Then tap and hold on the map and select *Navigate to point* from the shortcut menu.
 - Select *Instrument / Navigate to point* from the main menu.
2. Fill in the other fields as required and then tap *Start*. The graphical display screen appears.
3. Use the arrow to navigate to the point, which is shown as a cross. When you are close to the point, the arrow disappears and a bull's-eye symbol appears. A grid also appears and changes scale as you move closer to the target.
4. When you are on the point, the bull's-eye symbol covers the cross.
5. Mark the point if required.

Tips

- Tap *Position* and then *Store* to store a point.
- If navigating with a Trimble controller that has an internal compass, you can use the internal compass to aid navigation. See [Compass](#) for further details.

RTK network status

When you perform a real-time survey and the reference station or network server that you receive base station data from supports status messaging, the *RTK network status* menu option appears. The screen for this menu option shows the reported status of the reference station server, the options the reference station supports (such as *RTK on Demand*), and also enables you to configure notification and storage of the status messages in the current job.

If you select the *Popup new Reference Station* messages check box, messages from the reference station or network server pop up on the screen.

If you select the *Store Reference Station* messages check box, messages from the reference station or network server are stored in the current job database.

Battery status

To view the *Battery status* screen, do one of the following:

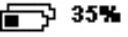
- From the *Instruments* menu, tap *Battery status*.
- Tap the Stacked Battery icon  in the status bar.

The *Battery status* screen shows the status of all batteries in all connected devices, including the controller. The percentage level shown on the Stacked Battery icon matches the lowest battery level shown in the *Battery status* screen.

Note - The status of the TDL2.4 battery is shown only when the TDL2.4 is connected to a Trimble VX Spatial Station or Trimble S Series total station.

For more information, tap the:

- Controller battery icon to view the operating system battery screen
- GNSS battery icon to view the [Receiver status](#) screen.
- V10 battery icon to view the [V10 settings](#) screen.

Coordinate System

Coordinate system

A coordinate system consists of a projection and datum transformation and, sometimes, additional horizontal and vertical adjustments.

When you create a job, select a coordinate system by one of the following methods:

- [Scale factor only](#)
- Select from library
- Key in parameters
- [No projection/ no datum](#)
- [Broadcast RTCM](#)
- [SnakeGrid](#) (available only when the [Advanced Geodetic](#) option is enabled)

If you need to perform a GNSS site calibration, or change the parameters manually after selecting the coordinate system, select *Jobs / Properties of job / Coord. sys.*

When editing coordinate system details for a job that uses a coordinate system selected from the library, Trimble Access modifies the coordinate system name to indicate that some user preferences have been defined. When the coordinate system is:

- Selected from the library:
 - The *Coordinate system* field displays "Zonename (SystemName)".
 - Changing the geoid model or project height does not change the name of the coordinate system.
 - Editing any projection or datum parameters changes the coordinate system name to "Local site". To remove these changes and revert to the original name of the coordinate system, you must reselect it from the library. If you overlay a GNSS site calibration over this "Local site" the name of the coordinate system remains "Local site".
 - Completing a GNSS site calibration changes the coordinate system name to "Zonename (Site)". If you disable the site calibration (by keying in parameters) the coordinate system name reverts to the original name.
 - Editing any horizontal adjustment or vertical adjustment parameters changes the coordinate system name to "Zonename (Site)". If you remove these changes, the coordinate system name reverts to the original name.

- Defined using *No projection/no datum*, completing a GNSS site calibration changes the coordinate system name to "Local site".
- Defined using *Key in parameters*, the coordinate system name is "Local site".

If you modify the coordinate system by calibration or by manually changing the parameters, you must do so before you compute offsets or intersection points, or stake out points in the local coordinate system.

To set up a [ground coordinate system](#) for the job, choose the *Select from library* or *Key in parameters* option.

To customize the coordinate systems available on the General Survey software, use the Coordinate System Manager software. For more information see [Customizing the coordinate system database](#).

Customizing the coordinate system database

You can customize the coordinate system database used by the General Survey software. This enables you to:

- Reduce the number of coordinate systems available in the General Survey software so that it includes only the ones you need.
- Customize existing coordinate systems definitions or add new coordinate system definitions.
- Include GNSS site calibrations in the coordinate system library.

You must use the Coordinate System Manager software to modify the Coordinate System Database (CSD) and then transfer the modified database to the [System files] folder on the Trimble controller. When a [custom.csd] file exists in the [System files] folder, the General Survey software uses the custom.csd database instead of the coordinate system database built into the General Survey software.

Note -The Coordinate System Manager software is installed at the same time as your Trimble Office software, for example, Trimble Business Center.

Tips for using the Coordinate System Manager software

- To make multiple selections, press **CTRL** or **SHIFT**.
- To hide records, right click the selection and then select *Hide*.
- To display hidden records, select *View / Hidden Records*. Hidden records are displayed with a dark red icon.
- To unhide hidden records, right click hidden record(s) and then clear the *Hide* check box.

For more information, see the Coordinate System Manager Help.

There are a number of ways you can use the Coordinate System Manager software to customize the coordinate systems. From the following options, choose the one that best suits your needs.

Reducing a coordinate system library to one or more coordinate systems, zones, and sites

1. Run the Coordinate System Manager software on your office computer.
2. Do one or more of the following to hide the required element:

- Coordinate system: In the left pane of the *Coordinate Systems* tab, select the coordinate system(s) that you do not want, right click and then select *Hide*.
 - Zone: In the left pane of the *Coordinate Systems* tab, select a coordinate system, from the right pane, select the Zone(s) you do not want, right click and then select *Hide*.
 - Site: From the *Sites* tab, right click the site(s) you do not want and then select *Hide*.
3. Select *File / Save As*.
 4. Name the file [custom.csd] and then click **Save**.

By default, the file is saved in [Program Files\Common Files\Trimble\GeoData] with the extension *.csd.

Exporting only user-defined coordinate systems

1. Run the Coordinate System Manager software on your office computer.
2. Select *File / Export*.
3. Select *User-defined records only* and then click **OK**.
4. Name the file [custom] and then click **Save**.

By default, the file is saved in [Program Files\Common Files\Trimble\GeoData] with the extension *.csw.

Note - If a GNSS site calibration has been saved using your Trimble Office software, a site with the assigned name is added to the *Sites* tab and a Site group is created in the *Coordinate Systems* tab, if required. When you create a customized coordinate system that includes sites saved by the Trimble Office software, include those sites created in the *Sites* tab. The Site group in the *Coordinate Systems* tab contains the coordinate system details **referenced** by the sites saved in the *Sites* tab, but the calibration details are **only** stored in the site in the *Sites* tab.

Transferring customized coordinate systems

You can transfer the file to the controller using the Trimble Data Transfer utility or Windows Mobile Device Center. The file must be called [custom.csd] for the General Survey software to access it.

A file transferred by the Data Transfer utility is automatically renamed and saved to the [System files] folder. If you transfer the file using Windows Mobile Device Center, you must copy the file to the [System files] folder and then rename the file to [custom.csd].

For more information on transferring a file from a Trimble controller to an office computer, refer to the Trimble Access *Help*.

When the *Open* dialog appears, select *CSD Files (*.csd)* or *CSD Files (*.csw)* from the *Files of type* list.

Selecting a custom site in General Survey software

1. From the main menu, select *Jobs / New job*.
2. Enter the *Job name*.
3. In the *Properties* group, tap the *Coord sys* button.
4. Choose *Select from library* and then tap *Next*, if required.
5. If this is a new custom.csd file, a warning appears. Tap *OK* to accept.

6. In the *System* field, select *[User sites]*.
7. In the *Site* field, select the required site.
8. If required, select a geoid model.
9. To return to the *New job* dialog, tap *Store*.
10. In the *New job* dialog, tap *Accept* to save the new job.

Scale factor only

Use this projection type when you are doing a conventional-instrument only survey with a local scale factor. This option is useful for areas that use a local scale factor to reduce distances to the local coordinate system.

To choose a scale factor only projection:

1. Create a new job.
2. Select *Scale factor only* from the *Select coordinate system* menu.
3. Enter a value in the *Scale* field and then tap *Store*.

Projection

A projection is used to transform local geodetic coordinates into local grid coordinates.

Note -Enter an appropriate default height value for the General Survey software to correctly calculate a sea level correction and then apply it to the grid coordinate.

GNSS coordinates are relative to the WGS-84 ellipsoid. To work in local grid coordinates, you must specify a projection and datum transformation.

You can specify a projection:

- when a job is created and you have to choose a coordinate system (select from a list, or key in)
- during a survey (you calculate values by performing a calibration)
- in the Trimble Business Center software, when the data is transferred.

Do not change the coordinate system or calibration after you have staked out points, or computed offset or intersection points.

If a projection and datum transformation are specified, you can reduce any discrepancies between the WGS-84 coordinates and the local grid coordinates by performing a site calibration.

Ground coordinate system

If you require coordinates to be at ground level instead of projection level, use a ground coordinate system. When you select a ground coordinate system, grid distances equal ground distances.

To set up a ground coordinate system, when you create a job:

1. Specify a coordinate system by choosing the *Select from library*, or *Key in parameters* option.
2. To use ground coordinates with the selected coordinate system, tap the Page down button, and then from the *Coordinates* field, do one of the following:
 - To key in a scale factor, select *Ground (Keyed in scale factor)*.
 - To let the General Survey software calculate the scale factor, select *Ground (Calculated scale factor)*. Enter values in the *Project Location* group to compute the scale factor.

The computed scale factor allows for the projection scale factor at the Project Location to ensure that the combined factor (point scale factor multiplied by the sea level factor) at the Project Location equals 1.

The General Survey software applies the ground scale factor to the projection.

3. To add offsets to the coordinates, enter a value in the *False northing offset* and *False easting offset* fields as required.

Note -When working with a ground coordinate system the reported ground distance may not be the same as the reported grid distance. The reported ground distance is simply the ellipsoid distance corrected for the average height above the ellipsoid. However the grid distance is computed between the ground coordinates of the points, and is therefore based on a coordinate system that provides a combined scale factor of 1 at the Project Location.

Note -Use offsets to differentiate ground coordinates from unmodified grid coordinates.

Project height

The project height can be defined as part of the coordinate system definition when creating a new job. To find it, select *Jobs / Properties of job* for a coordinate system in either the *Library* or *Key in projection* dialogs.

If a point has no elevation, the General Survey software uses the project height in Cogo calculations. If you combine GNSS and 2D conventional observations, set the *Project height* field to approximate the height of the site. This height is used with 2D points to calculate grid and ellipsoid distances from measured ground distances.

In 2D surveys where a projection has been defined, enter a value for the project height that approximates the height of the site. You need this value to reduce measured ground distances to ellipsoid distance, and to compute coordinates.

If you edit the project height (or any other local site parameter) after calibrating, the calibration becomes invalid and must be reapplied.

No projection / no datum

To select a coordinate system with an undefined projection and datum, when you create a job:

1. Tap the *Coord. sys* button and select *No projection/no datum*.

2. Set the *Coordinates* field to *Ground*, and enter a value (average site height) in the *Project height* field to use ground coordinates after a site calibration. Alternatively, set the *Coordinates* field to *Grid*.
3. Select the *Use geoid model* check box, and select a geoid model to calculate a Geoid/Inclined plane vertical adjustment after a site calibration.

Tip - To automatically complete the *Project height* field, tap *Here* to use the current autonomous height derived by the GNSS receiver, or tap *Point* to use the height of a point in the job or in a linked file.

Any points measured using GNSS are displayed only as WGS84 coordinates. Any points measured using a conventional instrument are displayed with null (?) coordinates.

The General Survey software performs a calibration that calculates a Transverse Mercator projection and a Molodensky three-parameter datum transformation, using the supplied control points. The project height is used to compute a scale factor for the projection so that ground coordinates can be computed at elevation.

Broadcast RTCM

A Network RTK provider can configure a VRS network to broadcast RTCM messages that include some of the coordinate system definition parameters. When the *Broadcast format* is set to RTCM RTK, and the broadcast datum definition messages are broadcast by the VRS network, General Survey can use this to provide the datum and ellipsoid definition for a job.

When creating a new job to use with Broadcast RTCM, select *Broadcast RTCM* from the Select coordinate system screen, along with the appropriate projection parameters.

General Survey supports a subset of the RTCM transformation parameters, as shown below:

Transformation message	Details	Supported
1021	Helmert/Abridged Molodensky (Control)	Yes
1022	Molodensky-Badekas Transformation (Control)	Yes
1023	Ellipsoidal Datum Shift Grid Residual	Yes
1024	Plane Grid Residual	No
1025	Projection	No
1026	Projection Lambert Conformal Conic Two Parallel	No
1027	Projection Oblique Mercator	No
1028	Local Transformation	No

The RCTM broadcast message must contain either the 1021 or the 1022 control message. This defines what other messages will be present. All other messages are optional.

Datum shift grid values are broadcast at fixed time intervals for a grid surrounding the area you are working in. The size of the grid that is broadcast depends on the density of the source grid data. To perform coordinate system transformations, the grid file that is built by General Survey must include shift grids covering the location of points you are transforming. When you move to a new

location, a new set of datum shift grid values is broadcast and there may be a slight delay until the appropriate values are received from the VRS network server.

The broadcast transformation messages include a unique identifier for the broadcast parameters. If the broadcast parameters change, the identifier changes, and the General Survey creates a new grid file to store the new datum grid shift values.

If the broadcast RTCM transformation changes, General Survey shows the following message: *The broadcast coordinate system has changed. Continue?*

- If you select *Yes*, the system creates a new grid file, or, if it exists, uses another grid file that matches the newly broadcast transformation. If you change grid files, the new grid file may not cover the same area as the old grid file, so General Survey may not be able to transform points where there are 'holes' in the grid file.
- If you select *No*, you cannot continue surveying. Create a new job and start the survey again. If you need access to data in the old job, link that job.

If you copy a job that is defined to use a Broadcast RTCM datum onto a different controller, and you do not copy the grid file, or if you delete the grid file on the controller, then General Survey does not have the appropriate grid file to perform the transformation and grid coordinates are not available. Similarly, if the controller with the copied job already has a grid file, but the grid file does not cover the area of the copied job, then coordinate transformation is not possible.

Notes

- *When a General Survey job with broadcast RTCM data is exported as a DC file, the GNSS observations are output as grid positions.*
- *A General Survey job with broadcast RTCM data cannot be imported to Trimble Business Center software version 2.0 or earlier.*

SnakeGrid

SnakeGrid is a coordinate system with minimal scale factor and height distortion, even when projects extend for many hundreds of kilometers.

A job using a SnakeGrid coordinate system must use a custom SnakeGrid parameter file. These files are obtained through a licensing arrangement from the UCL Department of Civil, Environmental and Geomatic Engineering. Each SnakeGrid parameter file is customized for a specific project alignment envelope. Go to www.SnakeGrid.org for details.

Note - *The SnakeGrid parameter file name must be named SnakeXXXXX.dat, where "XXXXX" can be anything you want.*

To choose a SnakeGrid projection:

1. Create a new job.
2. From the *Select coordinate system* menu, select *SnakeGrid*.

Note - *The SnakeGrid option is available only when the [Advanced Geodetic](#) option is enabled*

3. Select the appropriate SnakeGrid parameter file.

SnakeGrid parameter files must be placed in the **Trimble Data\System Files** folder on the device.

Horizontal adjustment

A horizontal adjustment is a least-squares adjustment that is applied to minimize the differences between transformed grid coordinates and local control points.

Horizontal and vertical adjustments are calculated if you perform a calibration when a projection and datum transformation are defined.

Trimble recommends that you use a minimum of four control points to compute a horizontal and vertical adjustment.

Alternatively, you can key in horizontal adjustment parameters when you start a new job.

Vertical adjustment

This is a least-squares adjustment that is applied to convert (ellipsoid) heights to elevation. It is computed when you do a calibration. A minimum of one point is required to compute the adjustment. If more points are used, an inclined plane adjustment can be calculated.

If you have a geoid model selected, you can choose to use only the geoid model, or to use the geoid model and do an inclined plane adjustment. Trimble recommends that you use a geoid model to obtain more accurate orthometric heights from your GNSS measurements.

You can specify the type of vertical adjustment when you create a job. Set this parameter when you choose the coordinate system. You can also key in the parameters when you create a job.

To change the parameters for the current job, from the main menu select *Jobs / Properties of job*, tap *Coord sys* and then select *Key in parameters / Vertical adjustment*.

Note - When the Projection is set to Scale factor only, the Datum transformation, Horizontal adjustment, and Vertical adjustment options are not available. Select a non Scale factor only projection to access the other parameters.

Coordinate systems

Before starting a GNSS survey, decide which coordinate system to use. This topic discusses some things to consider when making this decision.

[Choosing a coordinate system for a conventional survey](#)

[Choosing a coordinate system for a GNSS survey](#)

[Choosing a coordinate system for a broadcast RTCM survey](#)

[GNSS coordinate system](#)

[Local coordinate systems](#)

[Calibration](#)

[Using a datum grid file](#)

[Using a geoid model](#)

[Trimble geoid models – WGS-84 versus local ellipsoid-based geoid models](#)

Working with ground coordinates

If you intend to combine conventional observations with GNSS measurements, read the whole of this topic. To make only conventional observations, see [Choosing a coordinate system for a conventional survey](#).

Choosing a coordinate system for a conventional survey

When surveying using conventional equipment, it is important to choose a suitable coordinate system.

For example, if a job is to combine GNSS measurements with conventional observations, choose a coordinate system that lets you view GNSS observations as grid points. This means that you must define a projection and a datum transformation. For more information, see [Creating a job](#).

Note - *You can complete the field work for a combined survey without defining a projection and a datum transformation, but you will not be able to view the GNSS observations as grid coordinates.*

If you want to combine GNSS measurements with two-dimensional conventional observations, specify a project height for the job. For more information, see [Project height](#).

If a job is to contain conventional observations only, select one of the following when you create the job:

- A typical coordinate system and zone that provide mapping plane coordinates. For example, State Plane coordinates.
- Scale factor only.

In a conventional survey, measurements are made at ground level. To compute coordinates for these measurements, observations are reduced to grid level. The specified scale factor is applied to measured distances to reduce them from ground to grid.

The *Scale factor only* option is useful for areas that use a local scale factor to reduce distances to grid.

Tip - If you are not sure what coordinate system to use, select the *Scale factor only* projection and enter a scale factor of 1.000.

Choosing a coordinate system for a GNSS survey

When you create a new job, the General Survey software prompts you to define the coordinate system you are using. You can select a system from the library, key in the parameters, select *Scale factor only*, or select *No projection / no datum* transformation. For more information, see [Creating a job](#).

The most rigorous coordinate system consists of four parts:

- datum transformation
- map projection
- horizontal adjustment
- vertical adjustment

Note - *To conduct a real-time survey in terms of local grid coordinates, define the datum transformation and map projection before starting the survey.*

Tip - In the *Coordinate view* field, select *Local* to display local geodetic coordinates. Select *Grid* to display local grid coordinates.

When WGS84 coordinates are transformed onto the local ellipsoid, using a datum transformation, local geodetic coordinates result. Local geodetic coordinates are transformed into local grid coordinates using the map projection. The result is Northing and Easting coordinates on the local grid. If a horizontal adjustment is defined, it is applied next, followed by the vertical adjustment.

Choosing a coordinate system for a broadcast RTCM survey

When you create a new job, the General Survey software prompts you to define the coordinate system you are using. When surveying with VRS and the *RTCM broadcast* includes coordinate system parameters, create the job with the Datum set to *Broadcast RTCM*. To do this, select *Broadcast RTCM* from the *Select coordinate system* screen and then select the appropriate coordinate system to use from the available library definitions.

You can also use *Key in parameters* to enter your own specific projection definition. When you key in the parameters for the projection definition, make sure that the Datum transformation is set to *Broadcast RTCM*. To do this, tap the *Datum trans* button and then select *Broadcast RTCM*, before you save the coordinate system definition.

Coordinate system types

GNSS coordinate system

GNSS measurements are referenced to the 1984 World Geodetic System reference ellipsoid, known as WGS84. However, for most survey tasks, results in terms of WGS84 have little value. It is better to display and store results in terms of a local coordinate system. Before you start a survey, choose a coordinate system. Depending on the requirements of the survey, you can choose to give the results in the national coordinate system, a local coordinate grid system, or as local geodetic coordinates.

When you have chosen a coordinate system, search your survey archives for any horizontal and vertical control points in that coordinate system that are in the area to be surveyed. You can use these to calibrate a GNSS survey. For more information, see [Calibration](#).

Local coordinate systems

A local coordinate system simply transforms measurements from a curved surface (the earth) onto a flat surface (a map or plan). Four important elements constitute a local coordinate system:

- local datum
- datum transformation
- map projection
- calibration (horizontal and vertical adjustments)

When you survey using GNSS, consider each of these.

Local datum

Because an exact model of the earth's surface cannot be created mathematically, localized ellipsoids (mathematical surfaces) have been derived to best represent specific areas. These ellipsoids are sometimes referred to as local datums. NAD83, GRS80, and AGD66 are examples of local datums.

Datum transformation

GNSS is based on the WGS84 ellipsoid, which is sized and positioned to best represent the entire earth.

To survey in a local coordinate system, the WGS84 GNSS positions must first be transformed onto the local ellipsoid using a datum transformation. Three types of datum transformation are commonly used. Alternatively, you can choose not to use a transformation at all.

The datum transformations are as follows:

- three-parameter - This assumes that the rotational axis of the local datum is parallel with the rotational axis of WGS84. The three-parameter transformation involves three simple translations in X, Y, and Z. The three-parameter transformation that the General Survey software uses is a Molodensky transformation, so there may also be a change in ellipsoid radius and flattening.

Note - Positions on a local datum are commonly called "local geodetic coordinates". The General Survey software abbreviates this to "Local".

- Seven-parameter - This is the most complex transformation. It applies translations **and** rotations in X, Y, and Z, as well as a scale factor.
- Datum grid - This uses a gridded data set of standard datum shifts. By interpolation, it provides an estimated value for a datum transformation at any point on that grid. The accuracy of a datum grid depends on the accuracy of the gridded data set it uses. For more information, see [Using a datum grid file](#).

Map projection

Local geodetic coordinates are transformed into local grid coordinates using a map projection (a mathematical model). Transverse Mercator and Lambert are examples of common map projections.

Note - Positions on a map projection are commonly called "local grid coordinates". The General Survey software abbreviates this to "Grid".

Horizontal and vertical adjustments

If published datum transformation parameters are used, slight discrepancies can exist between local control and GNSS-derived coordinates. These discrepancies can be reduced using minor adjustments. The General Survey software calculates these adjustments when you use the *Site calibration* function. They are called horizontal and vertical adjustments.

Calibration

Calibration is the process of adjusting projected (grid) coordinates to fit the local control. You can key in a calibration, or let the General Survey software calculate it. You should calculate and apply a

calibration before:

- staking out points
- computing offset or intersection points

The rest of this section describes how to perform a calibration using the General Survey software. To key in a calibration, see [Creating a job](#).

Why calibrations are needed

If you calibrate a project and then survey in real time, the General Survey software gives real-time solutions in terms of the local coordinate system and control points.

Operations that require calibration

Note - Perform a calibration at any time, but always complete the calibration **before** staking out any points, or computing offset or intersection points.

If no datum and no projection are defined, you can only stake out lines and points that have WGS84 coordinates. Displayed bearings and distances are in terms of WGS84.

Specify a projection before staking out arcs, roads, and DTMs. The General Survey software does not assume that WGS84 is the local ellipsoid, so you must also define a datum.

Without a datum transformation, you can only start a real-time base survey with a WGS84 point.

For information on how to perform a calibration, see [Calibration](#).

The following diagram shows the order of calculations performed when a calibration is calculated.

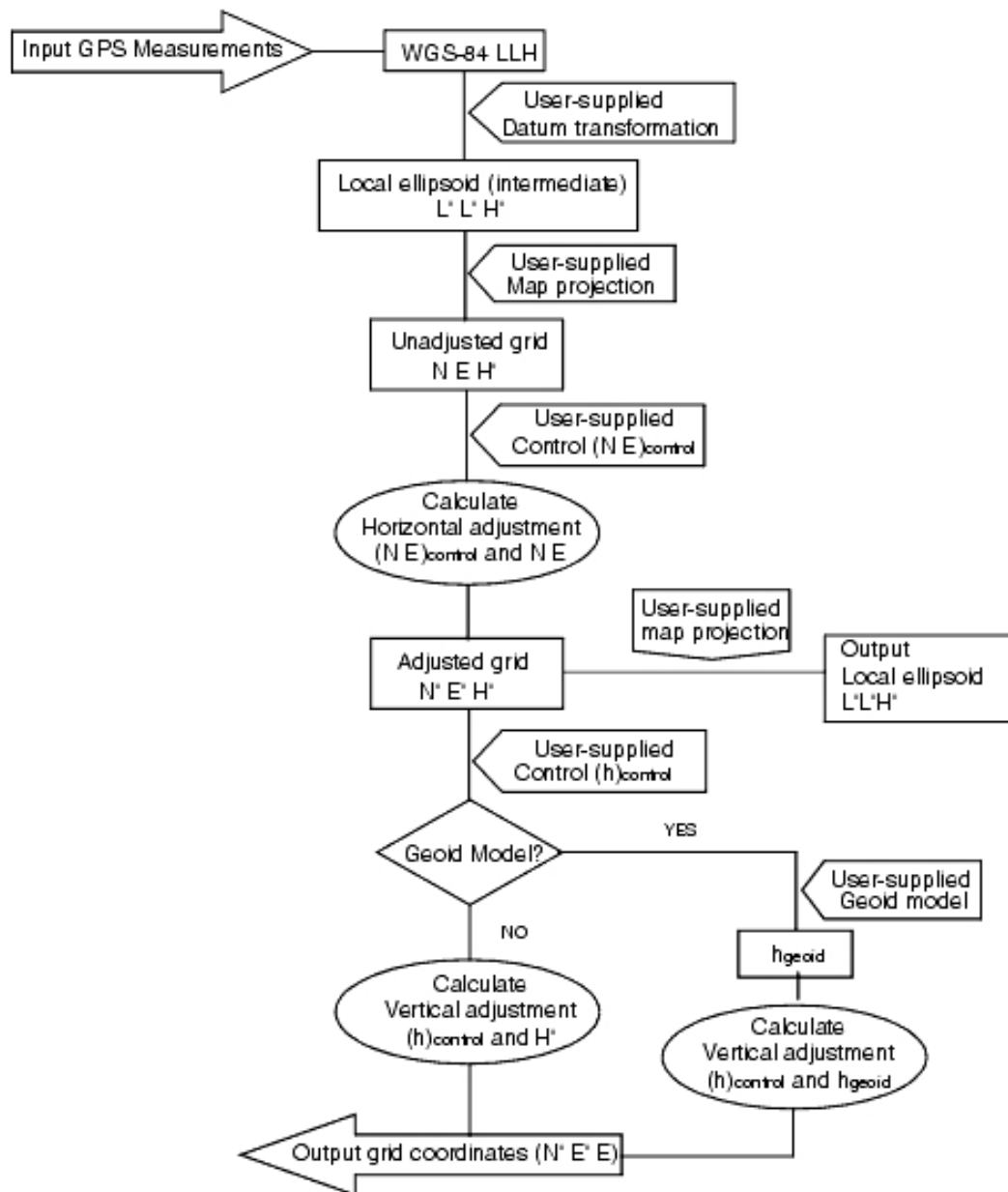

Performing calibration calculations

Use the General Survey software system to perform a calibration in one of two ways. Each method results in the computation of different components, but the overall result is the same if enough reliable control points (coordinates in your local system) are used. The two methods are:

- If you use published datum transformation parameters and map projection details when creating a job, and if you provide enough control points, the General Survey software performs a calibration that computes horizontal and vertical adjustments. Horizontal control

points allow scale error anomalies in the map projection to be removed. Vertical control allows local ellipsoid heights to be transformed into useful orthometric heights.

Tip - Always use published parameters if they exist.

- If you do not know the map projection and datum transformation parameters when creating the job and defining the local coordinate system, specify *No projection / no datum*.

Then specify whether grid or ground coordinates are required after a site calibration. When ground coordinates are required, you must specify the project height. In this case, the General Survey software performs a calibration that calculates a Transverse Mercator projection and a Molodensky three-parameter datum transformation using the supplied control points. The project height is used to compute a ground scale factor for the projection so that ground coordinates are computed at that height.

The following table shows the output of a calibration when various data is supplied.

Projection	Datum transformation	Calibration output
Yes	Yes	Horizontal and vertical adjustment
Yes	No	Datum transformation, horizontal and vertical adjustment
No	Yes	Transverse Mercator projection, horizontal and vertical adjustment
No	No	Transverse Mercator projection, zero datum transformation, horizontal and vertical adjustment

Local control for calibration

Trimble recommends that you observe and use a minimum of four local control points for the calibration calculation. For best results, local control points should be evenly distributed over the job area as well as extending beyond the perimeter of the site (assuming that the control is free of errors).

Tip - Apply the same principles as you would when placing control for photogrammetric jobs. Make sure that the local control points are evenly distributed to the extent of the job area.

Copying calibrations

You can copy a calibration from a previous job if the new job is completely encompassed by that initial calibration. If a portion of the new job lies outside the initial project area, introduce additional control to cover the unknown area. Survey these new points and compute a new calibration. Use this as the calibration for the job.

Tip - To copy the calibration from an existing job to a new job, make sure that the **current** job you want to copy has the calibration that you require in the new job. Then create the new job. A new job uses the default values from the previous job. Use the softkeys on the Job properties screen to change the defaults.

Using a datum grid file

A datum grid transformation uses interpolative methods to estimate the value of the datum transformation at any point in the area covered by the datum grid files. Two gridded datum files are

required for this interpolation—a latitude datum grid file and a longitude datum grid file. When you export a datum grid using the Trimble Geomatics Office software, the two datum grid files associated with the current project are combined into a single file for use in the General Survey software.

Note - If you use the Canadian NTv2 datum grid please note the data is provided on an "as is" basis. The Department of Natural Resources Canada (NRCan) makes no guarantees, representations, or warranties respecting the data.

Selecting a datum grid file

To select a datum grid file when creating a job, do one of the following:

- Select a coordinate system from the library provided in the General Survey software. Select the *Use datum grid* check box. In the *Datum grid* field, select the file that you want to use.
- Key in the coordinate system parameters. Select *Datum transformation* and set the *Type* field to Datum grid. In the *Datum grid* field, select the file that you want to use.

Note - The U.S. State Plane 1927 and the U.S. State Plane 1983 coordinate systems in the General Survey software use three-parameter transformations.

To select a datum grid file for use in the current job:

1. From the main menu, select *Jobs / Properties of job / Coord. Sys.*
2. Do one of the following:
 - If *Key in parameters* is selected, select *Next*. Select *Datum transformation* and set the *Type* field to Datum grid. In the *Datum grid* field, select the file that you want to use.
 - If *Select coordinate system* is selected, select *Next*. Select the *Use datum grid* check box. In the *Datum grid* field, select the file that you want to use.

The semi-major axis and flattening values for the selected datum grid file are displayed. These details overwrite any already provided by a specified projection.

Using a geoid model

The geoid is a surface of constant gravitational potential that approximates mean sea level. A geoid model or Geoid Grid file (*.ggf) is a table of geoid-ellipsoid separations that is used with the GNSS ellipsoid height observations to provide an estimate of elevation.

The geoid-ellipsoid separation value (N) is obtained from the geoid model and is subtracted from the ellipsoid height (H) for a particular point. The elevation (h) of the point above mean sea level (the geoid) is the result. This is illustrated in the following diagram.

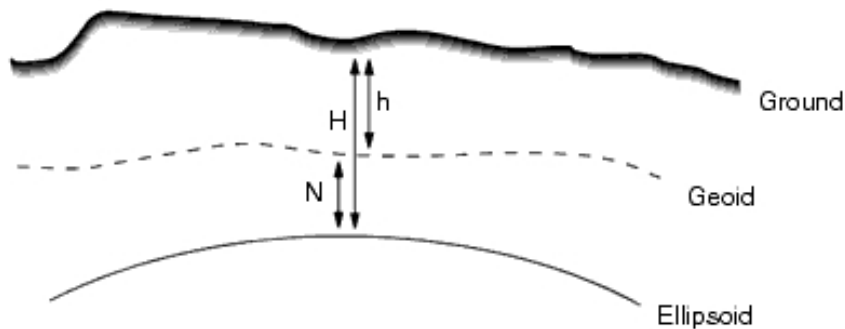

Note - For correct results, the ellipsoid height (H) must be based on the WGS-84 ellipsoid.

When you select geoid model as the vertical adjustment type, the General Survey software takes the geoid-ellipsoid separations from the geoid file chosen, and uses them to display elevations on the screen.

The benefit of this function is that you can display elevations without having to calibrate on elevation benchmarks. This is useful when local control or benchmarks are not available, as it makes it possible to work "on the ground" rather than on the ellipsoid.

Note - If you are using a geoid model in a Trimble Business Center project, make sure you transfer that geoid file (or the relevant part of it) when transferring the job into a Trimble controller.

Selecting a geoid file

To select a geoid file when creating a job, do one of the following:

- Select a coordinate system from the library provided in the General Survey software. Select the *Use geoid model* check box. In the *Geoid model* field, select the file to be used.
- Key in the coordinate system parameters. Select *Vertical adjustment* and set the *Type* field to *Geoid model* or *Geoid/Inclined plane* as required. (Select *Geoid/Inclined plane* if you intend to key in the inclined plane adjustment parameters.)

To select a geoid file for the current job:

1. From the main menu, select *Jobs / Properties of job / Coord. Sys.*
2. Do one of the following:
 - If the *Key in parameters* screen is selected, select *Next*. Select *Vertical adjustment* and set the *Type* field to *Geoid model* or *Geoid/Inclined plane* as required. (If you intend to key in the inclined plane adjustment parameters, select *Geoid/Inclined plane*.)
 - If the *Select coordinate system* screen is selected, select *Next*. Select the *Use geoid model* check box. In the *Geoid model* field, select the file to be used.

CAUTION - Traditionally, geoid models are based on global WGS-84 and, before Trimble Access System version 2011.00, were always treated as global WGS-84 based geoid models even when they might have been based on local ellipsoid geoid models. Trimble geoid models are now applied with respect to the interpolation method set in the geoid file, enabling both global WGS-84 and local ellipsoid based geoid models to be supported. For more information, see [Trimble geoid models – WGS-84 versus local ellipsoid-based geoid models](#).

Working with ground coordinates

If you need coordinates to be at ground level instead of projection level (for example, in areas of high elevation), use a ground coordinate system.

When you select a ground coordinate system, grid distances equal ground distances.

Setting up a ground coordinate system

When you set up a ground coordinate system in a General Survey job, the software applies a ground scale factor to the coordinate system projection definition.

To set up a ground coordinate system when creating a job:

1. Define the coordinate system for the job. Do one of the following:
 - Choose the *Select from library* option to select a coordinate system from the library provided in the General Survey software. Tap *Next*.
 - Choose the *Key in parameters* option to key in the coordinate system parameters. Tap *Next* and then select *Projection*.
2. In the *Coordinates* field, choose an option to define the ground scale factor.
Additional fields appear below the *Coordinates* field.
3. If you select the *Ground (keyed in scale factor)* option, enter a value in the *Ground scale factor* field.
4. In the *Project location* group, enter values in the fields as required. Alternatively, do one of the following:
 - Tap *Here* to enter the current autonomous position derived by the GNSS receiver. The autonomous position is displayed in terms of WGS-84.
 - Tap *Point* and then select a point from in the job or in a linked file to use the coordinates of that position.

Note - The *Point* softkey is not available until there are positions in the job. When creating a new job, you must create the job, then link files to the job or measure a new point, and then return to the Job properties and edit the coordinate system settings. The *Point* softkey is now available.

The project height is used with 2D points to reduce ground distances in Cogo calculations. For more information, see [Project height](#). If you select the *Ground (calculated scale factor)* option, the fields are used to calculate the ground scale factor. When the fields are completed, the computed ground scale factor is displayed in the *Ground scale factor* field.

5. To add offsets to the coordinates, enter a value in the *False northing offset* and *False easting offset* field, as required.

Note - Use offsets to differentiate ground coordinates from unmodified grid coordinates.

To configure a ground coordinate system for the current job:

1. From the main menu, select *Jobs / Properties of job / Coord. Sys*.
2. Do one of the following:
 - If the *Key in parameters* screen is selected, tap *Next* and then select *Projection*. Select an option from the *Coordinates* field. Complete the fields below as required.

- If the *Select coordinate system* screen is selected, tap *Next*. Select an option from the *Coordinates* field and then complete the fields below as required.

Trimble geoid models – WGS-84 versus local ellipsoid-based geoid models

CAUTION - Geoid models are traditionally based on global WGS-84, and were previously always treated as global WGS-84 based geoid models even when they might have been based on local ellipsoid geoid models. Trimble geoid models are now applied with respect to the interpolation method set in the geoid file, enabling both global WGS-84 and local ellipsoid based geoid models to be supported.

To avoid problems because of this change, consider the following items:

Note -The majority of jobs are created using coordinate systems with identity (0,0,0) transformations where the global and local ellipsoid are the same, and in this case, the enhancement of the Geoid model to support both global and local based interpolation models will have no impact.

- All the North American geoid models have their interpolation method set to identify that they are local ellipsoid based models, even though they were previously treated as global WGS-84 based. This means that if you are using datum transformation definitions that are not identity (0,0,0) transformations, elevations derived from the North American geoid models will change. This difference would normally have been corrected with a calibration, and now that the Geoid model is being interpolated differently, it is important to recalibrate jobs that fall into this category, as identified below.
- All calibrations with the **three** following attributes must be recomputed to provide the same results:
 - a vertical adjustment **and**
 - a geoid model that is not built on an identity (0,0,0) transformation **and**
 - an interpolation method that is local ellipsoid based
- The existing *EGM96 (Global)* geoid model (*ww15mgh.ggf*) is updated to have its interpolation method changed to indicate that it is a global WGS-84 based model rather than a local ellipsoid based model. Update your geoid model to ensure it is interpolated correctly.
- The existing *OSU91A (Global)* geoid model (*OSU91A.ggf*) is updated to have its interpolation method changed to indicate that it is a global WGS-84 based model rather than a local ellipsoid based model. Update your geoid model to ensure it is interpolated correctly.
- Because Minnesota and Wisconsin County Coordinate System definitions use customized local ellipsoids, you cannot use the standard local ellipsoid based North American Geoid models. Therefore, new Geoid09 sub-grids have been created (*G09-MN.ggf* and *G09-WI.ggf*) and assigned as the default geoid models in the updated definitions for these systems. Upload these new global WGS-84 based sub-grid geoid models to any controller that will be using these coordinate system definitions.
- Any sub-gridded geoid model files that are uploaded to a controller inherit the same interpolation method as the geoid model they were created from. Update sub-grid models

that were created from the existing *EGM96 (Global)* geoid model with sub-grid models created from the new *EGM96 (Global)* geoid model set up as a global WGS-84 based model.

Use the Geoid Model Configuration utility to check the interpolation method in a Trimble geoid model file and change it if necessary. To download the utility, go to www.trimble.com/tbc_ts.asp?Nav=Collection-71 and then click *Downloads* in the navigation panel on the left.

Note - When Trimble Access Installation Manager updates Trimble office products (for example, Business Center, Trimble Geomatics Office and GPS Pathfinder Office), it also updates the geodetic components. You must run Trimble Access Installation Manager on all office computers so that both the field and office software products are using the same geodetic components.

Options softkey

This softkey appears in only some screens. It allows you to change the configuration for the task being performed.

If you make changes using the *Options* softkey, they only apply to the current survey or calculation. The changes do not affect the current Survey Style or the job configuration.

Distance setting options

The computed area varies according to the *Distance* display setting. The following table shows the effect of the distance setting on the area calculated.

Distances setting	Computed area
Ground	At the average ground elevation
Ellipsoid	On the ellipsoid surface
Grid	Directly off the grid coordinates

Traverse options

Use these options to specify how a traverse calculation is adjusted.

Field	Option	What it does
Adjustment method	Compass	Adjusts the traverse by distributing the errors in proportion to the distance between traverse points
	Transit	Adjusts the traverse by distributing the errors in proportion to the northing and easting ordinates of the traverse points
Error distribution		
Angular	Proportional to distance	Distributes the angular error among the angles in the traverse based on the sum of the inverses of the distances between traverse points
	Equal proportions	Distributes the angular error evenly among the angles in the traverse
	None	Does not distribute the angular error

Field	Option	What it does
Elevation	Proportional to distance	Distributes the elevation error in proportion to the distance between traverse points
	Equal proportions	Distributes the elevation error evenly among the traverse points
	None	Does not distribute the elevation error

Note - The *Compass* option is the same as the *Bowditch method of adjustment*.

For information about calculating and adjusting a traverse, see [Traverses](#).

Measure display

Use the *Measure display* field to configure how the observations are displayed on the controller.

See the [Conventional Instrument - Corrections](#) table for a description of the measure display options and the corrections that are applied.

Subdivide pts code

When you subdivide a line or an arc, a number of points are created. Use the *Subdivide pts code* field to specify the code that the new points will be allocated. Choose from the name or the code of the line or arc that is to be subdivided.

Projection grids

Use a projection grid to handle projection types that are not directly supported by the Trimble coordinate system routines. A projection grid file stores local latitude and longitude values that correspond to regular northing/easting positions. Depending on the direction of the conversion, either projection or local latitude/longitude positions are interpolated from the grid data for points within the grid extents.

Use the Coordinate System manager to generate the defined projection grid (*.pjt) file.

For more information, refer to the *Coordinate System Manager Help*.

Use the Data Transfer utility or Windows Mobile Device Center to transfer the *.pjt file to the controller. For more information, refer to the General Survey File Transfer Help, Data Transfer Help or Windows Mobile Device Center Help.

To use the projection grid in General Survey:

1. From the main menu, select *Jobs / New job*.
2. Enter the *Job name*.
3. In the *Properties* group, tap the *Coord sys* button.
4. Select *Key in parameters*, if required, tap *Next*.
5. In the *Key in parameters* dialog, select *Projection*.
6. In the *Type* field, select *Projection grid* from the drop-down list.
7. In the *Projection grid file* field, select the required grid file.

8. If required, select the *Use shift grid* check box.
9. Tap *Accept* twice, to return to the *New job* dialog.
10. In the *New job* dialog, tap *Accept* to save the new job.

Shift grids

Initial projection coordinates are projections that are computed using specified projection routines. Some countries use shift grids to apply corrections to these coordinates. The corrections are generally used to fit the initial coordinates to local distortions in the survey framework, and so cannot be modeled by a simple transformation. You can apply a shift grid to any type of projection definition. Coordinate systems that use shift grids include the Netherlands RD zone, and the United Kingdom OS National Grid zones.

Note -The OS National Grid zones are now treated as a standard Transverse Mercator projection plus shift grid but they used to be handled as a special projection type with separate north and east grid files.

Use the Coordinate System manager to generate a shift grid (*.sgf) file. For more information, refer to the *Coordinate System Manager Help*.

Transfer the shift grid (*.sgf) file to the controller. The file is stored in the [System files] folder. Geoid files and Shift grid files are available on the web from: www.trimble.com/tsc_ts.asp?Nav=Collection-58928.

To apply a shift grid to a [projection definition](#):

1. In the *Projection* dialog, select the *Use shift grid* check box.
2. In the *Shift grid file* field that appears, select the required file from the drop-down list.

Database Search Rules

This topic explains the **database search rules** relevant to the General Survey database:

[Dynamic database](#)

[Search rules](#)

[Exceptions to the search rules](#)

[Linked files and their search rules](#)

[Finding the best point in the database](#)

[Duplicate points and overwriting](#)

[Assigning control class to a point](#)

Note - *If your job does not contain points of the same name, then the search rules are not used.*

Dynamic database

The General Survey software includes a dynamic database. This stores networks of connected vectors during RTK and conventional surveys, making the positions of some points dependent on the positions of others. If you change the coordinates of a point that has dependent vectors (for example, an instrument station, a backsight point, or a GPS base station), this affects the coordinates of all points that depend on it.

Note - *Editing the name of a point that has dependent vectors can also affect the coordinates of points that depend on it. If you change the point name, the following could occur:*

- *positions of other points could become null*
- *if another point with a matching name exists, that one could be used to coordinate the dependent vectors*

The General Survey software uses database search rules to resolve the coordinates of dependent points, based on the new coordinates for a point they depend on. If the coordinates of a point with dependent points move by a certain amount, the dependent points are shifted by the same amount.

When two points of the same name exist, the General Survey software uses search rules to determine the best point.

Search rules

The General Survey software lets multiple points with the same point name (point ID) exist in the same job.

To distinguish between points of the same name and to decide how these points are to be used, the General Survey software applies a set of search rules. When you ask for the coordinates of a point in order to perform a function or calculation, these search rules examine the database according to:

- the order in which the point records were written to the database
- the classification (search class) given to each point

Order in the database

A database search starts at the beginning of the job database and works down to the end of the job, looking for a point with the specified name.

The General Survey software finds the first occurrence of a point of that name. It then searches the rest of the database for points of the same name.

The rules generally followed by the software are:

- If two or more points have the same class and the same name, it uses the first point.
- If two or more points have the same name but different classes, it uses the point of higher class, even if this is not the first occurrence of the point.
- If two or more points (one from the job database and one from an attached linked file) have the same name, the software uses the point in the job database, regardless of the classification of the point in the linked file. For more information, see [Linked files and their search rules](#).

There is one exception to this rule. You can now add points to a stakeout list from the linked file using the *Select from file* option, and the point from the linked file will be used even when the point already exists in the current job.

Search class

The General Survey software gives most **Coordinates** and **Observations** a classification. It uses this classification to determine the relative importance of points and observations stored in the job database.

Coordinates have priority over Observations. If a Coordinate and an Observation of the same name have the same class, the Coordinate will be used regardless of its order in the database.

The **Coordinate Classes** are arranged in a descending hierarchy, as follows:

- Control - (the highest class) can only be set when a point is keyed in or transferred.
- Averaged - is given to grid positions stored as a result of an average position computation.
- Adjusted - is given to points that are adjusted in a traverse computation.
- Normal - is given to keyed-in and copied points.

- Construction - is given to all points measured using Fastfix, which are typically used in the computation of another point.
- Deleted - is given to points that have been overwritten, where the original point had the same (or a lower) search class than the new point.

Deleted points are not displayed in point lists and they are not used in calculations. However, they do remain in the database.

Control class

Control class is used in preference to other classes. It can only be set by you. Use control class for points that you want to use in preference to points of the same name in the same job database. For more information, see [Assigning control class to a point](#).

Note - You cannot overwrite a control class point with a measured point, or use a control class point in an average position computation.

In general, if there are multiple observations with the same name, the best point is determined by the point that has the highest classification.

The **Observation Classes** are arranged in a descending hierarchy, as follows:

- Mean Turned Angle (MTA) *, Normal, Backsight, and Stakeout are now all the same classification.
- Construction
- Check
- Deleted

Deleted observations are not displayed in point lists and they are not used in calculations. However, they do remain in the database.

If there are multiple observations of the same name which also have an equivalent classification (that is, normal and backsight are equivalent), then the best is the one that is found first in the database.

* Within a single station setup, a Mean Turned Angle observation is better than all the other classes - it is treated as an equivalent classification to the other classifications that are listed only when the observations appear in different station setups.

Example

If a point named "1000" is entered as the start point when calculating a from-a-baseline offset, the General Survey software searches for the first occurrence of point "1000". It then searches the rest of the database for any point named "1000", under the following rules:

- If no other point of this name is found, it uses the one it has to calculate the offset.
- If another point "1000" is found, the software compares the classes of the two points. It uses the point "1000" that has the highest classification. Remember that a Coordinate class point (for example, keyed-in) is higher than an Observation class point.

For example, if both points were keyed in, one was given a normal classification and the other a control classification, General Survey uses the control class point to calculate the offset, regardless of which record the search finds first. If one point was keyed in and one was observed, General Survey uses the keyed-in point.

- If the points are of the same class, General Survey uses the first one. For example, if both points named "1000" were keyed in, and both were given a normal classification, the first one is used.

Exceptions to the search rules

Normal search rules are not used in the following situations:

Exceptions to the search rules for GPS surveys

- **In a GPS calibration**

Calibration searches for the highest class point stored as grid coordinates. This grid point is used as one of a pair of calibration points. The General Survey software then searches for the highest class GPS point stored as WGS84 coordinates or as a WGS84 vector. This point is used as the GPS part of the point pair.

- **When starting an RTK rover**

When you start a rover survey, if the broadcast base point is called, for example, "BASE001", choosing *Start survey* causes the General Survey software to search for the highest class GPS (WGS-84) point of that name. If no GPS point with the name "BASE001" exists, but "BASE001" exists with grid or local coordinates, the General Survey software converts the grid or local coordinates of the point into a GPS (WGS-84) point. It uses the projection, datum transformation, and current calibration to calculate the point. It is then stored, as "BASE001", with WGS-84 coordinates and is given a check class classification so that the original grid or local coordinates will still be used in calculations.

Note - *The WGS-84 coordinates of the base point in the General Survey database are the coordinates from which GPS vectors are solved.*

If there is no base point in the database, the position broadcast by the base receiver is stored as a normal class point and it is used as the base coordinates.

Exceptions to the search rules for conventional surveys

- **F1 or F2 from one station setup and an MTA from another station setup**

If you observe a point on more than one face, an F1 observation and an F2 observation are combined to create an MTA record. In this situation, the MTA is used to coordinate the point. However, if there is an observation to a point on F1 or F2 only, from an earlier station setup, and later a station setup (that could be at the same station as the first) to that same point creates a new MTA, then the MTA is deemed to be of the same class as the earlier F1 or F2 observation. In this situation, the order in the database rule is invoked, and the first point in the database is deemed the best point.

- **Observations that coordinate a point are better than those that do not**

An angles and distance observation that coordinates the point, is better than an angles-only observation that does not coordinate a point. This rule applies even when the angles-only observation is earlier in the database, and is of a higher class, for example, an MTA.

Linked files and their search rules

Comma Delimited (*.csv or *.txt) files or General Survey (job) files can be linked to the current General Survey job to access external data. For more information, see [Linked files](#).

The General Survey search rules do not operate across linked files. Points in the current job are **always** used in preference to a point of the same name in the linked file, regardless of the classification. For example, if point 1000 in the current job has an As-staked classification, and point 1000 in a linked job file has a Normal coordinate classification, then the search rules will select the As-staked class point in preference to the Normal class point. If both points were in the current job, then the search rules would select the Normal class point.

Note - You can add points to the stakeout list using the *Select from file* option even if the point in the linked file already exists in the current job. When a point of the same name exists in the current job, this is the only way that you can stake a point from a linked file.

When points of the same name exist in a single CSV file, the General Survey software uses the first point.

When points of the same name exist in multiple CSV files, the General Survey software uses the point in the first CSV file. The first CSV file is the first one in the file selection list. To change the order of the CSV files, tap the tabs at the top of the file selection screen. If you change the order of the CSV files, this may change the order in which files are selected.

When you accept a CSV file selection, and you then go back and select more CSV files, all subsequent files are appended to the initial selection, using the rules. This assumes that the original selection is not altered.

Trimble recommends that you do not use multiple CSV files that contain points of the same name.

Finding the best point in the database

To find the point with the highest classification, use the *Point manager*. In the *Point manager*, the highest class point always appears at the first level in the tree structure. If there is more than one point of the same name, the tree structure has a second level, which contains all points of the same name. The point with the highest classification appears at the top, followed by the other points of the same name, in the order in which they were observed.

Duplicate points and overwriting

Duplicate point tolerances compare the coordinates of a point to be stored with a point of the same name that already exists in the database. If the coordinates are outside the duplicate point tolerances defined in the survey style, the *Duplicate point out of tolerance* dialog appears. Select *Overwrite* to store the new point and delete all existing points of the same class or below.

Of the options displayed, *Overwrite* and *Average* are the only two options that might result in a point being 'promoted' - thus changing the coordinates for the best point.

Note - This warning only appears if the new point is out of tolerance with the original point. If you have changed the tolerance values, the message may not appear. For more information, see [Duplicate point tolerance](#).

In a conventional survey, observations from one station setup to the same point are combined to create an MTA record. You do not see the "duplicate point out of tolerance" warning.

If you store a face 2 observation to a point that already has a face 1 observation, the face 2 observation is checked to see if it is within tolerance of the face 1 observation and then stored. For more information about face 1 and face 2 observations, see [Measuring a point in two faces](#).

WARNING - The duplicate point warning could indicate that you are about to overwrite a point that has dependent vectors. If you continue, the coordinates of the dependent vectors could change.

The overwrite rules

Overwrite deletes points, and results in a change to the coordinates of the best point.

Note - Deleted points remain in the database and have a search class of Deleted. For more information, see [Search class](#).

If the *Overwrite* option does not appear in the General Survey software, this means that an overwrite would not result in changes to the coordinates of the best point.

General observation and coordinate overwrite rules

- Observations can overwrite and therefore delete Observations.
- Coordinates can overwrite and therefore delete Coordinates.
- Observations cannot overwrite Coordinates.
- Coordinates cannot overwrite Observations.

One exception to these rules is when a Rotate, Scale or Translation is performed. When one of these transformations is applied, the original observations are deleted and replaced by the translated points.

That does not mean that all Observations can overwrite all other Observations of the same name, and all Coordinates can overwrite all Coordinates of the same name. The [Search class](#) rules still apply.

Some examples

- If you measure a point with a name that already exists in the database, you can choose to overwrite it when you store the new one. All previous Observations of the same name, and with the same or a lower search class, are deleted.
If a point stored as a Coordinate existed, then overwrite would not have been an option, because overwriting the observations would not have changed the best point.
- If you key in a point with a name that already exists in the database, you can choose to overwrite it when you store the new one. All previous points stored as Coordinates, of the same name, and with the same or a lower search class, are deleted. Points of the same name stored as Observations are not affected.

Storing another does not change the best point

If you measure or key in a point with a name that already exists in the database, you can choose to store both points in the database, and both are transferred with the job. The General Survey

search rules ensure that the point with the highest class is used for calculations. If there are two points of the same class, the **first** is used.

Averaging overwrites another average

If you measure a point and use a name that already exists in the current job, you can choose to average all points of that name. To store the observation and an averaged grid coordinate, select *Average*. Where an averaged position of that name already exists, the new averaged position will overwrite the existing averaged position. Averaged points have a coordinate classification. Coordinates have a higher classification than observations, so the stored averaged position is used in preference to any observations. You can also choose to Auto-average when the point is within tolerance. For more information, see [Averaging methods](#).

Assigning control class to a point

Control class is the highest classification that you can give to a point. Any high-accuracy point that you use as a fixed standard in a job can be a control point.

If you specify control search class when you key in the coordinates for a point, you can be sure that those coordinates will not change until you key in another point of the same name and the same search class (control) and choose to overwrite the first point.

The General Survey software never elevates measured points to control class. This is because measured points have measurement errors and may change or be measured again during the course of the job. If the keyed-in point "CONTROL29" is control class, generally you would not want the coordinates of that point to change. A control class point is held fixed for the job.

The General Survey software can measure **observed** control points, but it does not give them control classification. This is because, in calibration, the measured point often has the same name as the keyed-in control point. This makes it easier to set up the calibration. It also makes it easier to manage your data, for example, if you know that all references to point "CONTROL29" on the ground are also references to point "CONTROL29" in the database.

Calculations performed by the General Survey software

This appendix outlines some of the calculations performed by the General Survey software.

- [Transformations applied to GNSS positions](#)
- [Ellipsoid calculations](#)
- [Conventional instrument calculations](#)
- [Area calculations](#)

Transformations applied to GNSS positions

For RTK surveying, coordinate transformations are required so that one set of coordinates (GNSS positions) can be represented in terms of another (grid positions), and vice versa.

Tip - To see an example of converting measurements to grid coordinates using the General Survey software, click [here](#) and then select the *Calibration* section.

This section provides an overview of the management and application of coordinate transformations using the General Survey software. It describes how to apply a datum transformation and map projection, and horizontal and vertical adjustments.

With the General Survey software, the site calibration process defines transformation parameters derived from a set of points. This set of points is coordinated in terms of two systems:

- WGS-84 Latitude, Longitude, Height (LLH) geodetic coordinates
- A local system with project-specific Northing, Easting, Elevation (NEE) grid coordinates

The following diagram shows the order of calculations performed when a calibration is calculated.

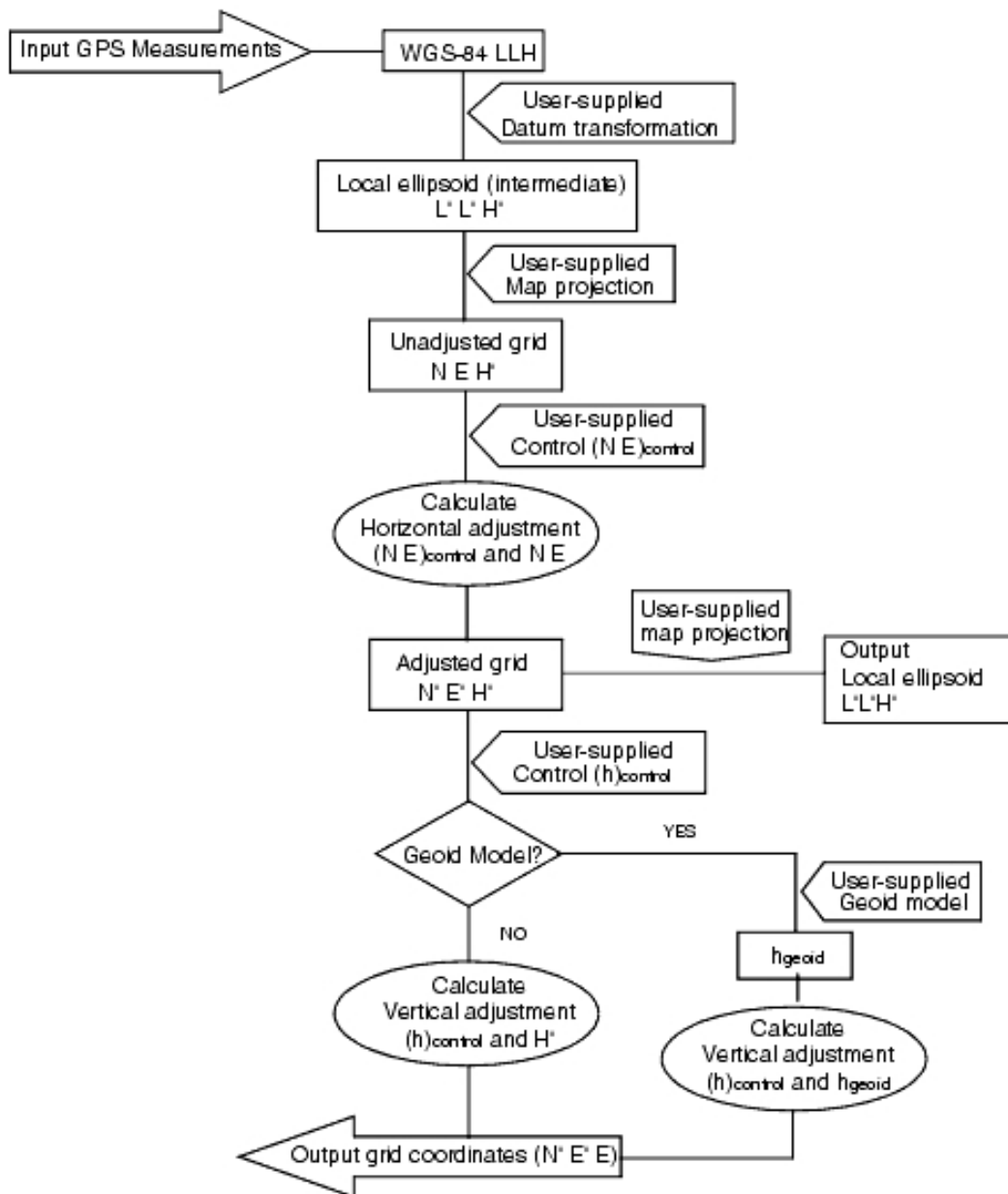

The formulae used in the above flow diagram are detailed below.

Transforming WGS-84 ECEF to WGS-84 LLH

When GNSS signals are processed by a receiver, they yield Earth-Centered-Earth-Fixed (X, Y, Z) coordinates, which must then be transformed to more meaningful geodetic coordinates (ϕ , λ , H). Here, ϕ represents the geodetic latitude, λ is the longitude, and H is the perpendicular height above the WGS-84 ellipsoid.

First we define:

$$e^2 = 2\phi - \phi^2$$

$$N = \frac{r}{\sqrt{1 - e^2 \sin^2(\phi)}}$$

where ϕ is the flattening value for the source ellipse and r is the semi-major axis.

The values of the ECEF coordinates are:

- $X = (N + H) \cdot \cos(\phi) \cdot \cos(\lambda)$
- $Y = (N + H) \cdot \cos(\phi) \cdot \sin(\lambda)$
- $Z = [N(1 - e^2) + H] \cdot \sin(\phi)$

The inverse problem (that of transforming ECEF coordinates to ϕ , λ , and H) is solved by using an iterative procedure. The values of e^2 and N now use the destination ellipsoid flattening and semi-major axis values:

$$\varphi = \tan^{-1} \left(\frac{Z}{\sqrt{X^2 + Y^2}} (1 - e^2) \right)$$

then iterate

$$\varphi = \tan^{-1} \left(\frac{Z + e^2 N \sin(\varphi)}{\sqrt{X^2 + Y^2}} \right)$$

$$\lambda = \tan^{-1} \left(\frac{Y}{X} \right)$$

if $45^\circ\text{S} < \phi < 45^\circ\text{N}$

$$H = \frac{\sqrt{X^2 - Y^2}}{\cos(\varphi)} - N$$

or if $\phi > 45^\circ\text{N}$ or $\phi < 45^\circ\text{S}$

$$H = \frac{Z}{\sin(\varphi)} - N(1 + e^2)$$

Datum transformation

A datum transformation provides the necessary parameters for converting from one geodetic coordinate system to another.

The General Survey software can apply a predefined three- or seven-parameter datum transformation. It can also calculate a three-parameter datum transformation given points coordinated in WGS-84 and local L'L'H'.

$$X = T + kRX'$$

where X' is a matrix of 3-D Cartesian ECEF coordinates or Cartesian local coordinates, T is a matrix of translation parameters, k is a scalar, and R is a rotation matrix. In most cases, X' is measured and T , k , and R are user-specified.

To calculate a three-parameter datum transformation, pairs of WGS-84 LLH and local L'L'H' coordinates are needed.

In the trivial one point case, the three translation parameters are just the vector components of the ECEF vector that connect the ECEF pair derived from the WGS-84 LLH and the local L'L'H'.

In the non-trivial case, the translation parameters are the vector components of the average vector. This is represented as:

$$AX + W = 0$$

where the solution

$$X = \begin{bmatrix} \Delta X \\ \Delta Y \\ \Delta Z \end{bmatrix}$$

and

$$W = \begin{bmatrix} X_1 - X'_1 \\ Y_1 - Y'_1 \\ Z_1 - Z'_1 \\ X_2 - X'_2 \\ Y_2 - Y'_2 \\ Z_2 - Z'_2 \\ \vdots \end{bmatrix}$$

where X_n is the value of the ECEF coordinate derived from the local L'L'H' of the nth 3-D point in the list, and X'_n is the X value of the ECEF coordinate derived from the WGS-84 LLH of the nth 3-D point and

$$A = \begin{bmatrix} 1 & 0 & 0 \\ 0 & 1 & 0 \\ 0 & 0 & 1 \\ 1 & 0 & 0 \\ 0 & 1 & 0 \\ 0 & 0 & 1 \\ \vdots \end{bmatrix}$$

is called the Molodensky matrix.

For more information, refer to *GPS Satellite Surveying* by A. Leick (John Wiley & Sons, 1995).

Map projection

A map projection defines the relationship between the local ellipsoidal surface (L'L'H') and a plane. Generally, map projection parameters are based on a local conformal mapping model.

For more information about map projections, please refer to the *Map Projections--A Working Manual* by J.P. Snyder (U.S. Geological Survey Professional Paper 1295, U.S. Government Printing Office, Washington, 1987).

For nearly all projection types used in the General Survey software, the height component of a projected coordinate is just the height above or below the datum at that point. For a plane projection, however, the definition includes an ellipsoidal height and a projected surface elevation at the origin point.

Horizontal adjustment

It may be necessary to minimize the discrepancy between local fixed control coordinates (NEcontrol) and projected grid coordinates (N'E'). The horizontal adjustment solves parameter translations in north and east (ΔN , ΔE), a rotation ϕ , and a scale factor k using two different sets of plane coordinates—one converted from measurements in the field, and the other from a control list. Where the General Survey software generates its own three-parameter datum transformation, it is necessary to provide for scaling and rotation. This is done by a horizontal adjustment.

The following diagram shows the transformation between two coordinate systems.

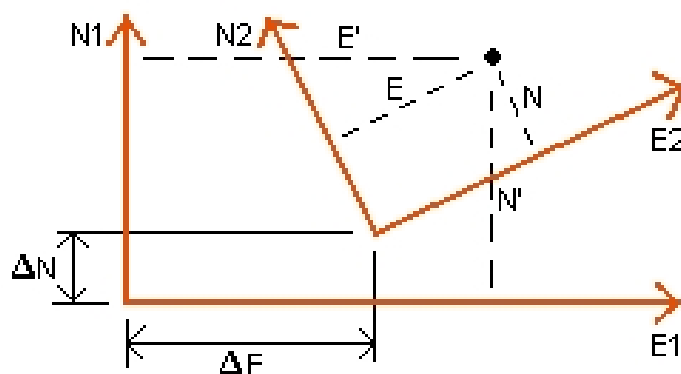

Coordinate systems for a horizontal adjustment

The General Survey software minimizes the discrepancy between local NE control and NE values derived using GNSS observations and a datum transformation and map projection. It does this by performing a plane horizontal least-squares adjustment with no weighting.

In the trivial one point case, the translation parameters are just the Northing and Easting components of the vector between the two coordinated values. The scale factor is one, and the rotation value is zero.

For two or more points, calculation of horizontal adjustment uses a simple four-parameter transformation. This solves for two translations (ΔN , ΔE), a rotation (ϕ), and a scale factor (k) between coordinate pairs.

The geometry between the two coordinate systems results in two transformation equations:

- $N' = aN + bE + \Delta N$
- $E' = -bN + aE + \Delta E$

where $a = k \cos \phi$ and $b = k \sin \phi$ are used to simplify the matrix representation, and ΔN and ΔE represent the shifts of the N and E axis in the N' and E' system.

Common points in both coordinate systems are used in a least-squares adjustment to solve the four unknown parameters (a , b , ΔE , and ΔN).

Once estimates of a and b are determined, the rotation and scale between the two systems is calculated by:

$$\varphi = \tan^{-1}\left(\frac{a}{b}\right) \text{ and } k = \sqrt{a^2 + b^2}$$

For more information about horizontal adjustment, please refer to *Observations and Least Squares* by E. Mikhail (John Wiley & Sons, 1982).

Vertical adjustment

The General Survey software determines a vertical adjustment using least-squares with no weighting. This adjustment requires measured WGS-84 heights and control elevations.

In the trivial one-point case, the adjustment consists of a constant height shift only. For two or more points, a tilt in north and east are also computed.

The inclined plane parameters are determined by solving the matrix equation:

$$AX = B$$

where the solution

$$X = \begin{bmatrix} \Delta H \\ \Delta E \\ \Delta N \end{bmatrix}$$

the components being the constant height shift and tilt east and north (in terms of a height shift per unit distance east or north), and the design matrix

$$A = \begin{bmatrix} 1 & E_1 - E_1 & N_1 - N_1 \\ 1 & E_2 - E_1 & N_2 - N_1 \\ & \vdots & \\ 1 & E_n - E_1 & N_n - N_1 \end{bmatrix}$$

where E_n N_n are the coordinates of the n th point as derived from the WGS-84 data set.

E_1 N_1 are the coordinates of the origin point of the adjustment. (The origin point can be any one of the n points.)

$$B = \begin{bmatrix} H'_1 - H_1 \\ H'_2 - H_2 \\ \vdots \\ H'_n - H_n \end{bmatrix}$$

where $H'_n - H_n$ is the difference in elevation between the keyed in value for the n th point and the value derived from the WGS-84 data set.

Ground scale factor

In the General Survey software, you can define a *Project height* when you create a *No projection/no datum* job. The project height is used after you perform a site calibration to compute a scale factor for the projection, so that ground coordinates are computed at elevation.

The projection scale factor is calculated as follows:

$$SF = \frac{R + h}{R}$$

and

$$R = \frac{a}{\sqrt{1 - e^2 \sin^2(\varphi)}}$$

where:

SF	scale factor of projection
R	ellipsoidal radius
h	average elevation (reference elevation)
a	semi major axis
e ²	eccentricity ²
φ	origin latitude of projection

Geoid model

The General Survey software can use a geoid model to provide orthometric heights from measured (by GNSS) WGS-84 heights.

Geoid model is one of the options in the *Vertical adjustment* field. (The other options in this field are *No adjustment*, *Inclined plane*, *Geoid model/Inclined plane*).

If you select Geoid model and you do not perform an in-field calibration, the elevation values displayed by the General Survey software represent the unadjusted elevation above the defined geoid using the relationship:

$$h_{\text{geoid}} = H - N$$

where:

h _{geoid}	the unadjusted elevation above the geoid
H	the measured GNSS height above the ellipsoid
N	the geoid ellipsoidal separation, derived from a geoid model

If you select *Geoid model* and then perform an in-field calibration, the General Survey software computes the calibration parameters using h_{control} and h_{geoid} as inputs, so that the geoid model is inclined to fit the local control elevations. The method of vertical adjustment becomes *Geoid/Inclined plane*.

Ellipsoid calculations

The ground and ellipsoid distances in the General Survey software are calculated parallel to the ellipsoid. The equations used for these calculations are based on the Robbins ellipsoid geometry formulas. These formulas (by Dr A.R. Robbins) are in the *Empire Survey Review* No. 125, 1962. They

are accurate to better than 20 mm over distances of 1,500 km. The errors can reach 16 meters at 4,500 km and more than 2,000 meters at 9,000 km.

Conventional instrument calculations

The following diagram labels the observations and corrections that are applied when you use the General Survey software with a conventional instrument.

Note - Interim corrections are not shown in the diagram. They are enclosed in square brackets in the table that follows.

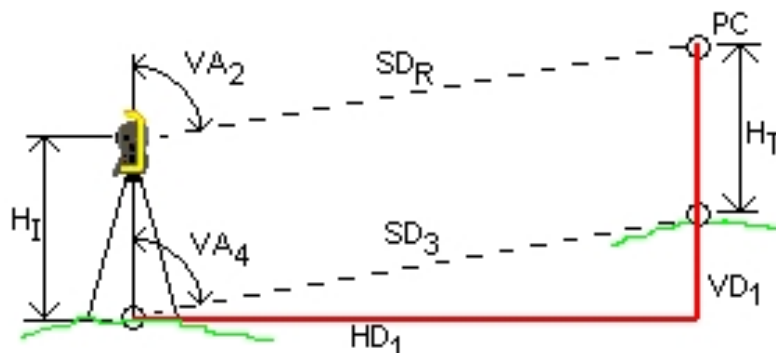

Correction variables used in conventional instrument calculations

Where:

VA2	Vertical angle from conventional instrument. The General Survey software assumes that the conventional instrument applies any corrections for collimation and tilt.
[VA3]	Vertical angle corrected for curvature and refraction
VA4	Vertical angle corrected for curvature and refraction, instrument and target heights
SDR	Slope distance from EDM
[SD1]	Slope distance corrected for prism constant (PC)
[SD2]	Slope distance corrected for prism constant and PPM
SD3	Slope distance corrected for prism constant, PPM, instrument and target heights
HD1	Horizontal distance between instrument point and target point
VD1	Vertical distance between instrument point and target point
HI	Height of instrument
HT	Height of target
PC	Prism constant

Prism constant correction

The prism constant is applied to all slope distances. It is usually negative, but can be positive.

$$SD_1 = SD_R + PC$$

where:

SDR	measured (raw) slope distance
SD1	resultant slope distance
PC	prism constant

PPM correction

The parts per million (PPM) correction is applied to the slope distance after being corrected for the prism constant (see above). PPM depends on pressure and temperature.

$$D_2(P, T) = SD_1 \left[J - \frac{N - P}{273.16 + T} \right] \cdot 10^{-6}$$

where:

P	air pressure in millibars
T	temperature in °C
J & N	constants <i>supplied by the EDM manufacturer</i>

The following table lists some manufacturers of conventional instruments, and the J (RefractiveIndex) and N (CarrierWavelength) constants that the General Survey software uses to compute the PPM correction for those instruments.

Manufacturer of conventional instruments	J constant	N constant
Trimble VX/S/M Series	from instrument	from instrument
Trimble 5600	274.41	79.39
Trimble 3300/3600	278.77	80.653
Trimble TTS300/500	270.0	79.167
Sokkia SET	279.0	79.400
Topcon	279.7	79.600
Geotronics 400/600	275.0	79.550
Leica	282.0	79.400
Zeiss Elta2/Elta3/Elta4	255.0	79.100
Zeiss Elta C	281.8	79.391
Pentax	279.0	79.400
Nikon	275.0	79.5065

Note - The Trimble VX/S/M Series instrument J and N constants that are read from the instrument can be viewed in an exported JobXML file.

Note - The *J* constant value is the refractive index of the instrument. The *N* constant value is for use with pressure measurements in millibars. In the .dc file, the value is converted to one that can be used with pressure measurements in mmHg.

Curvature and refraction correction

The curvature and refraction correction is applied to vertical angles according to the coefficient of refraction that you set.

$$VA_3 = VA_2 - \left[\frac{(COnOff - k \times ROnOff) \times SD_1}{2R} \right] \times \frac{180}{\pi}$$

where:

COnOff if the *Curvature correction* option is selected, this value is 1; otherwise it is 0

ROnOff if the *Refraction correction* option is selected, this value is 1; otherwise it is 0

k coefficient of terrestrial refraction, specified in the *Refraction const.* field on the *Corrections* screen

R approximate spheroid radius = 6378137m. (WGS-84 semi-major axis)

SD1 slope distance, from equation - [Prism constant correction](#)

VA2 vertical angle, from instrument

VA3 corrected vertical angle

Instrument and target height reduction

The corrected vertical angle (VA4) from the instrument to the target is:

$$VA_4 = \tan^{-1} \left[\frac{SD_2 \sin VA_3}{SD_2 \cos VA_3 + H_I - H_T} \right]$$

where:

H I instrument height

H T target height

SD2 slope distance

VA3 vertical angle, from equation - [Curvature and refraction correction](#)

VA4 corrected vertical angle

The slope distance from source point to target point (SD3) is given by the following:

$$SD_3 = \frac{SD_2 \sin VA_3}{\sin VA_4}$$

Face 1/Face 2 determination

This section describes how the General Survey software reduces Face 2 readings to Face 1 readings in order to perform calculations. It does this automatically.

The observed raw vertical angle is used to determine whether an observation is Face 1 or Face 2:

- If the vertical angle is not present the observation is assumed to be Face 1.
- If the vertical angle is in the range 0° to 180°, the observation is Face 1.
- If the vertical angle is in the range 180°-360°, the observation is Face 2.

Orientation correction

To orient circle readings so that they become azimuths, an orientation correction is applied. The orientation correction is the difference between the backsight circle reading and the backsight azimuth. This term is applied to all the other observations (circle readings) at a station.

The formula is:

$$Az_x = HA_x + (Az_B - HA_B) \text{ (Orientation correction)}$$

where:

Az _x	azimuth to any point X
HA _x	horizontal observation to any point X
Az _B	actual backsight azimuth ('reference azimuth')
HA _B	observed backsight circle reading

Slope reduction

The horizontal and vertical components of an observation (HD₁ and VD₁) are found from the vertical angle and slope distances by:

$$HD_1 = SD_3 \sin VA_4$$

$$VD_1 = SD_3 \cos VA_4$$

where:

HD ₁	horizontal distance
VD ₁	vertical distance
VA ₄	zenith angle
SD ₃	slope distance

Coordinate calculation

Coordinates of a target point are calculated from observations and the coordinates of the instrument point using:

$$N_2 = N_1 + HD_1 \cos Az_1$$

$$E_2 = E_1 + HD_1 \sin Az_1$$

$$Z_2 = Z_1 + VD_1$$

where:

N1, E1, Z1	Northing, Easting, Elevation of instrument point
N2, E 2, Z2	Northing, Easting, Elevation of target point
HD1	horizontal distance
VD1	vertical distance
Az1	from equation - Orientation correction .

Mean turned angle calculations

When the software calculates the mean turned angle and the mean distance for a point, it also calculates standard errors as follows:

For the angles, the standard error of the mean of a set of measurements formula is used:

$$\sigma = \sqrt{\frac{\sum v^2}{n(n-1)}}$$

For distances, the standard error of the set of measurements formula is used:

$$\sigma = \sqrt{\frac{\sum v^2}{(n-1)}}$$

Resection calculation

The resection calculation is a least-squares calculation that uses all available data.

Observations to the same point taken on different faces are treated as separate observations. However, the results are the same as those gained from using meaned (averaged) observations.

The residuals are given for each *point*, not each observation.

The formula used for the standard errors is as follows:

$$\sigma = \frac{(\sqrt{\sum v^2})}{(n-1)}$$

Traverse calculation

This section shows the formulae that the software uses when it calculates a traverse.

Compass adjustment

The Compass adjustment distributes the error in proportion to the length of the traverse lines. The formulae are as follows:

$$\text{Northing adjustment} = \frac{D}{\sum D} \times \text{Northing misclosure}$$

where:

D horizontal distance
 ΣD sum of the horizontal distances in the traverse

$$\text{Easting adjustment} = \frac{D}{\Sigma D} \times \text{Easting misclosure}$$

where:

D horizontal distance
 ΣD sum of the horizontal distances in the traverse

Transit adjustment

The Transit adjustment distributes the error in proportion to the northing and easting of each traverse point.

$$\text{Northing adjustment} = \frac{\Delta N}{\Sigma \Delta N} \times \text{Northing misclosure}$$

where:

ΔN change in northing for the traverse line
 $\Sigma \Delta N$ sum of the changes in northings of all the traverse lines

$$\text{Easting adjustment} = \frac{\Delta E}{\Sigma \Delta E} \times \text{Easting misclosure}$$

where:

ΔE change in easting for the traverse line
 $\Sigma \Delta E$ sum of the changes in eastings of all the traverse lines

Angular adjustments

There are three options for distributing the angular error in a traverse:

- Proportional to distance-the error is distributed among the angles based on the sum of the inverses of the forward and back traverse distances for each point. The formula used is as follows:

$$A_a = \frac{\frac{1}{\text{to dist}} + \frac{1}{\text{from dist}}}{\Sigma \left(\frac{1}{\text{to dist}} + \frac{1}{\text{from dist}} \right)} \times A_m$$

where:

A_a Angular adjustment
 A_m Angular misclose

- Equal proportions--the error is distributed evenly among the angles in the traverse.
- None--the error is not distributed.

Elevation adjustments

There are three options for distributing the elevation error in a traverse:

- Proportional to distance--the error is distributed in proportion to the length of the traverse line to the point.
- Equal proportions--the error is distributed evenly among the traverse lines.
- None--the error is not distributed.

Standard errors recorded with conventional observations

Each conventional observation that is recorded in the job file has standard errors associated with it. The standard errors that are recorded with the observations are determined as follows:

- For a single observation to a point (for example, Measure topo) the standard error values assigned to the observation are the instrument standard error values (a-priori values). This is because there is nothing else that the standard errors can be determined from.
If a distance fails to reach the instrument's rated accuracy (typically due to an unstable target), General Survey saves the achieved standard deviation of the measurement. When this occurs, a message tells you that the instrument's distance standard deviation was not achieved for this observation.
- Computed 'observations' for example, Dual prism offsets, Distance offsets, Circular Object and Remote Object measurement methods, the standard errors are recorded as null.

Area calculations

Grid areas

When the *Distances* field is set to Grid, the area computed is the area at sea level and is calculated using grid coordinates. Elevations are not used in the computation.

Ellipsoid areas

When the *Distances* field is set to Ellipsoid, the ground area is computed by multiplying the grid area by the projection scale factor (at the centroid of the area) squared.

Ground areas

When the *Distances* field is set to Ground, the ground area is computed by multiplying the grid area by the combined scale factor (at the centroid of the area) squared.

The combined scale factor (at the centroid of the area) is the point scale factor multiplied by the sea level factor,

where, the point scale factor is computed for the centroid of the area based on the current projection definition, and the sea level factor is:

$$\left(\frac{\bar{h} + R}{R} \right)$$

So the ground area is:

$$GA \times \left(PSF \times \left(\frac{\bar{h} + R}{R} \right) \right)^2$$

where:

$$\bar{h} = \frac{\sum h_i}{N}$$

GA	Grid area
PSF	Point scale factor
N	number of elements with elevations
\bar{h}	average elevation
R	ellipsoidal radius

Glossary

This topic explains some of the terms used in this Help.

almanac	Data, transmitted by a GNSS satellite, that includes orbit information on all the satellites, clock correction, and atmospheric delay parameters. The almanac facilitates rapid SV acquisition. The orbit information is a subset of the ephemeris data with reduced precision.
Angles and distance	Measurement of horizontal and vertical angles and a slope distance.
Angles only	Measurement of horizontal and vertical angles.
Anti-Spoofing (AS)	A feature that allows the U.S. Department of Defense to transmit an encrypted Y-code in place of P-code. Y-code is intended to be useful only to authorized (primarily military) users. Anti-Spoofing is used with Selective Availability to deny the full precision of GNSS to civilian users.
Autolock	The ability to lock onto and track a target.
automated rounds	The process of automatically measuring a multiple observations to observed points.
autonomous positioning	The least precise form of positioning that a GNSS receiver can produce. The position fix is calculated by one receiver from satellite data alone.
azimuth	Horizontal direction relative to a defined coordinate system.
Backsight	Point with known coordinates or known azimuth from the instrument point that is used to orientate the instrument during station setup.
base station	In a GNSS survey, you observe and compute baselines (the position of one receiver relative to another). The base station acts as the position from which all unknown positions are derived. A base station is an antenna and receiver set up on a known location specifically to collect data to be used in differentially correcting rover files.
baud	A unit of data transfer speed (from one binary digital device to another) used in describing serial communications; generally one bit per second.
C/A (Coarse Acquisition) code	A pseudorandom noise (PRN) code modulated onto an L1 signal. This code helps the receiver compute the distance from the satellite.
change face	Turn a servo instrument from the face 1 observing face to face 2.
CMR	Compact Measurement Record. A satellite measurement message that is broadcast by the base receiver and used by RTK surveys to calculate an accurate baseline vector from the base to the rover.
constellation	A specific set of satellites used in calculating positions: three satellites for 2D fixes,

	four satellites for 3D fixes. All satellites visible to a GNSS receiver at one time. The optimum constellation is the constellation with the lowest PDOP. See also PDOP .
construction offsets	A specified horizontal and/or vertical offset distance to enable equipment to operate without disturbing construction stakes.
Construction point	A point that is measured using the "quick fix" option in COGO.
conventional survey	In a conventional survey, the controller is connected to a conventional survey instrument such as a total station.
curvature and refraction	Correction to the measured vertical angle for the curvature of the earth and the refraction caused by the earth's atmosphere.
data message	A message, included in the GNSS signal, that reports on the location and health of the satellites as well as any clock correction. It includes information about the health of other satellites as well as their approximate position.
datum	See geodetic datum.
design code	The code name given to the design point.
design name	The name given to the design point.
Differential Positioning	Precise measurement of the relative position of two receivers tracking the same satellites simultaneously.
Direct Reflex (DR)	Type of EDM that can measure to non reflective targets.
DOP (Dilution of Precision)	An indicator of the quality of a GNSS position. DOP takes into account the location of each satellite relative to other satellites in the constellation, as well as their geometry relative to the GNSS receiver. A low DOP value indicates a higher probability of accuracy. Standard DOPs for GNSS applications are: <ul style="list-style-type: none"> - PDOP - Position (three coordinates) - GDOP - Geometric (three coordinates and time) - RDOP - Relative (Position, averaged over time) - HDOP - Horizontal (two horizontal coordinates) - VDOP - Vertical (height only) - TDOP - Time (clock offset only)
Doppler shift	The apparent change in frequency of a signal caused by the relative motion of satellites and the receiver.
DTM	Digital Terrain Model. An electronic representation of terrain in three dimensions.
dual-frequency	GNSS receiver that uses both L1 and L2 signals from GNSS satellites. A dual-frequency receiver can compute more precise position fixes over longer distances and under more adverse conditions because it compensates for ionospheric delays.
Dual-prism offset	Measurement of horizontal and vertical angles and a slope distance to two prisms located on one prism pole for the purpose of positioning an obstructed point.

Earth-Centered-Earth-Fixed (ECEF)	A cartesian coordinate system used by the WGS-84 reference frame. In this coordinate system, the center of the system is at the earth's center of mass. The z axis is coincident with the mean rotational axis of the earth and the x axis passes through 0° N and 0° E. The y axis is perpendicular to the plane of the x and z axes.
eccentric object	Measurement of horizontal and vertical angles and a slope distance to the face of a radial object (for example, power pole). An additional horizontal angle is observed to the side of the object to calculate the radius and thus position the center of the object.
EGNOS	European Geostationary Navigation Overlay Service . A satellite-based augmentation system (SBAS) that provides a free-to-air differential correction service for GNSS.
elevation	Height above mean sea level. Vertical distance above the geoid.
elevation mask	The angle below which Trimble recommends that you do not track satellites. Normally set to 10 degrees to avoid interference from buildings and trees as well as ground multipath errors.
ellipsoid	A mathematical model of the earth formed by rotating an ellipse around its minor axis.
ephemeris	The current satellite position predictions, transmitted in the data message.
epoch	The measurement interval of a GNSS receiver. The epoch varies according to the survey type: - for real-time surveys it is set at one second - for postprocessed surveys it can be set to a rate of between one second and one minute
Face 1 (F1)	Observing position of an instrument where the vertical circle is commonly on the left hand side of the telescope.
Face 2 (F2)	Observing position of an instrument where the vertical circle is commonly on the right hand side of the telescope.
FastStatic survey	A type of GNSS survey. A FastStatic survey is a postprocessed survey using occupations of up to 20 minutes to collect raw GNSS data. The data is postprocessed to achieve sub-centimeter precisions.
feature codes	Simple descriptive words or abbreviations that describe the features of a point. For more information, refer to the Help
fixed solution	Indicates that the integer ambiguities have been resolved and a survey is initialized. This is the most precise type of solution.
float solution	Indicates that the integer ambiguities have not been resolved, and that the survey is not initialized.
FSTD (fast standard)	The method of measuring one distance and one angle to coordinate a point.
GAGAN	GPS Aided Geo Augmented Navigation. A regional satellite-based augmentation system (SBAS) currently in development in India.
Galileo	Galileo is a global navigation satellite system (GNSS) built by the European Union

	(EU) and European Space Agency (ESA). Galileo is an alternative and complementary GNSS to the U.S. Global Positioning System (GPS), the Russian GLONASS, and the Japanese Quasi-Zenith Satellite (QZSS).
GDOP	Geometric Dilution of Precision. The relationship between errors in user position and time, and errors in satellite range. See also DOP .
GENIO	GENERIC Input Output file exported by a number of road design software packages that defines a road as a series of strings. See also String .
geodetic datum	A mathematical model designed to fit part or all of the geoid (the physical earth's surface).
geoid	The surface of gravitational equipotential that closely approximates mean sea level.
GLONASS	GLOBal NAVigation Satellite System (GLONASS) is the global navigation satellite system (GNSS) operated for the Russian government by the Russian Space Forces. GLONASS is an alternative and complementary GNSS to the U.S. Global Positioning System (GPS), the European Union Galileo positioning system, and the Japanese Quasi-Zenith Satellite (QZSS).
GNSS	Global Navigation Satellite System (GNSS). This is the standard generic term for satellite navigation systems that provide geo-spatial positioning with global coverage.
GNSS survey	In a GNSS survey, the controller is connected to a GNSS receiver.
GPS	Global Positioning System. Based on a constellation of 24 operational satellites orbiting the earth at a high altitude.
GPS time	A measure of time used by the NAVSTAR GPS system.
H. Angle offset	Measurement of vertical angle and slope distance. Horizontal angle is then measured separately, usually to an obstructed point.
H. Angle only	Measurement of horizontal angle.
HDOP	Horizontal Dilution of Precision. See also DOP .
Helmert adjustment	The Helmert adjustment provides an alternative method for computing a resection setup. The Helmert adjustment is essentially the same adjustment as that used to compute a horizontal adjustment in a GNSS calibration.
high dynamic range (HDR)	With high dynamic range turned on, multiple images are captured, each with different exposure settings, each time the camera button is pressed. During HDR processing the images are combined to produce a composite image that has better tonal range and can therefore show more detail than any of the individual images. For images captured using a: <ul style="list-style-type: none"> • V10 imaging rover, HDR processing occurs in the camera head, immediately after image capture. • total station that has Trimble VISION technology, HDR processing can be performed in the Trimble Business Center after importing the data.

horizontal circle	Graduated or digital disc from which the horizontal angle is measured
imaging rover	A mobile device containing a camera that is used to capture images. It may contain a GNSS receiver or it may connect to a GNSS receiver or attach to a prism to record its location each time images are captured.
instrument height	Height of the instrument above the instrument point.
instrument point	Point that the instrument is occupying.
integer ambiguity	The whole number of cycles in a carrier phase pseudorange between the GNSS satellite and the GNSS receiver.
integrated survey	In an integrated survey, the controller is connected to both a conventional survey instrument and a GNSS receiver at the same time. The General Survey software can quickly switch between the two instruments, within the same job.
ionosphere	The band of charged particles 80 to 120 miles above the earth's surface. The ionosphere affects the accuracy of GNSS measurements if you measure long baselines using single-frequency receivers.
K factor	The K factor is a constant defining a vertical curve in a road definition. $K = L/A$. where: L is the length of the curve A is the algebraic difference between the incoming and outgoing slopes in %
L1	The primary L-band carrier used by GNSS satellites to transmit satellite data.
L2	The secondary L-band carrier used by GNSS satellites to transmit satellite data. Block IIR-M and later GPS satellites will transmit an additional signal on L2 called L2C.
L5	The third L-band carrier used by GNSS satellites to transmit satellite data. This has been added to Block IIF and later GPS satellites.
measurement modes: Standard (STD), Fast Standard (FSTD), Tracking (TRK)	Angles are measured and averaged as one distance is measured. STD mode is indicated by an S next to the instrument icon on the status bar. One angle and one distance are measured. FSTD mode is indicated by an F next to the instrument icon on the status bar. Angles and distances are continually measured. TRK mode is indicated by a T next to the instrument icon on the status bar.
MGRS	Military Grid Reference System
MSAS	MTSAT Satellite-Based Augmentation System. A satellite-based augmentation system (SBAS) that provides a free-to-air differential correction service for GNSS over its coverage area, which is Japan.
multipath	Interference, similar to ghosting on a television screen. Multipath occurs when GNSS signals traverse different paths before arriving at the antenna.

Neighborhood Adjustment	A coordinate adjustment that is applied to conventional surveys with multiple backsights or jobs with a GNSS site calibration. During station setup plus, resection or GNSS site calibration, residuals are calculated for each observed control point. The calculated distances from each new point to the control points used in the station setup or calibration are used to determine the coordinate adjustment to be applied to the new point.
NMEA	A standard, established by the National Marine Electronics Association (NMEA), that defines electrical signals, data transmission protocol, timing, and sentence formats for communicating navigation data between marine navigation instruments.
NTRIP	Networked Transport of RTCM via Internet Protocol
OmniSTAR	A satellite-based system that broadcasts GPS correction information.
P-code	The 'precise' code transmitted by the GPS satellites. Each satellite has a unique code that is modulated onto both the L1 and L2 carrier waves.
parity	A form of error checking used in binary digital data storage and transfer. Options for parity checking include Even, Odd, or None.
PDOP	Position Dilution of Precision, a unitless figure of merit expressing the relationship between the error in user position and the error in satellite position.
PDOP mask	The highest PDOP value at which a receiver will compute positions.
photo station	A photo station is created each time a photo or set of photos is captured using an imaging rover. A photo station defines a point and includes coordinate data, image(s), and any applicable raw sensor values.
postprocess	To process satellite data on a computer after it has been collected.
postprocessed kinematic survey	A type of GNSS survey. Postprocessed kinematic surveys store raw stop-and-go and continuous observations. The data is postprocessed to achieve centimeter-level precisions.
PPM	Parts per million correction that is applied to measured slope distances to correct for the affects of the earth's atmosphere. PPM is determined using observed pressure and temperature readings together with specific instrument constants.
Prism constant	Distance offset between the center of a prism and the point being measured.
projection	Used to create flat maps that represent the surface of the earth or parts of that surface.
QZSS	Quasi-Zenith Satellite (QZSS) is a Japanese based satellite system built by the Japan Aerospace Exploration Agency (JAXA). QZSS is a complementary GNSS to the U.S. Global Positioning System (GPS), the Russian GLONASS, and the European Union Galileo positioning system. QZSS is also a satellite-based augmentation system (SBAS).
RDOP	Relative Dilution of Precision. See also DOP .

real-time differential survey	A type of GNSS survey. A real-time differential survey uses the differential corrections transmitted from a land-based receiver or from SBAS or OmniSTAR satellites to achieve sub-meter positioning at the rover.
real-time kinematic and data logging survey	A type of GNSS survey. A real-time kinematic and data logging survey records raw GNSS data during an RTK survey. The raw data can be postprocessed later, if required.
real-time kinematic and infill survey	A type of GNSS survey. A real-time kinematic and infill survey allows you to continue a kinematic survey when radio contact with the base station is lost. The infill data must be postprocessed.
reference station	See base station .
refline	The process of establishing the position of an occupied point relative to a baseline by taking measurements to two known or unknown points.
resection	The process of establishing the position of an occupied point by taking measurements to two or more known points.
RMS	Root Mean Square. This is used to express the accuracy of point measurement. It is the radius of the error circle within which approximately 70% of position fixes are to be found.
RMT	Remote target
rounds	Conventional observation method of multiple observations to multiple points.
rover	Any mobile GNSS receiver and field computer collecting data in the field. The position of a roving receiver can be differentially corrected relative to a stationary base GNSS receiver.
RTCM	Radio Technical Commission for Maritime Services. This is a commission that was established to define a differential data link for the real-time differential correction of roving GNSS receivers. There are two types of RTCM differential correction messages, but all Trimble GNSS receivers use the newer Type 2 or Type 3 RTCM protocol.
RTK	Real-time kinematic, a type of GNSS survey.
SBAS	Satellite Based Augmentation System. SBAS is based on differential GNSS, but applies to wide area networks of reference stations (for example, (WAAS, EGNOS, MSAS). Corrections and additional information are broadcast using geostationary satellites.
single-frequency	A type of receiver that only uses the L1 GNSS signal. There is no compensation for ionospheric effects.
Single dist. Offset	Measurement of horizontal and vertical angles and a slope distance. Plus additional offset distances to position obstructed points.
SNR	Signal-to-Noise Ratio, a measure of the strength of a satellite signal. SNR ranges from 0 (no signal) to 99, where 99 is perfect and 0 means the satellite is not

	available. A typical good value is 40. A GNSS system typically starts using a satellite when its SNR value is higher than 25.
Station	The distance or interval along a line, arc, alignment, road, or tunnel.
Station setup	The process of defining the instrument occupation point and setting the orientation of the instrument to a backsight point or points.
String	A string is a series of 3D points joined together. Each string represents a single feature such as a curb line or the centerline of a road.
SV	Satellite Vehicle (or Space Vehicle).
target height	Height of prism above the point being measured.
TDOP	Time Dilution of Precision. See also DOP .
TOW	Time of Week in seconds, from midnight Saturday night/Sunday morning GPS time.
tracking	The process of receiving and recognizing signals from a satellite.
Tracklight	A visible light that guides the prism operator on the correct bearing.
TRK	Tracking mode. Used to measure towards moving targets.
USNG	United States National Grid
UTC	Universal Time Coordinated. A time standard based on local solar mean time at the Greenwich meridian. See also GPS time.
VBS	Virtual Base Station
VDOP	Vertical Dilution of Precision. See also DOP .
vertical circle	Graduated or digital disc from which the vertical angle is measured.
VPI	Vertical Point of Intersection
WAAS	Wide Area Augmentation System. A satellite-based augmentation system (SBAS) that improves the accuracy and availability of the basic GNSS signals over its coverage area, which includes the continental United States and outlying parts of Canada and Mexico.
Weight exponent	The Weight exponent is used in the Neighborhood adjustment calculation. When the coordinate adjustment to be applied to a new point is calculated, the calculated distances from each new point to the control points used in the station setup are weighted according to the Weight exponent.
WGS-84	World Geodetic System (1984), the mathematical ellipsoid used by GPS since January 1987. See also ellipsoid .
Y-code	An encrypted form of the information contained in the Pcode. Satellites transmit Y-code in place of Pcode when Anti-Spoofing is in effect.